

T M 5 - 3 6 1 0 - 2 8 7 - 2 4

**ORGANIZATIONAL, DIRECT
SUPPORT, AND GENERAL SUPPORT
MAINTENANCE MANUAL**

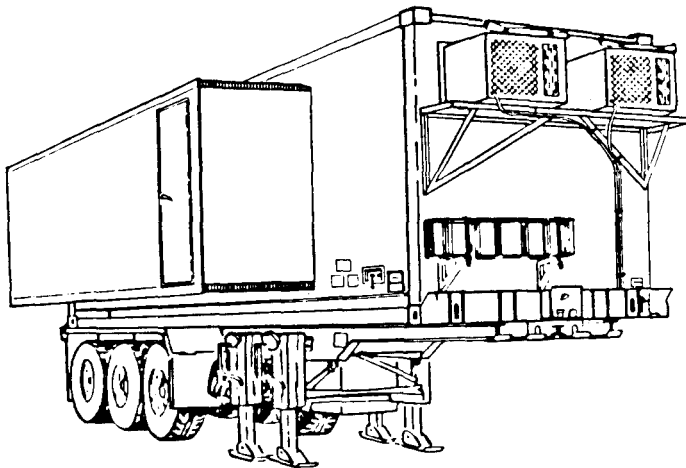

**TOPOGRAPHIC SUPPORT SYSTEM
PRESS SECTION
MODEL NO. TEAD-TSS-21
NSN 3610-01-105-1744**

**ORGANIZATIONAL
PMCS 2 - 3**

**ORGANIZATIONAL
TROUBLESHOOTING 2 - 4**

**ORGANIZATIONAL
MAINTENANCE PROCEDURES 2 - 3 3**

**DIRECT SUPPORT AND
GENERAL SUPPORT
TROUBLESHOOTING 3 - 2**

**DIRECT SUPPORT AND
GENERAL SUPPORT
MAINTENANCE PROCEDURES 3 - 2**

HEADQUARTERS, DEPARTMENT OF THE ARMY

CHANGE }
NO. 1 }

HEADQUARTERS
DEPARTMENT OF THE ARMY
WASHINGTON, D. C., 17 June 1988

Organizational, Direct Support and
General Support Maintenance Manual

TOPOGRAPHIC SUPPORT SYSTEM
PRESS SECTION
MODEL NO. TEAD-TSS-21
NSN 3610-01-105-1744

TM 5-3610-287-24, 13 June 1986, is changed as follows:

1. Remove and insert pages as indicated below. New or changed text material is indicated by a vertical bar in the margin. An illustration change is indicated by a miniature pointing hand.

Remove pages

Insert pages

B-11 and B-12

B-11 and B-12

2. Retain this sheet in front of manual for reference purposes.

By Order of the Secretary of the Army:

CARL E. VUONO
General, United States Army
Chief of Staff

Official:

R. L. DILWORTH
Brigadier General, United States Army
The Adjutant General

DISTRIBUTION:

To be distributed in accordance with DA Form, 12-25A, Unit, Direct Support and General Support Maintenance requirements for Press Section, Topographic Support System (TSS).

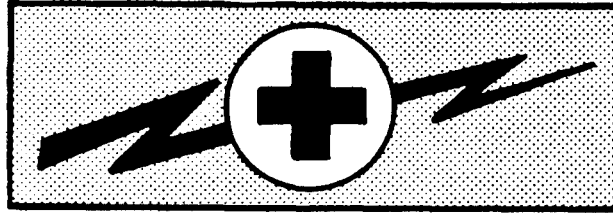

WARNING

ELECTRICAL HAZARD

- HIGH VOLTAGE. When working on high voltage components, always have an additional person present. Keep one hand away from equipment to reduce hazard of current flowing through vital organs of body. Remove all jewelry from fingers, wrists, and neck before working on electrical components. Failure to observe this warning may result in death or serious burns.
- Main power cable MUST be disconnected from Section before performing maintenance on power monitor assembly. Wiring to power monitor assembly comes directly from main power input receptacle. Failure to disconnect main power cable WILL result in death or serious injury.
- Section must be grounded properly before power is connected. Failure to do so may result in death or serious injury.
- Do not perform electrical maintenance or make electrical connections/disconnections while power cable is energized.
- Circuit breakers and power switches must be turned off before performing maintenance, service, or inspections on electrical wiring or water lines.
- FAILURE TO OBSERVE THESE WARNINGS MAY RESULT IN DEATH OR SERIOUS INJURY.

WARNING

CHEMICAL HAZARD

- Use silicone compound and adhesive in a well-ventilated area. Silicone compound and adhesive are harmful to eyes and skin. In case of contact with eyes, immediately flush eyes with water for 15 minutes, then seek medical help. In case of contact with skin, wipe off with dry cloth, then wash with soap and water.
- Use paint and thinner in a well-ventilated area. Failure to do so may result in damage to respiratory system. Wear gloves and goggles to prevent injuries to skin and eyes.

WARNING

HEAVY EQUIPMENT

- Stay clear as folding floors are raised or lowered. Weight of folding floors may cause serious personal injury.
- To avoid personal injury, use adequate number of personnel to lift or move equipment. Observe correct lifting techniques. Failure to do so may result in death or serious injury.

WARNING

Do not allow water pressure to build up in water tank during fill-up. Personal injury or damage to equipment could result.

WARNING

When moving Section, take care to avoid power lines. Serious injury or death could result from contact with power lines.

WARNING

HIGH NOISE LEVEL. Hearing protection must be worn while operating Printing Press. Failure to do so may result in hearing impairment.

For first aid procedures, refer to FM 21-11.

TECHNICAL MANUAL
NO. 5-3610-287-24

HEADQUARTERS
DEPARTMENT OF THE ARMY
WASHINGTON, D.C., 13 June 1986

Organizational, Direct Support, and
General Support Maintenance Manual
for the
TOPOGRAPHIC SUPPORT SYSTEM PRESS SECTION
Model No. TEAD-TSS-21
NSN 3610-01-105-1744

REPORTING ERRORS AND RECOMMENDING IMPROVEMENTS

You can help improve this manual. If you find any mistakes, or if you know of a way to improve the procedures, please let us know. Mail your letter, DA Form 2028 (Recommended Changes to Publications and Blank Forms), or DA Form 2028-2 located in the back of this manual directly to: Commander, U.S. Army Troop Support Command, ATTN: AMSTR-MCTS, 4300 Goodfellow Boulevard, St. Louis, MO 63120-1798. A reply will be furnished to you.

	Page
CHAPTER 1 INTRODUCTION	1-1
Section I General Information	1-1
Section II Equipment Description and Data	1-3
Section III Technical Principles of Operation	1-3
CHAPTER 2 ORGANIZATIONAL MAINTENANCE	2-1
Section I Repair Parts; Special Tools; Test, Measurement, and Diagnostic Equipment (TMDE); and Support Equipment	2-1
Section II Service Upon Receipt	2-1
Section III Organizational Preventive Maintenance Checks and Services (PMCS)	2-3
Section IV Organizational Troubleshooting	2-4
Section V Organizational Maintenance Procedures	2-33
CHAPTER 3 DIRECT SUPPORT AND GENERAL SUPPORT MAINTENANCE	3-1
Section I Repair Parts; Special Tools; Test, Measurement, and Diagnostic Equipment (TMDE); and Support Equipment	3-1
Section II Service Upon Receipt	3-1
Section III Direct Support and General Support Preventive Maintenance Checks and Services (PMCS)	3-2

	Page
Section IV	
Direct Support and General Support Troubleshooting	3-2
Section V	
Direct Support and General Support Maintenance Procedures	3-2
APPENDIX A REFERENCES	A-1
APPENDIX B MAINTENANCE ALLOCATION CHART	B-1
Section I Introduction	B-1
Section II Maintenance Allocation Chart for Topographic Support System Press Section	B-5
Section III Tool and Test Equipment Requirements for Topographic Support System Press Section	B-11
Section IV Remarks	B-13
APPENDIX C EXPENDABLE/DURABLE SUPPLIES AND MATERIALS LIST	C-1
Section I Introduction	C-1
Section II Expendable/Durable Supplies and Materials List	C-2
INDEX	Index 1

CHAPTER 1

INTRODUCTION

Section I. GENERAL INFORMATION

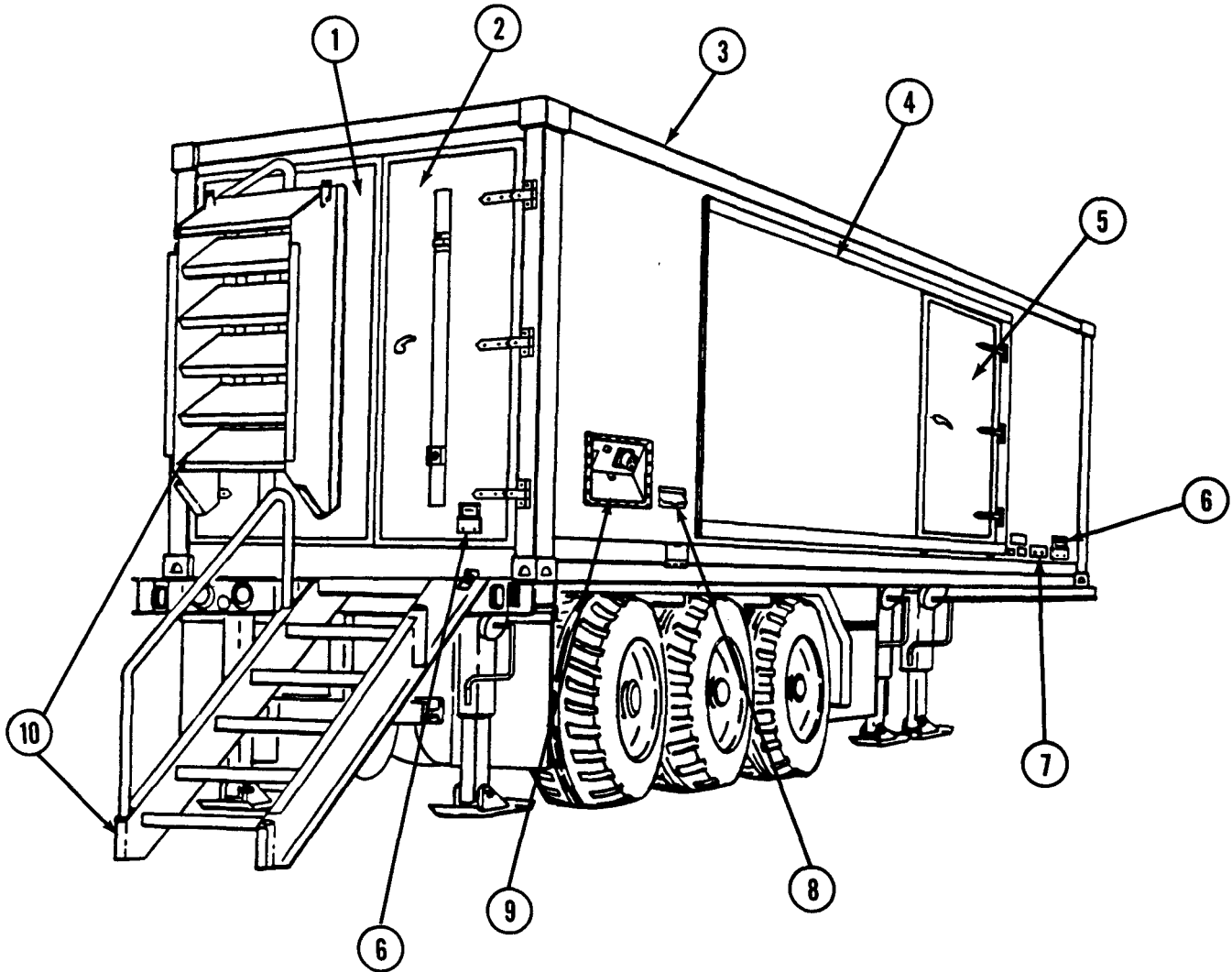

- | | |
|---------------------------|----------------------------|
| 1 Equipment Door | 6 Incliner |
| 2 Rear Personnel Door | 7 Water Box |
| 3 Section Body | 8 Telephone Entrance Panel |
| 4 Expanding Sides | 9 Power Entry Panel |
| 5 Curbside Personnel Door | 10 Boarding Ladders |

Topographic Support System Press Section Exterior

1-1. SCOPE . This manual contains organizational, direct support, and general support maintenance instructions for the Topographic Support System (TSS) Press Section, Model No. TEAD-TSS-21. Operating and operator maintenance instructions for the TSS Press Section are contained in TM 5-3610-287-10. Repair parts and special tools are listed in TM 5-3610-287-24P, Organizational, Direct Support, and General Support Maintenance Repair Parts and Special Tools List (RPSTL), Topographic Support System Press Section. Lubrication instructions are found in LO 5-3610-287-12, Lubrication Order, Topographic Support System Press Section. The location of authorized equipment is shown in paragraph 1-7 of TM 5-3610-287-10.

1-2. MAINTENANCE FORMS AND RECORDS. Department of the Army forms and procedures used for equipment maintenance will be filled out in accordance with DA PAM 738-750, The Army Maintenance Management System (TAMMS).

1-3. DESTRUCTION OF ARMY MATERIEL TO PREVENT ENEMY USE. For destruction procedures for this equipment, see TM 750-244-3, Procedures for Destruction of Equipment to Prevent Enemy Use.

1-4. PREPARATION FOR STORAGE OR SHIPMENT. For preparation for movement, refer to TM 5-3610-287-10, paragraph 2-7. For administrative storage, refer to TM 740-90-1.

1-5. OFFICIAL NOMENCLATURE LIST. The following list provides a cross-reference for item names that differ between operator maintenance and organizational, direct support, and general support maintenance.

NOMENCLATURE CROSS-REFERENCE LIST

<u>Operator</u>	<u>Organizational</u> <u>Direct Support General Support</u>
Cargo Door	Equipment Door
Handwinch and Hoist Cable	Handwinch Assembly
MAIN 60 Hz POWER Switch	Main Power Switch
120-Volt AC Outlet	Duplex Receptacle
Phase Monitor Meter	Power Monitor Assembly
Removable Floor Section Mounting Brackets	Removable Floor Section Carrier Brackets
Telephone Line Receptacle	Interior Junction Box Binding Post
12-Volt DC Input Receptacle	DC Receptacle
Water Level Indicator	Liquid Level Gage
Water Tank Temperature Gage	Remote Reading Thermometer

1-6. REPORTING EQUIPMENT IMPROVEMENT RECOMMENDATIONS (EIRs). If your Section needs improvement, let us know. Send us an EIR. You, the user, are the only one who can tell us what you do not like about your equipment. Let us know why you do not like the design or performance. Put it on an SF 368 (Quality Deficiency Report). Mail it to us at: Commander, U.S. Army Troop Support Command, ATTN: AMSTR-QX, 4300 Goodfellow Boulevard, St. Louis, MO 63120-1798. We'll send you a reply.

Section II. EQUIPMENT DESCRIPTION AND DATA

1-7. EQUIPMENT CHARACTERISTICS, CAPABILITIES, AND FEATURES. Equipment characteristics, capabilities, and features can be found in paragraph 1-6, TM 5-3610-287-10.

1-8. LOCATION AND DESCRIPTION OF MAJOR COMPONENTS. Location and description of major components can be found in paragraph 1-7, TM 5-3610-287-10. For a detailed description of the Section electrical system, refer to TSS Press Section wiring diagram at the end of this manual.

Section III. TECHNICAL PRINCIPLES OF OPERATION

1-9. GENERAL. The TSS Printing Press Section is an expandable container which houses and supports the TSS Printing Press. Major systems are described for the operator in TM 5-3610-287-10. Technical Principles of Operation for Organizational, Direct Support, and General Support maintenance personnel are presented below.

1-9. GENERAL (CONT)

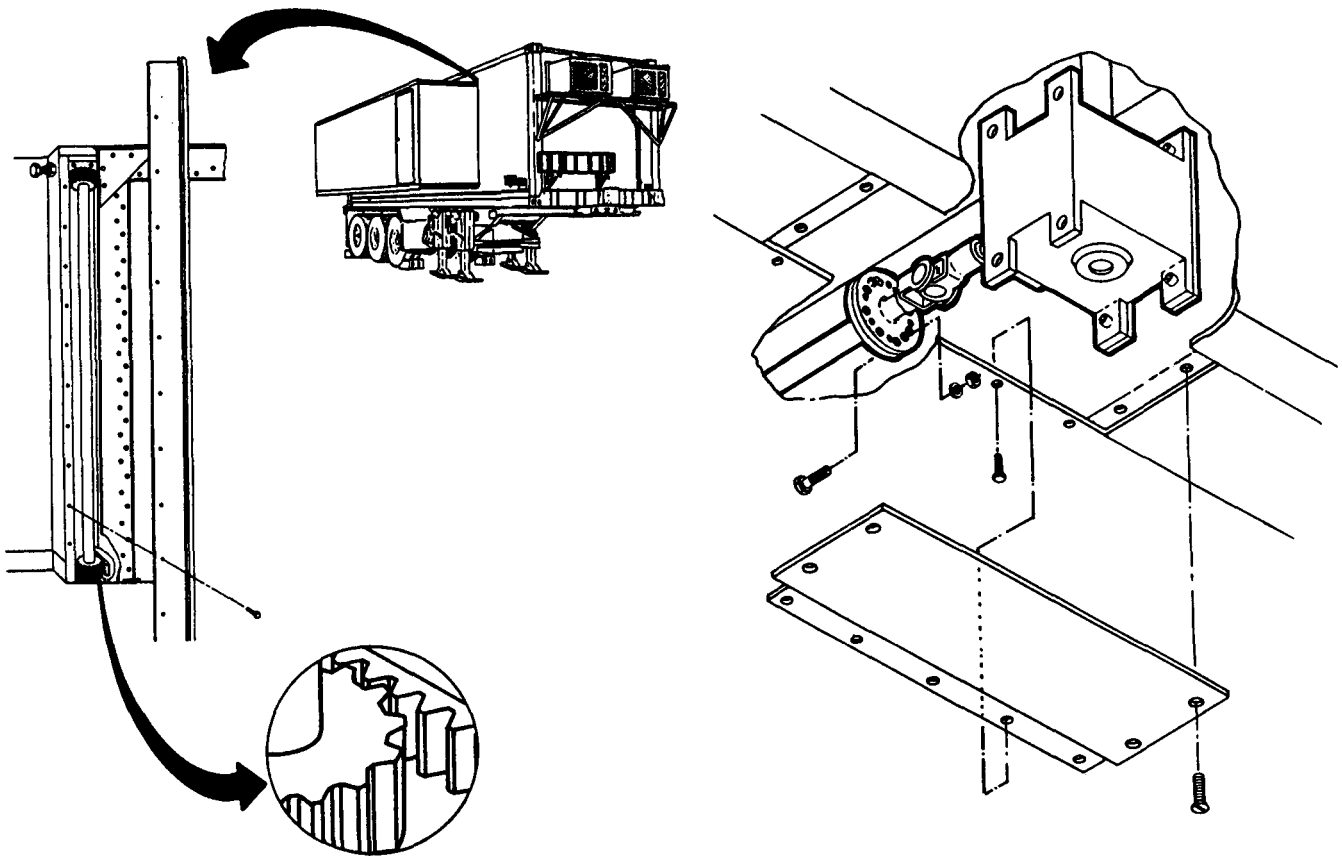

a. Expanding Side System. The expanding side system is operated with a handcrank which drives the gears and shafts to expand and retract the expanding sides.

The handcrank drives a shaft connected to a bevel gear drive. The bevel gear drive transfers energy to two other bevel gear drives and two right angle speed reducers. Synchronized operation of the bevel gear drives and right angle speed reducers allows easy operation and equal extension of sides. Vertical and horizontal shafts transfer energy from the handcrank to the bevel gear drives and then to the right angle speed reducers. The expanding side can be adjusted by disengaging the retainer block and moving the expanding side in or out. Handwinches allow the folding floors to be raised and lowered by one person.

b. Electrical System. The electrical system controls and distributes electrical power throughout the Section. Two hundred and eight volt, three-phase power enters the Section through the main power cable at the power entry panel. From the power entry panel, power is sent through conduit up to the main power switch, which controls all power coming into

the Section. The main power switch feeds power to the load center through the main circuit breaker, where power is divided into individual circuits controlled by circuit breakers. Individual circuit breakers control power to various systems and appliances. For a detailed description of the Section electrical system, refer to TSS Press Section wiring diagram at the end of this manual.

The power monitor assembly provides phase, frequency, and voltage information on 3-phase power coming into the Section. Each power phase is monitored by the power monitor assembly through lead wires connected ahead of the main power switch. The power monitor assembly is used to check incoming power for proper phase, voltage, and frequency before it is switched to the circuit breaker control panel. Monitoring for proper voltage, phase, and frequency of power before powering up the Section prevents damage to Section equipment. The frequency meter measures frequency of each phase of power coming into the Section in cycles per second. Correct frequency for the Section is 60 Hz. The voltage meter measures voltage of each phase of input power. Correct voltage is 120 Vac. The phase selector switch allows monitoring of incoming voltage and frequency by selecting each of the three phases of power. The power monitor assembly is protected by a 250-volt, 1 amp fuse.

The electrical system supports three types of lighting systems in the Section. These systems are the fluorescent light system, the blackout light system, and the dome lights.

The fluorescent light system consists of nine fluorescent lights with individual ON/OFF switches. Each light fixture has two 40-watt lamps. A radio frequency (RF) filter is provided to filter out electromagnetic interference (EMI) produced by the fluorescent light. The ballast increases the voltage coming into the fluorescent light.

The blackout light system has two light fixtures which light when the system is activated by opening either of the personnel doors. The blackout light system contains a relay located inside the load center, which switches power ON or OFF to the fluorescent ceiling lights, expanding side wall lights, and the blackout lights. The positions of the blackout light switch and blackout bypass switch determine which light system will be activated by the relay. When the blackout light switch is in the ON position, ac power is available to be channeled through the relay to the ceiling blackout lights depending on the positions of the blackout bypass switch and door switch. The blackout bypass switch activates the blackout relay to bypass the system and returns lighting to normal operation.

The dome lights operate independently of all Section systems on 12-volt dc power supplied by an external source. Switches mounted on each dome light control ON/OFF operation.

The plumbing electrical system is designed to provide heated or ambient-temperature water upon demand for the press operator. It consists of a main pump ON/OFF switch, water heater ON/OFF switch, and temperature control switch. Power is distributed at a junction box under the sink.

1-9. GENERAL (CONT)

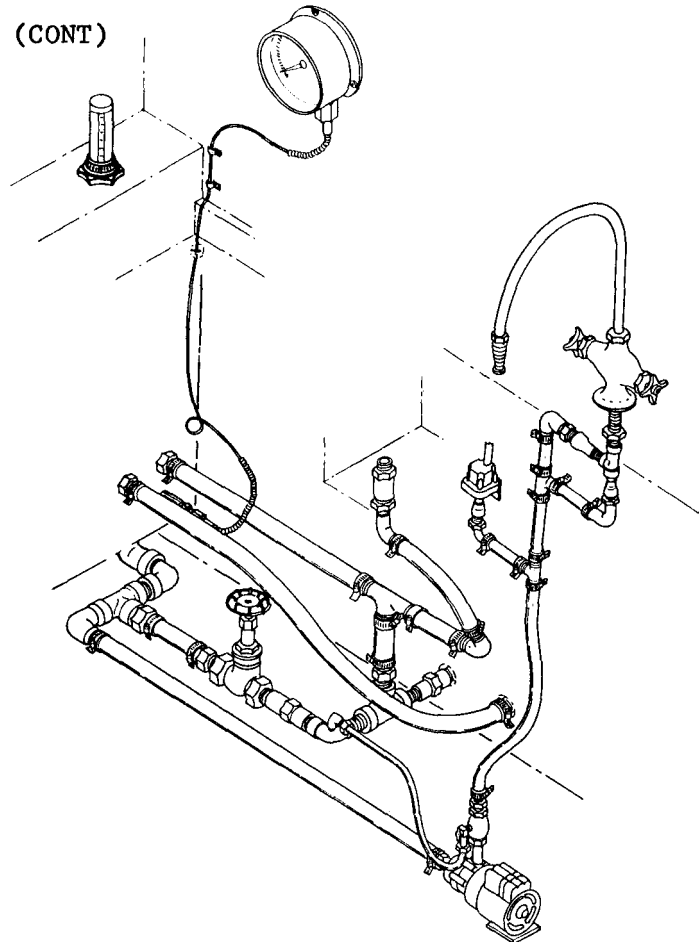

c. Plumbing System. The plumbing system provides water for Printing Press operation and cleanup.

Water is pumped by the auxiliary pump into the water tank through the water inlet on the water box. The auxiliary pump has a 1/2-horsepower 115-volt motor. Water is stored in the 36-gallon water tank until it is pumped by the main pump up to the faucet assembly. An adjustable immersion heater at the bottom of the tank allows selection of a range of water temperatures. The main pump has 1/8-horsepower 115-volt motor with a rating of 14 psi.

The pressure switch controls operation of the main pump in response to the pressure in the faucet water piping. It activates the main pump when water pressure falls and shuts down the main pump when proper pressure is reached. The pressure switch is adjusted by a screw +10 psi from the standard 14 psi.

Water is pumped from the water tank to the faucet assembly and sink. The faucet assembly controls rate of water flow.

As water drains from the sink, it flows through a hose to the water box drain pipe and out of the Section for disposal. An angle valve is located on the sink drain pipe to drain the faucet plumbing.

1-9. GENERAL (CONT)

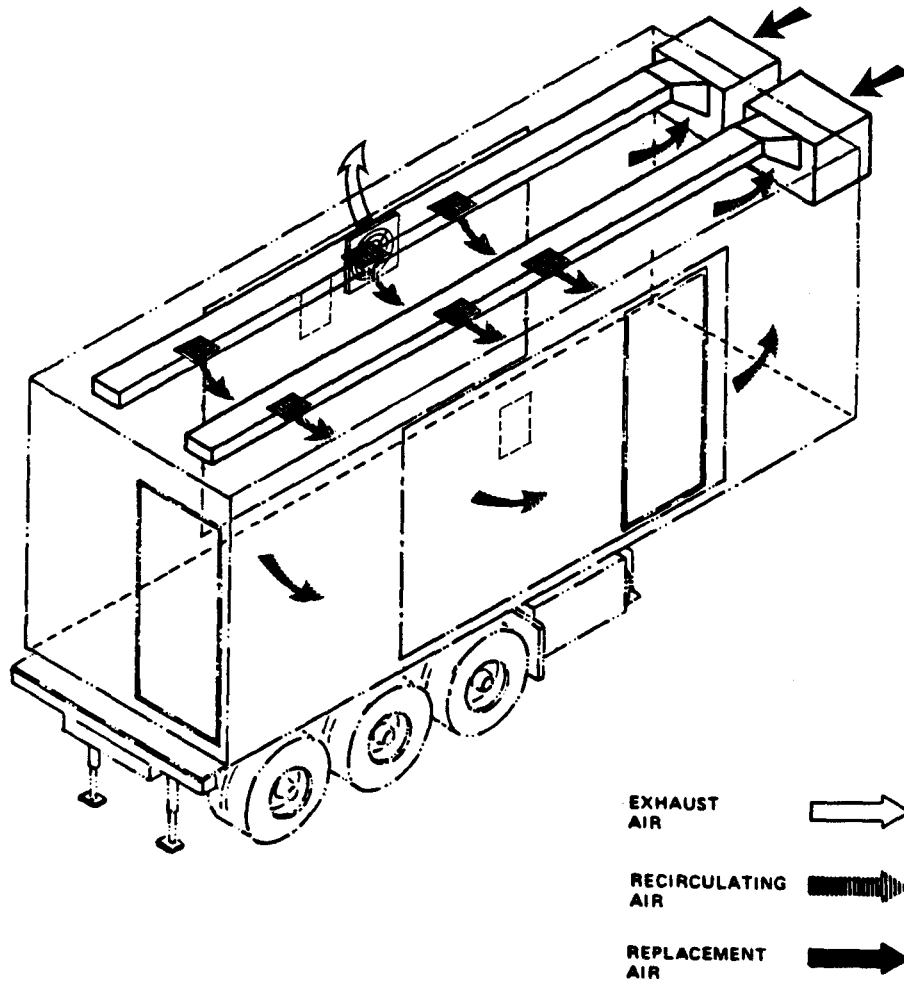

d. Ventilation and Exhaust System. The ventilation and exhaust system provides temperature control and ventilation for the Section interior. Excess humidity can be controlled to a certain level. The ventilation system is designed to maintain a proper environment for press operation only when kept in continuous use.

The exhaust fan has a 120-volt fan motor with an ON/OFF switch mounted to the wall. A foam filter and louvers on the housing prevent light from escaping the Section. When not in use, the exhaust fan cover can be secured.

1-9. GENERAL (CONT)

Air is pulled into the ventilation system's two air conditioner/heater units at inlet louvers where it is filtered by fiberglass filters. The air is then either heated or cooled or distributed through the ducts and vents.

The air conditioner/heaters warm and cool the Section and provide ventilation through a ceiling-mounted duct system with six vents. They are designed to heat in ambient temperatures as low as -50°F (10°C) and to cool in ambient temperatures as high as 120°F (49°C). The air conditioner/heaters have a cooling capacity of 18,000 BTU/Hour and a maximum heating capacity of 14,300 BTU/Hour.

The air conditioner/heaters are operated by control panels on the top left corners of each air conditioner/heater unit. Each control panel has switches for selecting heating, cooling, or ventilation; fan speed; and temperature level. A control circuit breaker and a compressor circuit breaker are also provided to protect the compressor and other electrical components in the air conditioner/heaters. For additional information on the air conditioner/heaters, refer to TM 5-4120-367-14.

For colder temperatures, supplemental heat is provided by wall heaters in each expanding side. The wall heaters operate on 3,000 watts and 208 volts with 60 Hz alternating current. Temperature is controlled by a switch on each wall heater grill.

CHAPTER 2

ORGANIZATIONAL MAINTENANCE

Section I. REPAIR PARTS; SPECIAL TOOLS; TEST, MEASUREMENT, AND DIAGNOSTIC EQUIPMENT (TMDE); AND SUPPORT EQUIPMENT

2-1. COMMON TOOLS AND EQUIPMENT. For authorized common tools and equipment, refer to the Modified Table of Organization and Equipment (MTOE) applicable to your unit.

2-2. SPECIAL TOOLS, TMDE, AND SUPPORT EQUIPMENT. For repair of the Section at organizational maintenance, refer to the repair parts and special tools list (RPSTL), TM 5-3610-287-24P, and to the Maintenance Allocation Chart (MAC), appendix B of this manual.

2-3. REPAIR PARTS. Repair parts are listed and illustrated in the repair parts and special tools list (RPSTL), TM 5-3610-287-24P, covering organizational maintenance for this equipment.

Section II. SERVICE UPON RECEIPT

2-4. SITE REQUIREMENTS. The Section should be located on firm, level ground. Allow ample space for expanding the sides to prevent contact with power lines and other obstructions.

2-5. SERVICE UPON RECEIPT OF MATERIEL. The following inspections listed in table 2-1 should be made upon receipt of the Section.

Table 2-1. Service Upon Receipt of Materiel

LOCATION	ITEM	ACTION	REMARKS
1. Exterior	Shell and Exterior Components	a. Inspect all four sides, top, and bottom for dents, punctures, loose parts, missing components, and for corrosion. b. Reject Section if damage will prevent proper operation.	Para 2-62

Table 2-1. Service Upon Receipt of Materiel (Cont)

LOCATION	ITEM	ACTION	REMARKS
2. Interior	Equipment and Shell	a. Inspect for broken or loose equipment, corrosion, or evidence of water leakage. b. Report damaged equipment in accordance with AR 735-11 and AR 735-11-2.	
3. Interior	Personnel and Equipment Doors, Air Vents, and Expanding Sides	a. Inspect for damage, worn seals, light leaks, and corrosion. b. Report damaged items in accordance with AR 735-11 and AR 735-11-2.	Para 2-64 and para 2-65.
4. Interior	Contents and Supplies	a. Inventory contents against Components of End Item and Basic Issue Items Lists. Inventory supplies against Expendable/Durable Materials List. b. Report discrepancies in accordance with AR 735-11 and AR 735-11-2.	TM 5-3610-287-10, appendix B. Appendix C of this manual and in TM 5-3610-287-10, appendix D.

2-6. CHECKING UNPACKED EQUIPMENT

a. Inspect the Section for damage incurred during shipment. If the equipment has been damaged, report the damage on SF Form 364, Report of Discrepancy (ROD).

2-6. CHECKING UNPACKED EQUIPMENT (CONT)

b. Check the equipment against the packing slip to see if the shipment is complete. Report all discrepancies in accordance with the instructions of DA PAM 738-750.

c. Check to see whether the equipment has been modified.

2-7. PRELIMINARY SERVICE. Check lubrication of Section components as outlined in the lubrication order LO 5-3610-287-12.

2-8. OPERATIONAL CHECK. Perform all organizational Preventive Maintenance Checks and Services (PMCS) required by table 2-2. If necessary, perform operator's PMCS, table 2-1, TM 5-3610-287-10. If problems exist, troubleshoot in accordance with troubleshooting procedures of this manual (table 2-3) and perform the necessary corrective actions.

Section III. ORGANIZATIONAL PREVENTIVE MAINTENANCE CHECKS AND SERVICES (PMCS)

2-9. GENERAL . The Section must be inspected and serviced regularly to find and correct defects.

a. Your Preventive Maintenance Checks and Services table lists the inspection and care of your equipment required to keep it in good operating condition.

b. Use the "Item No." column of the PMCS table to supply the item number used in the "TM Number" column of DA Form 2404.

c. The interval column of your PMCS table tells you when to do a certain check or service.

d. The procedure column of your PMCS table tells you how to do the required check and service. Carefully follow these instructions.

e. If your equipment does not perform as required, refer to table 2-3, Organizational Troubleshooting. Report malfunctions or failures on DA Form 2404, or refer to DA PAM 738-750.

f. Refer to TM 5-4120-367-14 for PMCS on air conditioner/heaters.

g. Refer to TM 5-2330-305-14 for PMCS on semitrailer chassis.

Table 2-2. Organizational Preventive Maintenance Checks and Services

Q - Quarterly

Item No.	Interval 0	Item To Be Inspected Procedure
1	●	<p>MODIFIED SECTION ASSEMBLY.</p> <p>a. Check that bolts, nuts, and rivets are present and not loose, rusted, or broken.</p> <p>b. Check for loose or chipped paint, rust, and gaps at welded areas.</p>
2	●	<p>AIR CONDITIONER/HEATER SUPPORT BRACKETS.</p> <p>a. Inspect welds on air conditioner/heater brackets for cracks. Refer equipment to direct support/general support maintenance for repair of welds.</p> <p>b. Inspect for loose or missing bolts securing air conditioner/ heater brackets to Section.</p>
3	●	<p>AIR CONDITIONER/HEATER DRAIN TUBES.</p> <p>Inspect air conditioner/heater drain tubes for cracks or looseness.</p>

Section IV. ORGANIZATIONAL TROUBLESHOOTING

2-10. GENERAL. This section contains the checks and corrective actions for the organizational technician to troubleshoot the Section and its components. The table lists common malfunctions you may find during operation or maintenance of the Section. The tests/inspections and corrective actions should be performed in the order listed.

This manual cannot list all malfunctions, tests/inspections, or corrective actions. If a malfunction is not listed or is not corrected by the listed corrective actions, notify your supervisor.

SYMPTOM INDEX

	Troubleshooting Procedure Page
EMERGENCY LIGHT SET	
Indicator lamp does not light when plugged in	2-6
One lamp fails to light when tested	2-7
Lamps are dim or fail to light when tested	2-8
Figure 2-1. Emergency Light Set Simplified Schematic	2-30
AIR CONDITIONER/HEATER	
Does not operate	2-9
Does not cool	2-10
MAIN PUMP	
Does not operate	2-10
Operates intermittently, low water pressure	2-11
WATER TANK	
No hot water from water tank	2-12
TELEPHONE	
Does not operate	2-13
POWER ENTRY PANEL	
Duplex receptacle does not operate	2-13
No power to Section	2-14
POWER MONITOR ASSEMBLY	
Phase and/or voltage meters do not operate	2-15
Phase lights do not operate	2-16
Figure 2-2. Power Monitor Assembly Simplified Schematic	2-31
LOAD CENTER	
Circuit breaker does not operate	2-17
Circuit breaker continually trips	2-18
BLACKOUT LIGHT SYSTEM	
Blackout lights come on when system is activated	2-18
Ceiling lights do not operate	2-20
DOME LIGHT	
Does not operate	2-21
ON/OFF SWITCH	
Does not operate	2-23

SYMPTOM INDEX (CONT)

	Troubleshooting Procedure Page
WALL OUTLET	
Does not operate	2-24
EXHAUST FAN	
Does not operate	2-25
WALL HEATER	
Does not operate	2-26
Blows cold air	2-27
Heat rises but fan does not operate	2-27
Circuit breaker continually trips	2-28
PRESS	
Does not operate	2-29

Table 2-3. Organizational Troubleshooting

MALFUNCTION

TEST OR INSPECTION

CORRECTIVE ACTION

1. EMERGENCY LIGHT SET INDICATOR LAMP DOES NOT LIGHT WHEN PLUGGED IN.

Step 1. Check that circuit breaker is ON.

Set circuit breaker to ON.

WARNING

HIGH VOLTAGE. When working on high voltage components, always have an additional person present. Keep one hand away from equipment to reduce hazard of current flowing through vital organs of body. Remove all jewelry from fingers, wrists, and neck before working on electrical components. Failure to observe this warning may result in death or serious burns.

Step 2. Check voltage at emergency light wall outlet. Reading should be 110 ±5 Vac.

Troubleshoot wall outlet (malfunction 20).

Table 2-3. Organizational Troubleshooting (Cont)

MALFUNCTION	TEST OR INSPECTION	CORRECTIVE ACTION
1. EMERGENCY LIGHT SET INDICATOR LAMP DOES NOT LIGHT WHEN PLUGGED IN (CONT)	Step 3. Unplug emergency light set. Remove front cover and check for broken or loose wires.	Repair or replace wires. Refer to figure 2-1, Emergency Light Set Simplified Schematic, at end of troubleshooting table.
	Step 4. Plug in emergency light set. Test voltage on circuit card from CT to X ₁ , then from CT to X ₂ . Reading should be 8.8 Vac.	If reading is not correct, replace transformer (para 2-21). If malfunction still exists, replace indicator bulb. If malfunction still exists, replace circuit card (para 2-21).
2. ONE EMERGENCY LIGHT SET LAMP FAILS TO LIGHT WHEN TESTED.		
		<u>WARNING</u>
		HIGH VOLTAGE. When working on high voltage components, always have an additional person present. Keep one hand away from equipment to reduce hazard of current flowing through vital organs of body. Remove all jewelry from fingers, wrists, and neck before working on electrical components. Failure to observe this warning may result in death or serious burns.
	Set toggle switch to OFF and unplug emergency light set. Check for corrosion at bulb base and socket.	
	Clean bulb base or socket. If malfunction still exists, replace bulb.	

Table 2-3. Organizational Troubleshooting (Cont)

MALFUNCTION	
TEST OR INSPECTION	CORRECTIVE ACTION
3. EMERGENCY LIGHT SET LAMPS ARE DIM OR FAIL TO LIGHT WHEN TESTED.	
Step 1. Check that toggle switch is ON.	Set toggle switch to ON.
	<u>WARNING</u>
	HIGH VOLTAGE. When working on high voltage components, always have an additional person present. Keep one hand away from equipment to reduce hazard of current flowing through vital organs of body. Remove all jewelry from fingers, wrists, and neck before working on electrical components. Failure to observe this warning may result in death or serious burns.
Step 2. Set toggle switch to OFF and unplug emergency light set. Remove front cover and check for broken or loose wires.	Repair or replace wires. Refer to figure 2-1, Emergency Light Set Simplified Schematic, at end of troubleshooting table.
Step 3. Set toggle switch to OFF and plug in emergency light set. Test voltage across B- terminal and B+ terminal on circuit card. Reading should be 6.5 +0.3 Vdc.	If reading is correct, go to step 6.
Step 4. Test voltage on circuit card from CT to X ₁ , then from CT to X ₂ . Reading should be 8.8 +1 Vac.	If reading is not correct, replace transformer (para 2-21).
Step 5. Unplug emergency light set. Remove red lead from battery post. Set toggle switch to ON and test continuity across toggle switch terminals. Reading should be 0 ohms.	

Table 2-3. Organizational Troubleshooting (Cont)

MALFUNCTION	TEST OR INSPECTION	CORRECTIVE ACTION
3. EMERGENCY LIGHT SET LAMPS ARE DIM OR FAIL TO LIGHT WHEN TESTED (CONT)	<p>If reading is not 0 ohms, replace toggle switch (para 2-21). If reading is 0 ohms, replace circuit card (para 2-21).</p> <p>Step 6. Test voltage at battery terminals. Reading should be 6.5 ±0.3 Vdc.</p>	<p>If reading is less than 6.2 Vdc, replace battery (para 2-21).</p>
4. AIR CONDITIONER/HEATER DOES NOT OPERATE.	<p>Step 1. Check that circuit breakers in power panel and front of air conditioner/heater are ON.</p> <p>Set circuit breakers to ON.</p>	<p style="text-align: center;"><u>WARNING</u></p> <p>HIGH VOLTAGE. When working on high voltage components, always have an additional person present. Keep one hand away from equipment to reduce hazard of current flowing through vital organs of body. Remove all jewelry from fingers, wrists, and neck before working on electrical components. Failure to observe this warning may result in death or serious burns.</p>
	<p>Step 2. Turn air conditioner/heater to OFF. Disconnect power cable from front panel. Test voltage from ground (connector pin D) to connector pins A, B, and C in cable plug. All three readings should be 110 ±10 Vat.</p>	<p>If voltage is correct, troubleshoot air conditioner/heater unit in accordance with TM 5-4120-367-14. If voltage is incorrect, troubleshoot circuit breaker (malfunction 14).</p>

Table 2-3. Organizational Troubleshooting (Cont)

MALFUNCTION

TEST OR INSPECTION

CORRECTIVE ACTION

5. AIR CONDITIONER/HEATER DOES NOT COOL.

Check air conditioner/heater controls for proper settings.

Set air conditioner/heater controls to proper settings.
If malfunction still exists, troubleshoot air conditioner/
heater unit in accordance with TM 5-4120-367-14.

6. MAIN/PUMP DOES NOT OPERATE.

Step 1. Check that WATER PUMP switch and circuit breaker are on.

Set WATER PUMP switch and WATER PUMP/HEATER circuit
breaker to ON.

WARNING

HIGH VOLTAGE. When working on high voltage
components, always have an additional person
present. Keep one hand away from equipment to
reduce hazard of current flowing through vital
organs of body. Remove all jewelry from
fingers, wrists, and neck before working on
electrical components. Failure to observe this
warning may result in death or serious burns.

Step 2. Set WATER PUMP/HEATER circuit breaker to OFF. Remove cover
plate on water pump wiring junction box under sink. Set
WATER PUMP/HEATER circuit breaker to ON. Test voltage
across input wires to junction box. Reading should be 110
±10 Vat.

If reading is 0 Vat, troubleshoot ON/OFF switch
(malfunction 19).

If reading is less than 100 Vat, check voltage at power
monitor assembly and adjust generator voltage output.

Step 3. Set WATER PUMP/HEATER circuit breaker to OFF. Disconnect
pressure switch wire leading to main pump. Set WATER PUMP/
HEATER circuit breaker to ON. Test voltage between
disconnected pressure switch wire and ground. Reading
should be 110 ±10 Vat. Open faucet handle. Reading should
be 0 Vac.

If readings are correct, replace main pump (para 2-43).

Table 2-3. Organizational Troubleshooting (Cont)

MALFUNCTION
TEST OR INSPECTION
CORRECTIVE ACTION
6. MAIN PUMP DOES NOT OPERATE (CONT)
Step 4. Remove top cover on pressure switch and turn adjusting screw to left. Retest voltage as in step 3.
If reading is correct, set circuit breaker to OFF and reconnect wiring. Pump will be operational. If reading is incorrect, replace pressure switch (para 2-42).
7. MAIN PUMP OPERATES INTERMITTENTLY, LOW WATER PRESSURE.
Step 1. Check water tank level.
Refill water tank.
Step 2. Check that angle valve is off.
Turn angle valve to right (off).
Step 3. Visually check water lines for clogs or leaks.
Replace or unclog water lines.
Step 4. Visually check main pump for seam/gasket leaks.
Replace main pump (para 2-43).
<u>WARNING</u>
HIGH VOLTAGE. When working on high voltage components, always have an additional person present. Keep one hand away from equipment to reduce hazard of current flowing through vital organs of body. Remove all jewelry from fingers, wrists, and neck before working on electrical components. Failure to observe this warning may result in death or serious burns.
Step 5. Remove top cover from pressure switch and turn pressure switch adjustment to left.
Replace pressure switch (para 2-42).

Table 2-3. Organizational Troubleshooting (Cont)

MALFUNCTION

TEST OR INSPECTION

CORRECTIVE ACTION

8. NO HOT WATER FROM WATER TANK.

Step 1. Check that IMMERSION HEATER switch is ON.

Set IMMERSION HEATER switch to ON. Wait 20 minutes and test water temperature.

Step 2. Remove lower cover from bottom of water tank and check that thermostat is set to proper temperature.

Set thermostat to proper temperature. Wait 20 minutes and test water temperature.

WARNING

HIGH VOLTAGE. When working on high voltage components, always have an additional person present. Keep one hand away from equipment to reduce hazard of current flowing through vital organs of body. Remove all jewelry from fingers, wrists, and neck before working on electrical components. Failure to observe this warning may result in death or serious burns.

Step 3. Set IMMERSION HEATER switch to OFF. Remove wall plate under sink and disconnect black wire leading to immersion heater. Set IMMERSION HEATER switch to ON. Test voltage across white and black wires leading to immersion heater. Reading should be 110 ±10 Vat.

If reading is 0 Vat, troubleshoot ON/OFF switch (malfunction 19).

Step 4. Set IMMERSION HEATER switch to OFF. Connect black wire at wall plate. Partially remove immersion heater (para 2-44). Remove black wire from immersion heater. Set IMMERSION HEATER switch to ON. Test voltage across white and black wires at immersion heater. Reading should be 110 ±10 Vat.

If voltage is 0 Vac, replace wiring from wall plate to immersion heater.

If voltage is 110 ±10 Vac, replace immersion heater (para 2-44).

Table 2-3. Organizational Troubleshooting (Cont)

MALFUNCTION
TEST OR INSPECTION
CORRECTIVE ACTION
<p>9. TELEPHONE DOES NOT OPERATE.</p> <p>Step 1. Check that interior and exterior telephone wires are connected to proper posts.</p> <p style="padding-left: 40px;">Connect wires to proper binding posts.</p> <p>Step 2. Remove telephone handset and connect to external telephone lines.</p> <p style="padding-left: 40px;">Replace telephone handset.</p> <p>Step 3. Remove lower receptacle cover and upper binding posts plate. Test continuity of telephone wires. Reading should be 0 ohms.</p> <p style="padding-left: 40px;">Replace wiring (para 2-47).</p> <p>Step 4. Test continuity of each wire to ground. Reading should be 1.0 ohm (infinite).</p> <p style="padding-left: 40px;">Replace binding posts (para 2-47).</p>
<p>10. POWER ENTRY PANEL DUPLEX RECEPTACLE DOES NOT OPERATE.</p> <p>Step 1. Check that EXTERIOR OUTLET circuit breaker is ON.</p> <p style="padding-left: 40px;">Set circuit breaker to ON.</p> <p style="text-align: center;"><u>WARNING</u></p> <p style="padding-left: 80px;">HIGH VOLTAGE. When working on high voltage components, always have an additional person present. Keep one hand away from equipment to reduce hazard of current flowing through vital organs of body. Remove all jewelry from fingers, wrists, and neck before working on electrical components. Failure to observe this warning may result in death or serious burns.</p> <p>Step 2. Set MAIN POWER switch to OFF. Remove circuit breaker cover panel. Set MAIN POWER switch to ON. Test voltage at circuit breaker. Reading should be 110 ±10 Vac.</p> <p style="padding-left: 40px;">Replace circuit breaker (para 2-51).</p>

Table 2-3. Organizational Troubleshooting (Cont)

MALFUNCTION	TEST OR INSPECTION	CORRECTIVE ACTION
10. POWER ENTRY PANEL DUPLEX RECEPTACLE DOES NOT OPERATE (CONT)		<p data-bbox="865 506 981 536" style="text-align: center;"><u>WARNING</u></p> <p data-bbox="558 570 1318 697">Turn off main power switch and disconnect main power cable before performing this task. Failure to do so may result in death or serious injury.</p> <p data-bbox="332 732 1433 859">Step 3. Set MAIN POWER switch to OFF and disconnect main power cable. Remove power entry panel cover. Tag and disconnect wires from exterior receptacle. Test continuity of each wire. Readings should be 0 ohms.</p> <p data-bbox="525 889 1433 983">If readings are not correct, replace defective wiring. If readings are correct, replace duplex receptacle (para 2-48).</p>
11. NO POWER TO SECTION.		<p data-bbox="332 1081 1400 1140">Step 1. Check that MAIN POWER switch and MAIN circuit breaker are ON.</p> <p data-bbox="525 1174 1377 1204">Set MAIN POWER switch and MAIN circuit breaker to ON.</p> <p data-bbox="865 1238 981 1268" style="text-align: center;"><u>WARNING</u></p> <p data-bbox="558 1302 1318 1557">HIGH VOLTAGE. When working on high voltage components, always have an additional person present. Keep one hand away from equipment to reduce hazard of current flowing through vital organs of body. Remove all jewelry from fingers, wrists, and neck before working on electrical components. Failure to observe this warning may result in death or serious burns.</p> <p data-bbox="332 1591 1394 1719">Step 2. Set MAIN POWER switch to OFF. Open door on MAIN POWER Switch. Set MAIN POWER switch to ON. Test voltage from ground to upper and lower terminals on MAIN POWER switch. Readings should be 110 ±5 Vac on each terminal.</p> <p data-bbox="525 1753 1334 1813">If voltage is not correct on upper terminals, test voltage at power cable and generator.</p>

Table 2-3. Organizational Troubleshooting (Cont)

MALFUNCTION**TEST OR INSPECTION****CORRECTIVE ACTION****11. NO POWER TO SECTION (CONT)**

If voltage is correct on upper terminals but not correct on lower terminals, replace MAIN POWER switch (para 2-51).

If voltage is correct, troubleshoot MAIN circuit breaker (malfunction 14).

12. PHASE AND/OR VOLTAGE METERS DO NOT OPERATE.

Step 1. Remove fuse and test for continuity. Reading should be 0 ohms.

Replace fuse.

WARNING

- Main power cable MUST be disconnected from Section before performing maintenance on power monitor assembly. Wiring to power monitor assembly comes directly from main power input receptacle. Failure to disconnect main power cable WILL result in death or serious injury.
- HIGH VOLTAGE. When working on high voltage components, always have an additional person present. Keep one hand away from equipment to reduce hazard of current flowing through vital organs of body. Remove all jewelry from fingers, wrists, and neck before working on electrical components. Failure to observe this warning may result in death or serious burns.

Step 2. Install fuse. Set MAIN POWER switch to OFF and disconnect main power cable. Remove power monitor assembly and place on load center. Check for loose or broken wires.

Repair wiring. Refer to figure 2-2, Power Monitor Assembly Simplified Schematic, sheet 2 of 2, at end of troubleshooting table.

Table 2-3. Organizational Troubleshooting (Cont)

MALFUNCTION

TEST OR INSPECTION

CORRECTIVE ACTION

12. PHASE AND/OR VOLTAGE METERS DO NOT OPERATE (CONT)

Step 3. Connect main power cable and set MAIN POWER switch to ON. Test voltage across meter. Reading should be 110 ±5 Vac.

If reading is correct, replace meter (para 2-50).

Step 4. Test voltage from ground to meter terminal. Reading should be 0 Vac.

If reading is 110 ±5 Vac, repair ground connections in circuit breaker panel or replace ground wire.

13. PEASE LIGHTS DO NOT OPERATE.

Step 1. Reverse correct and incorrect phase lamp bulbs.

If correct phase light operates, replace defective bulb.

WARNING

- Main power cable MUST be disconnected from Section before performing maintenance on power monitor assembly. Wiring to power monitor assembly comes directly from main power input receptacle. Failure to disconnect main power cable WILL result in death or serious injury.
- HIGH VOLTAGE. When working on high voltage components, always have an additional person present. Keep one hand away from equipment to reduce hazard of current flowing through vital organs of body. Remove all jewelry from fingers, wrists, and neck before working on electrical components. Failure to observe this warning may result in death or serious burns.

Step 2. Set MAIN POWER switch to OFF and disconnect main power cable. Remove power monitor assembly and check for loose or broken wires.

Repair wiring.

Table 2-3. Organizational Troubleshooting (Cont)

MALFUNCTION	TEST OR INSPECTION	CORRECTIVE ACTION
13. PHASE LIGHTS DO NOT OPERATE (CONT)	<p>Step 3. Connect main power cable and set MAIN POWER switch to ON. Test voltage at points A, B, and C on circuit card to ground per wiring diagram. Refer to figure 2-2, Power Monitor Assembly Simplified Schematic, sheet 1 of 2, at end of troubleshooting table. Readings should be 110 ±5 Vac.</p>	<p>If readings are correct, replace circuit card (para 2-50). If readings are not correct, replace toggle switch (para 2-49).</p>
14 . CIRCUIT BREAKER DOES NOT OPERATE.	<p style="text-align: center;"><u>WARNING</u></p> <ul style="list-style-type: none"> ● Turn off main power switch before performing this task. Failure to do so may result in death or serious injury. ● HIGH VOLTAGE. When working on high voltage components, always have an additional person present. Keep one hand away from equipment to reduce hazard of current flowing through vital organs of body. Remove all jewelry from fingers, wrists, and neck before working on electrical components. Failure to observe this warning may result in death or serious burns. 	<p>Set MAIN POWER switch to OFF. Remove circuit breaker cover panel. Set MAIN POWER switch and suspected circuit breaker to ON. Test voltage at circuit breaker terminal(s). Readings should be 110 ±15 Vac.</p> <p>Replace circuit breaker (para 2-51). If reading is correct, refer equipment to depot maintenance for repair or replacement of wiring between circuit breaker and appliance.</p>

Table 2-3. Organizational Troubleshooting (Cont)

MALFUNCTION

TEST OR INSPECTION

CORRECTIVE ACTION

15. CIRCUIT BREAKER CONTINUALLY TRIPS.

WARNING

- Turn off main power switch before performing this task. Failure to do so may result in death or serious injury.
- HIGH VOLTAGE. When working on high voltage components, always have an additional person present. Keep one hand away from equipment to reduce hazard of current flowing through vital organs of body. Remove all jewelry from fingers, wrists, and neck before working on electrical components. Failure to observe this warning may result in death or serious burns.

Set MAIN POWER switch to OFF. Remove circuit breaker cover panel. Remove wire(s) from suspected circuit breaker. If circuit breaker has more than one pole, remove one wire at a time. Set MAIN POWER switch to ON. Set suspected circuit breaker to ON.

If circuit breaker still trips, replace circuit breaker (para 2-51).

If circuit breaker does not trip, troubleshoot appropriate appliance, lights, or wiring.

16. BLACKOUT LIGHTS COME ON WHEN BLACKOUT LIGHTS SYSTEM IS ACTIVATED.

Step 1. Check, that both personnel doors are closed.

Close personnel doors.

Table 2-3. Organizational Troubleshooting (Cont)

MALFUNCTION	TEST OR INSPECTION	CORRECTIVE ACTION
16. BLACKOUT LIGHTS COME ON WHEN BLACKOUT LIGHTS SYSTEM IS ACTIVATED (CONT)		<p style="text-align: center;"><u>WARNING</u></p> <p>HIGH VOLTAGE. When working on high voltage components, always have an additional person present. Keep one hand away from equipment to reduce hazard of current flowing through vital organs of body. Remove all jewelry from fingers, wrists, and neck before working on electrical components. Failure to observe this warning may result in death or serious burns.</p> <p>Step 2. Set CEILING LIGHTS circuit breaker to OFF. Remove rear personnel door switch. Set CEILING LIGHTS circuit breaker to ON. Test voltage from ground to both terminals of switch. Reading should be 110 ±5 Vac on one of the terminals.</p> <p style="padding-left: 40px;">Repair wiring to switch.</p> <p>Step 3. Set CEILING LIGHTS circuit breaker to OFF. Open curbside personnel door. Test continuity of rear personnel door switch. Reading should be 0 ohms when button is depressed and 1.0 (infinite) ohm when button is released.</p> <p style="padding-left: 40px;">Replace door switch (para 2-52).</p> <p>Step 4. Set CEILING LIGHTS circuit breaker to OFF. Install rear personnel door switch and close door. Remove cover on curbside expanding side cable junction box. Test voltage from ground to wire marked 13B. Reading should be 110 ±5 Vac.</p> <p style="padding-left: 40px;">Repair expanding side power cable (para 2-61).</p> <p>Step 5. Test voltage at junction box across wires marked 13B and 13C. Reading should be 110 ±5 Vat.</p> <p style="padding-left: 40px;">If reading is correct, replace curbside door switch (para 2-52). If reading is 0 Vac, repair expanding side power cable (para 2-61)</p>

Table 2-3. Organizational Troubleshooting (Cont)

MALFUNCTION

TEST OR INSPECTION

CORRECTIVE ACTION

17. CEILING LIGHTS DO NOT OPERATE.

Step 1. Check that CEILING LIGHTS circuit breaker is ON.

Set CEILING LIGHTS circuit breaker to ON.

Step 2. Check that BY-PASS, ceiling lights, and 3-WAY switches are ON.

Set switches to ON.

WARNING

HIGH VOLTAGE. When working on high voltage components, always have an additional person present. Keep one hand away from equipment to reduce hazard of current flowing through vital organs of body. Remove all jewelry from fingers, wrists, and neck before working on electrical components. Failure to observe this warning may result in death or serious burns.

Step 3. Set CEILING LIGHTS circuit breaker to OFF. Remove cover plate from 3-WAY switch at Section sink. Partially remove 3-WAY switch. Set CEILING LIGHTS circuit breaker to ON. Test voltage from ground to three terminals on 3-WAY Switch. Readings should be 110 \pm 5 Vac on two of three terminals.

If readings are correct, replace 3-WAY switch at load center (para 2-55).

If only one reading is 110 \pm 5 Vac, replace 3-WAY switch at Section sink (para 2-55).

If all readings are 0 Vac, go to next step.

Table 2-3. Organizational Troubleshooting (Cont)

MALFUNCTION**TEST OR INSPECTION**

CORRECTIVE ACTION

17. CEILING LIGHTS DO NOT OPERATE (CONT)**WARNING**

Turn off main power switch before performing this task. Failure to do so may result in death or serious injury.

- Step 4. Set MAIN POWER switch to OFF. Remove circuit breaker cover panel. Set MAIN POWER switch to ON. Test voltage from ground to wires marked 17 and 31 on blackout system relay. Readings should be 110 \pm 5 Vat.

If only 17 reads 110 \pm 5 Vat, replace relay (para 2-52).
If 17 reads 0 Vat, troubleshoot circuit breaker (malfunction 14).

18. DOME LIGHT DOES NOT OPERATE.**WARNING**

HIGH VOLTAGE. When working on high voltage components, always have an additional person present. Keep one hand away from equipment to reduce hazard of current flowing through vital organs of body. Remove all jewelry from fingers, wrists, and neck before working on electrical components. Failure to observe this warning may result in death or serious burns.

- Step 1. Check that external 12 Vdc power source is connected.

Connect external 12 Vdc power source.

- Step 2. Remove lens cover and bulb. Test voltage at bulb socket. Operate switch. Reading should be 12 Vdc.

If reading is correct, replace 12-volt bulb.

Table 2-3. Organizational Troubleshooting (Cont)

MALFUNCTION

TEST OR INSPECTION

CORRECTIVE ACTION

18. DOME LIGHT DOES NOT OPERATE (CONT)

Step 3. Remove dome light from ceiling. Test voltage between dome light wire and Section ground. Reading should be 12 Vdc.

If reading is correct , replace dome light (para 2-53).

WARNING

Turn off main power switch before performing this task. Failure to do so may result in death or serious injury.

NOTE

This step applies to dome light in expanding side only.

Step 4. Set MAIN POWER switch to OFF. Remove cover on curbside expanding side cable junction box. Test voltage on wire numbered 14 to ground. Reading should be 12 Vdc.

If reading is 12 Vdc, refer equipment to depot maintenance for repair of interior wiring.
If reading is not 12 Vdc, go to next step.

Step 5. Remove expanding side power cable connector. Test voltage from pin F of cable receptacle to ground. Reading should be 12 Vdc.

If reading is correct, repair expanding side power cable (para 2-61).

Table 2-3. Organizational Troubleshooting (Cont)

MALFUNCTION**TEST OR INSPECTION**

CORRECTIVE ACTION

18. DOME LIGHT DOES NOT OPERATE (CONT)

- Step 6. Remove circuit breaker cover panel and 5 screws on lower right side of load center (para 2-51, 12 Vdc circuit breaker). Pull panel back to access 12 Vdc circuit breaker. Test voltage at circuit breaker on both upper and lower terminals. Readings should be 12 Vdc.

If 12 Vdc is not present at lower terminal, replace 12 Vdc receptacle (para 2-48).

If 12 Vdc is present at lower terminal but not at upper terminal, replace 12 Vdc circuit breaker (para 2-51).

19. ON/OFF SWITCH DOES NOT OPERATE.**WARNING**

HIGH VOLTAGE. When working on high voltage components, always have an additional person present. Keep one hand away from equipment to reduce hazard of current flowing through vital organs of body. Remove all jewelry from fingers, wrists, and neck before working on electrical components. Failure to observe this warning may result in death or serious burns.

- Step 1. Set appropriate circuit breaker to OFF. Remove cover plate and switch from receptacle. Check for loose or broken wires.

Tighten connections or repair wires.

- Step 2. Set appropriate circuit breaker to ON. Test voltage across ON/OFF switch. Readings should be 0 Vac when switch is ON and 110 \pm 10 Vac when switch is OFF.

Replace ON/OFF switch (para 2-55).

If malfunction still exists, troubleshoot appropriate appliance or lights.

Table 2-3. Organizational Troubleshooting (Cont)

MALFUNCTION

TEST OR INSPECTION

CORRECTIVE ACTION

20. WALL OUTLET DOES NOT OPERATE.

Step 1. Check that appropriate circuit breaker is ON.

Set appropriate circuit breaker to ON.

WARNING

HIGH VOLTAGE. When working on high voltage components, always have an additional person present. Keep one hand away from equipment to reduce hazard of current flowing through vital organs of body. Remove all jewelry from fingers, wrists, and neck before working on electrical components. Failure to observe this warning may result in death or serious burns.

Step 2. Set appropriate circuit breaker to OFF. Remove cover plate and partially remove outlet. Set circuit breaker to ON. Test voltage across outlet terminals. Reading should be 110 \pm 10 Vac.

If reading is correct, replace wall outlet (para 2-56).
If reading is not correct and if defective wall outlet is in expanding side wall, go to next step.
If reading is not correct and if defective wall outlet is in Section wall, troubleshoot appropriate circuit breaker (malfunction 14).

Step 3. Remove cover from expanding side power cable junction box. Test voltage across terminals of wires marked W and 18 (curbside) or W and 22 (roadside). Reading should be 110 \pm 10 Vac.

If reading is correct, refer equipment to depot maintenance for repair of internal wiring.

Table 2-3. Organizational Troubleshooting (Cont)

MALFUNCTION

TEST OR INSPECTION

CORRECTIVE ACTION

20. WALL OUTLET DOES NOT OPERATE (CONT)

WARNING

Turn off main power switch before performing this task. Failure to do so may result in death or serious injury.

- Step 4. Set MAIN POWER switch to OFF. Remove power cable at connector. Set MAIN POWER switch to ON. Test voltage at power cable receptacle across pins lettered K and E (curbside) or D and H (roadside). Reading should be 110 ±10 Vac.

If reading is not correct, troubleshoot circuit breaker (malfunction 14).
 If reading is correct, repair expanding side power cable (para 2-61).

21. EXHAUST FAN DOES NOT OPERATE.

WARNING

HIGH VOLTAGE. When working on high voltage components, always have an additional person present. Keep one hand away from equipment to reduce hazard of current flowing through vital organs of body. Remove all jewelry from fingers, wrists, and neck before working on electrical components. Failure to observe this warning may result in death or serious burns.

- Step 1. Check that wall outlet circuit breaker is ON.

Set wall outlet circuit breaker to ON.

- Step 2. Test voltage at wall outlet. Reading should be 110 ±10 Vac.

Troubleshoot wall outlet (malfunction 20).

Table 2-3. Organizational Troubleshooting (Cont)

MALFUNCTION

TEST OR INSPECTION

CORRECTIVE ACTION

21. EXHAUST FAN DOES NOT OPERATE (CONT)

Step 3. Unplug exhaust fan. Remove switch cover plate and partially remove switch. Plug in exhaust fan. Test voltage across switch terminals. Readings should be 0 Vac with switch ON and 110 ±10 Vac with switch OFF.

If readings are not correct, replace ON/OFF switch (para 2-55).

If readings are correct, replace exhaust fan motor (para 2-58).

22. WALL HEATER DOES NOT OPERATE.

WARNING

HIGH VOLTAGE. When working on high voltage components, always have an additional person present. Keep one hand away from equipment to reduce hazard of current flowing through vital organs of body. Remove all jewelry from fingers, wrists, and neck before working on electrical components. Failure to observe this warning may result in death or serious burns.

Step 1. Check that both HEATER circuit breakers are set to ON.

Set both HEATER circuit breakers to ON.

Step 2. Set both HEATER circuit breakers to OFF. Remove wall heater control knob and grill. Check for loose or broken wires.

Repair or replace wires.

Step 3. Set both HEATER circuit breakers to ON. Test voltage across wall heater input wires. Reading should be 208 ±10 Vac.

Troubleshoot circuit breakers (malfunction 14).

Table 2-3. Organizational Troubleshooting (Cont)

MALFUNCTION	
TEST OR INSPECTION	CORRECTIVE ACTION
22. WALL HEATER DOES NOT OPERATE (CONT)	<p>Step 4. Set both HEATER circuit breakers to OFF. Remove one wire from limiting thermostat. Test continuity of limiting thermostat. Reading should be 0 ohms.</p> <p>If reading is not correct, replace limiting thermostat (para 2-60). If reading is correct, replace thermostat (para 2-60).</p>
23. WALL HEATER BLOWS COLD AIR.	<p style="text-align: center;"><u>WARNING</u></p> <p>HIGH VOLTAGE. When working on high voltage components, always have an additional person present. Keep one hand away from equipment to reduce hazard of current flowing through vital organs of body. Remove all jewelry from fingers, wrists, and neck before working on electrical components. Failure to observe this warning may result in death or serious burns.</p> <p>Set both HEATER circuit breakers to OFF. Remove knob, grill, and interior assembly. Check for broken element assembly.</p> <p>Replace element assembly (para 2-60).</p>
24. HEAT RISES FROM WALL HEATER BUT FAN DOES NOT OPERATE.	<p style="text-align: center;"><u>WARNING</u></p> <p>HIGH VOLTAGE. When working on high voltage components, always have an additional person present. Keep one hand away from equipment to reduce hazard of current flowing through vital organs of body. Remove all jewelry from fingers, wrists, and neck before working on electrical components. Failure to observe this warning may result in death or serious burns.</p> <p>Set both HEATER circuit breakers to OFF. Remove knob, grill, and interior assembly. Check for loose or broken fan wires and corrosion on terminals.</p>

Table 2-3. Organizational Troubleshooting (Cont)

MALFUNCTION

TEST OR INSPECTION

CORRECTIVE ACTION

24. HEAT RISES FROM WALL HEATER BUT FAN DOES NOT OPERATE (CONT)

If damaged, repair wiring or clean terminals.
If not damaged, replace fan motor (para 2-60).

25. WALL HEATER CIRCUIT BREAKER CONTINUALLY TRIPS.

WARNING

HIGH VOLTAGE. When working on high voltage components, always have an additional person present. Keep one hand away from equipment to reduce hazard of current flowing through vital organs of body. Remove all jewelry from fingers, wrists, and neck before working on electrical components. Failure to observe this warning may result in death or serious burns.

Step 1. Remove knob, grill, and interior assembly. Disconnect fan motor wires from heating element. Set both HEATER circuit breakers to ON.

If circuit breaker does not trip, replace fan motor (para 2-60).

Step 2. Disconnect wires from heating element and insulate wire ends by wrapping with electrical tape. Set HEATER circuit breaker to ON.

If circuit breaker does not trip, replace element assembly (para 2-60).

Step 3. Disconnect wires from limiting thermostat and insulate wire ends by wrapping with electrical tape. Set HEATER circuit breaker to ON.

If circuit breaker does not trip, replace limiting thermostat (para 2-60).

Table 2-3. Organizational Troubleshooting (Cont)

MALFUNCTION**TEST OR INSPECTION**

CORRECTIVE ACTION

25. WALL HEATER CIRCUIT BREAKER CONTINUALLY TRIPS (CONT)

Step 4. Cut blue and black input wires to wall heater below crimp connector. Insulate input wire ends by wrapping with electrical tape. Set HEATER circuit breaker to ON.

If cutting wires corrects malfunction, replace thermostat (para 2-60).

If malfunction still exists, troubleshoot circuit breaker (malfunction 14).

26. PRESS DOES NOT OPERATE.

Step 1. Check that press circuit breaker is on.

Set circuit breaker to ON.

WARNING

- Turn off main power switch before performing this task. Failure to do so may result in death or serious injury.

- **HIGH VOLTAGE.** When working on high voltage components, always have an additional person present. Keep one hand away from equipment to reduce hazard of current flowing through vital organs of body. Remove all jewelry from fingers, wrists, and neck before working on electrical components. Failure to observe this warning may result in death or serious burns.

Step 2. Set MAIN POWER switch to OFF. Remove circuit breaker cover panel. Set MAIN POWER switch to ON. Test voltage at each circuit breaker terminal. Reading should be 110 ±10 Vat.

If reading is not correct, replace circuit breaker (para 2-51).

If reading is correct, refer equipment to depot maintenance for repair.

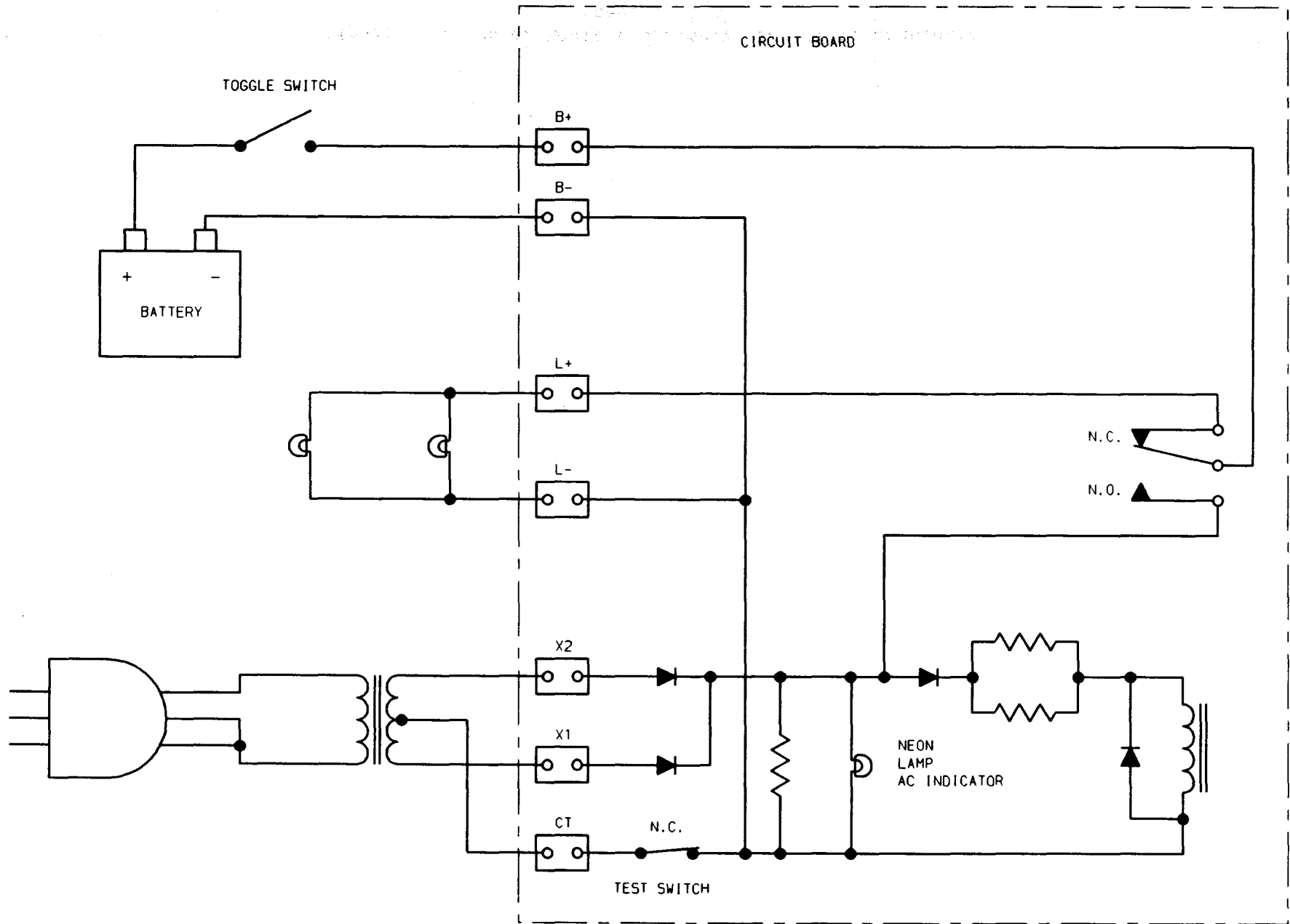

Figure 2-1. Emergency Light Set Simplified Schematic

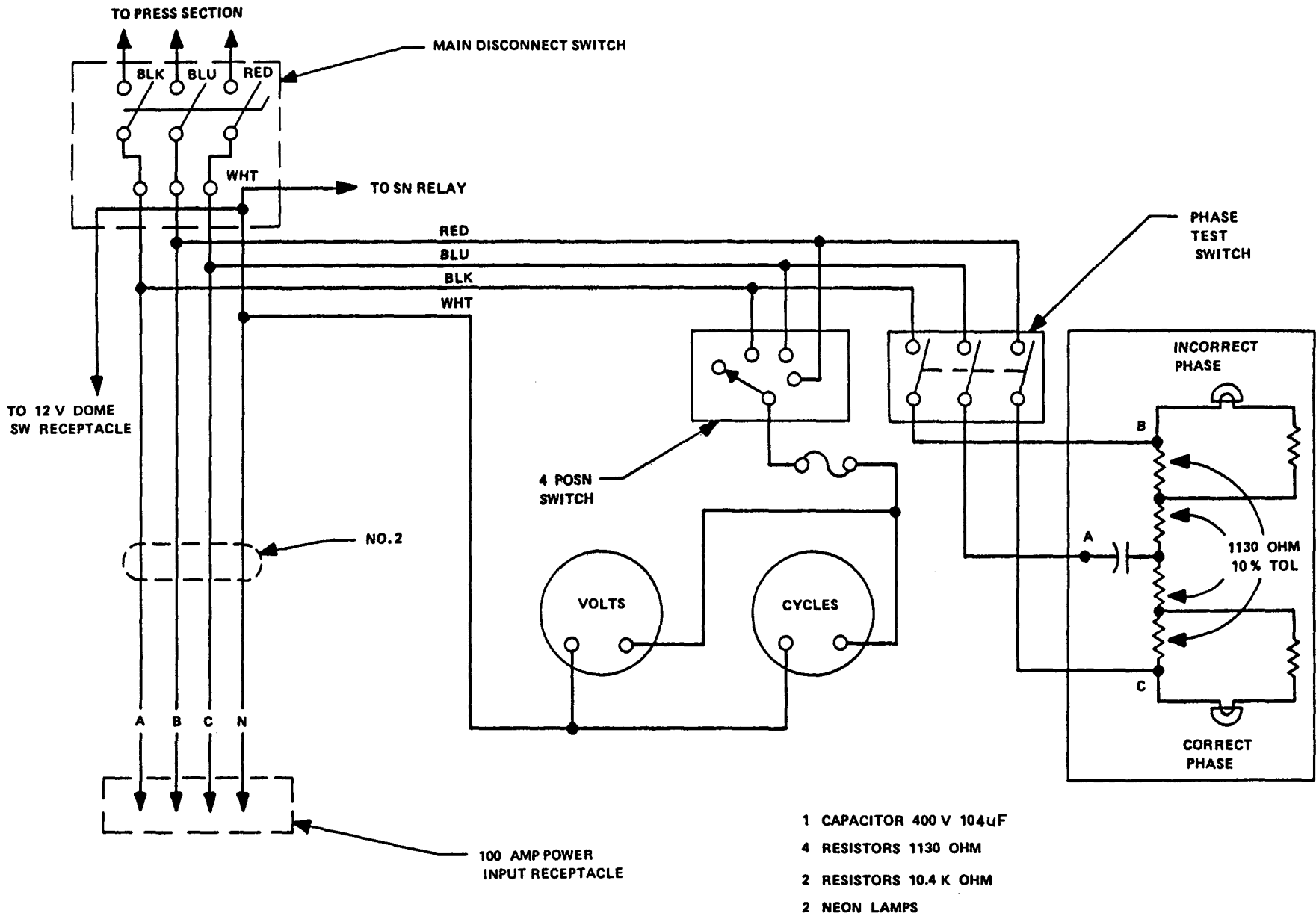

Figure 2-2. Power Monitor Assembly Simplified Schematic (Sheet 1 of 2)

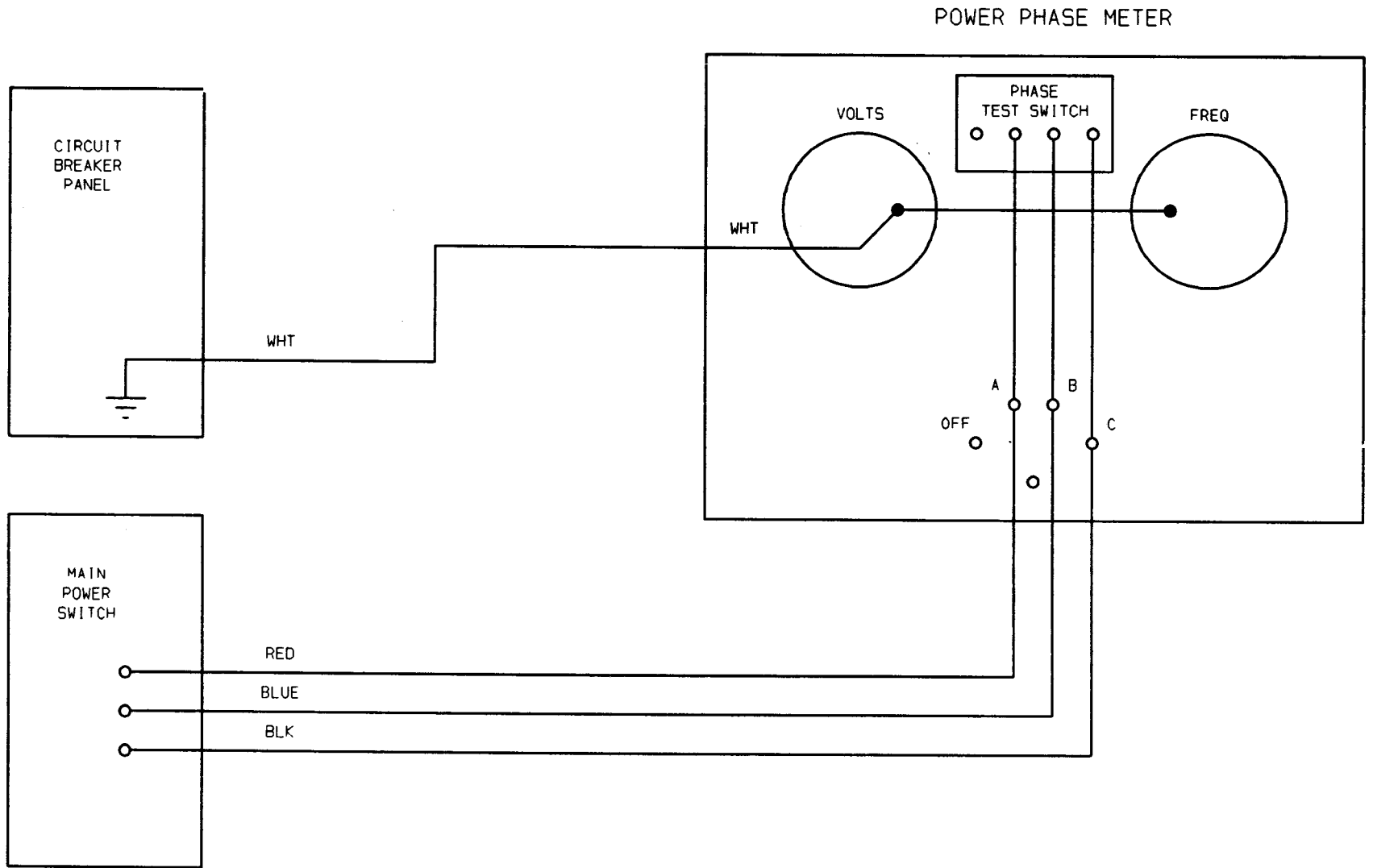

Figure 2-2. Power Monitor Assembly Simplified Schematic
(Sheet 2 of 2)

Section V. ORGANIZATIONAL MAINTENANCE PROCEDURES

2-11. GENERAL. This section contains organizational maintenance procedures as authorized by the Maintenance Allocation Chart (MAC), appendix B of this manual. The following topics are included as applicable:
 a. Adjustment b. Installation c. Removal d. Repair. All maintenance procedures in this section will be performed by one Photolithographer (Reproduction Equipment Repairer) MOS 83F20J6. When additional personnel are required for a procedure, the MOS is shown in the initial setup.

	Para		Para
Replace External Exhaust Fan Housing Assembly	2-12	Replace Spare Roller Rack Assembly	2-31
Repair External Exhaust Fan Housing Assembly	2-13	Replace Spare Roller Rack Cover	2-32
Replace Removable Floor Section Carrier Brackets	2-14	Replace Modified Five-Drawer Storage Cabinet	2-33
Repair Removable Floor Section Carrier Brackets	2-15	Repair Modified Five-Drawer Storage Cabinet	2-34
Repair Tool Caddy Assembly	2-16	Replace Jogging Table Assembly and Feeder Pile Board Storage Rack	2-35
Replace Strap and Buckle Assembly	2-17	Repair Jogging Table Assembly and Feeder Pile Board Storage Rack	2-36
Replace First Aid Kit	2-18	Repair GTO Storage Cabinet Assembly	2-37
Replace Fire Extinguisher	2-19	Replace Faucet Assembly	2-38
Replace Emergency Light Set	2-20	Repair Faucet Assembly	2-39
Repair Emergency Light Set	2-21	Replace Sink Top	2-40
Replace Mirror and Safety Chain	2-22	Replace Sink Cabinet	2-41
Repair Boarding Ladder Assembly	2-23	Repair Water Piping	2-42
Replace Folding Ladder Support Brackets	2-24	Replace Main Pump	2-43
Repair Folding Ladder Support Brackets	2-25	Repair Water" Tank Assembly	2-44
Repair Air Conditioner/Heater Mounting Bracket	2-26	Replace Water Box Assembly	2-45
Replace Wall Storage Cabinet	2-27	Repair Water Box Assembly	2-46
Repair Wall Storage Cabinet	2-28	Repair Telephone Installation	2-47
Replace Roller Storage Rack	2-29	Repair Power Entry Panel Assembly	2-48
Repair Roller Storage Rack	2-30	Replace Power Monitor Assembly	2-49
		Repair Power Monitor Assembly	2-50
		Repair Load Center	2-51
		Repair Blackout Light System	2-52
		Replace Dome Light Assembly	2-53

2-11. GENERAL (CONT)

	Para		Para
Repair Fluorescent Light	2-54	Repair Section Body Skin	
Replace ON/OFF Switch	2-55	(Temporary)	2-62
Replace Wall Outlet	2-56	Repair Inclinator	
Replace Exhaust Fan		Assembly	2-63
Assembly	2-57	Adjust Personnel/Equipment	
Repair Exhaust Fan		Door	2-64
Assembly	2-58	Repair Personnel/Equipment	
Replace Wall Heater	2-59	Door	2-65
Repair Wall Heater	2-60	Replace Winch Assembly	2-66
Repair Expanding Side Power		Repair Winch Assembly	2-67
Cable	2-61	Repair Handwinch	2-68

2-12. REPLACE EXTERNAL EXHAUST FAN HOUSING ASSEMBLY

This task covers: a. Removal b. Installation

INITIAL SETUP

Tools

- Light machine repair tool kit (appendix B, section III, item 11)
- Portable electric drill
- Twist drill set
- Rivet gun (appendix B, section III, item 10)
- Scraping knife (appendix B, section III, item 9)
- Folding ladder
- Extension cord

Materials/Parts

- External exhaust fan housing assembly, 13225E3262
- Blind rivets, MS20601-B8W6 (7 required)
- Silicone compound (appendix C, item 7)
- Rubber cement thinner (appendix C, item 33)
- Rag (appendix C, item 24)
- Paint (appendix C, items 18, 19, 20)
- Aliphatic thinner (appendix C, item 32)
- Spray kit (appendix C, item 26)

2-12. REPLACE EXTERNAL EXHAUST FAN HOUSING ASSEMBLY (CONT)

REMOVAL

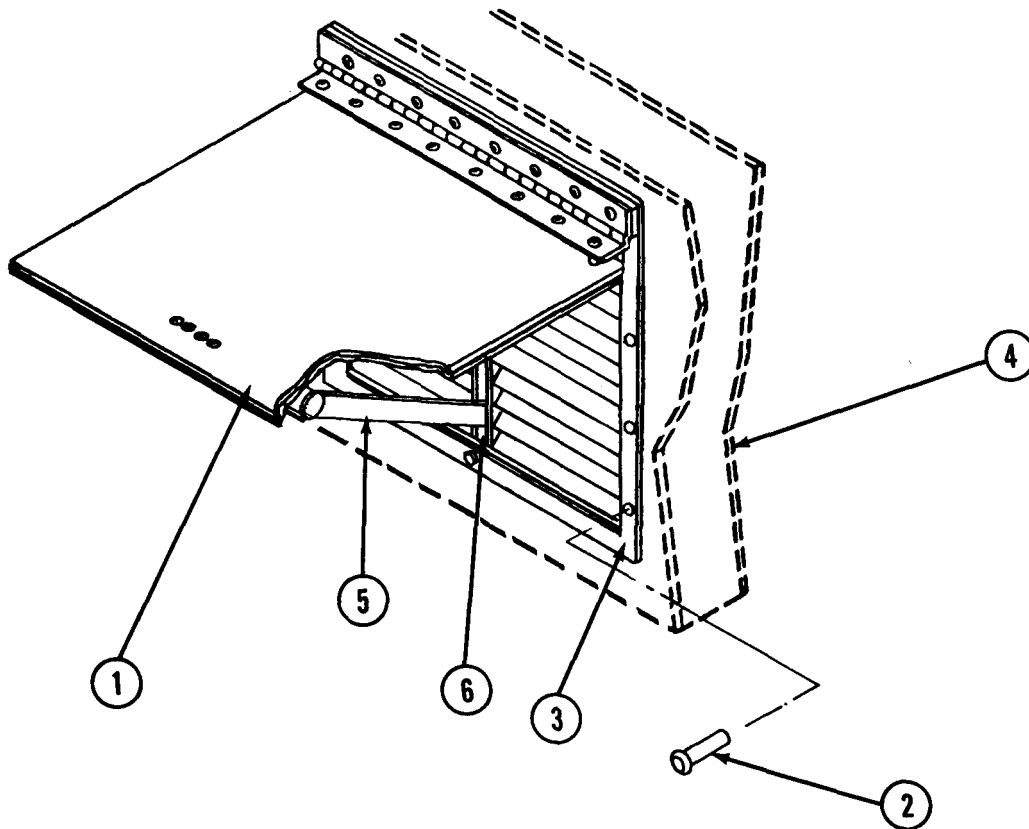

1. Open exhaust fan door (1).
2. Drill out seven rivets (2) securing external exhaust fan housing assembly (3) to Section body (4).
3. Pull brace (5) through vent (6) and remove external exhaust fan housing assembly (3) from Section body (4).

WARNING

CHEMICAL HAZARD. Use rubber cement thinner in a well-ventilated area. Failure to do so may result in damage to respiratory system. Wear gloves and goggles to prevent injuries to skin and eyes.

4. Scrape silicone compound from Section body. Clean off residue with rubber cement thinner.

2-12. REPLACE EXTERNAL EXHAUST FAN HOUSING ASSEMBLY (CONT)

INSTALLATION

WARNING

CHEMICAL HAZARD. Use silicone compound in a well-ventilated area. Silicone compound is harmful to eyes and skin. In case of contact with eyes, immediately flush eyes with water for 15 minutes, then seek medical help. In case of contact with skin, wipe off with dry cloth, then wash with soap and water.

1. Apply silicone compound to outer edges of external exhaust fan housing assembly (3).
2. Install external exhaust fan housing assembly (3) onto Section body (4) with rivets (2). Wipe off excess silicone compound around edge of housing.
3. Push brace (5) through slot in vent (6).
4. If necessary, paint external exhaust fan housing assembly in accordance with TM 43-0139.

2-13. REPAIR EXTERNAL EXHAUST FAN HOUSING ASSEMBLY

External exhaust fan housing assembly is repaired by replacing:

- a. Exhaust fan door
- b. Gaskets

EXHAUST FAN DOOR

INITIAL SETUP

Tools

Light machine repair tool kit (appendix B, section III, item 11)
Portable electric drill
Twist drill set
Rivet gun (appendix B, section III, item 10)
Scraping knife (appendix B, section III, item 9)
Extension cord
Folding ladder

Materials/Parts

Exhaust fan door, 13225E3248
Rivet, MS20601-B8W6
Rivet, MS20470-AD37
Rivet, MS20470-AD38
Housing gasket, 13225E3266-1 (2 required)
Housing gasket, 13225E3266-2 (2 required)
Adhesive (appendix C, item 1)

2-13. REPAIR EXTERNAL EXHAUST FAN MOUSING ASSEMBLY (CONT)

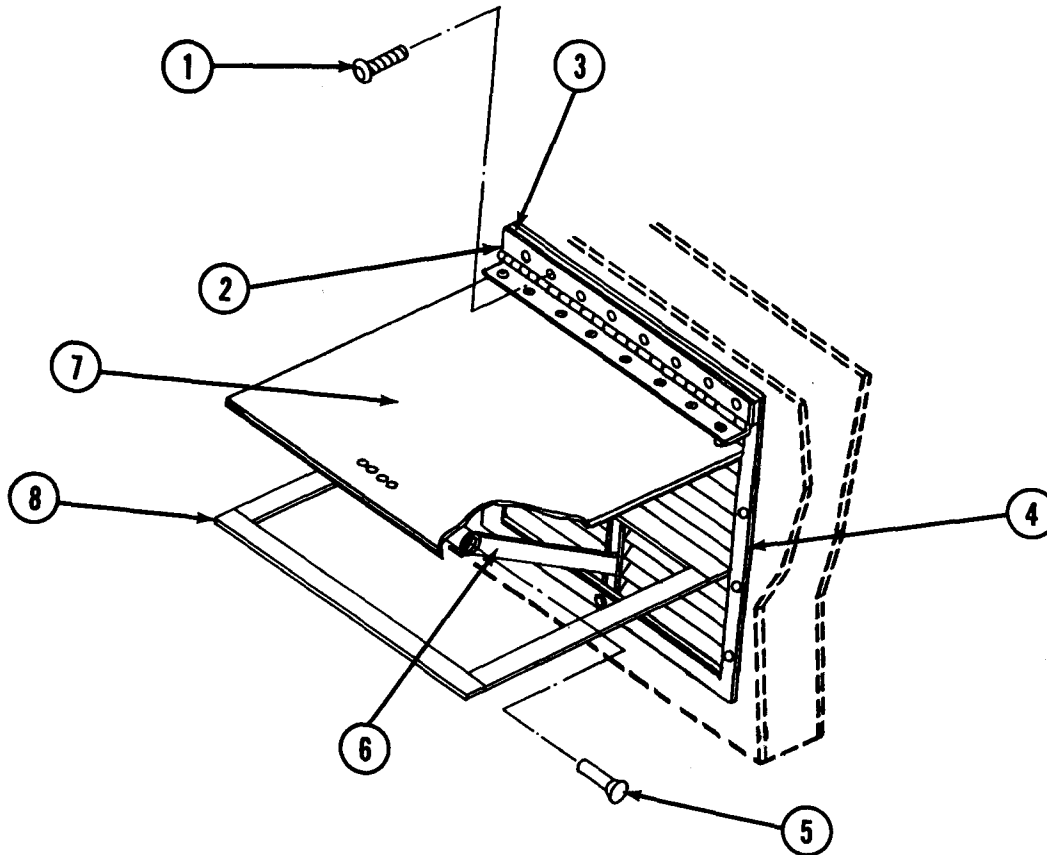

1. Remove external exhaust fan housing assembly (para 2-12).
2. Drill out rivets (1) securing hinge (2) and spacer (3) to housing assembly (4).
3. Drill out rivet (5) securing brace (6) to exhaust fan door (7).

WARNING

CHEMICAL HAZARD. Use adhesive in a well-ventilated area. Adhesive is harmful to eyes and skin. In case of contact with eyes, immediately flush eyes with water for 15 minutes, then seek medical help. In case of contact with skin, wipe off with dry cloth, then wash with soap and water.

4. Apply adhesive around edges of new exhaust fan door (7) and install four gaskets (8).

2-13. REPAIR EXTERNAL EXHAUST FAN HOUSING ASSEMBLY (CONT)

5. Install brace (6) to new exhaust fan door (7) with rivet (5).
6. Align spacer (3) and hinge (2) with housing assembly (4) and install with rivets (1).
7. Install external exhaust fan housing assembly (para 2-12).

GASKETS

INITIAL SETUP

Tools

Scraping knife (appendix B, section III, item 9)
Folding ladder

Materials/Parts

Housing gasket, 13225E3266-1 (2 required)
Housing gasket, 13225E3266-2 (2 required)
Adhesive (appendix C, item 1)
Rubber cement thinner (appendix C, item 33)
Rag (appendix C, item 24)

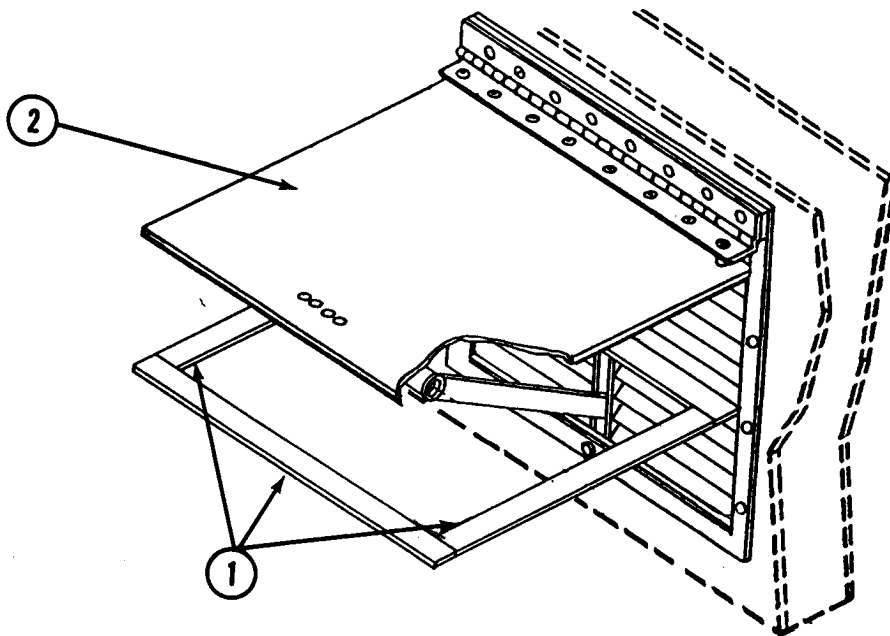

2-13. REPAIR EXTERNAL EXHAUST FAN HOUSING ASSEMBLY (CONT)

1. Scrape gasket sections (1) from exhaust fan door (2).

WARNING

CHEMICAL HAZARD. Use rubber cement thinner in a well-ventilated area. Failure to do so may result in damage to respiratory system. Wear gloves and goggles to prevent injuries to skin and eyes.

2. Remove adhesive from exhaust fan door (2) with rubber cement thinner.

WARNING

CHEMICAL HAZARD. Use adhesive in a well-ventilated area. Adhesive is harmful to eyes and skin. In case of contact with eyes, immediately flush eyes with water for 15 minutes, then seek medical help. In case of contact with skin, wipe off with dry cloth, then wash with soap and water.

3. Apply adhesive around edges of exhaust fan door (2) and install gasket sections (1).

2-14. REPLACE REMOVABLE FLOOR SECTION CARRIER BRACKETS

This task covers: a. Removal b. Installation

INITIAL SETUPTools

Light machine repair tool kit (appendix B, section III, item 11)
 Portable electric drill
 Twist drill set
 Rivet gun (appendix B, section III, item 10)

Materials/Parts

Carrier bracket, 13226E7976-1
 Carrier bracket, 13226E7976-2
 Rivet, MS20600-MP4W6
 Rivet, MS20600-AD6W4

Equipment Conditions

Curbside expanding side expanded with folding floor in down position
 (TM 5-3610-287-10, para 2-6)

2-14. REPLACE REMOVABLE FLOOR SECTION CARRIER BRACKETS (CONT)

REMOVAL

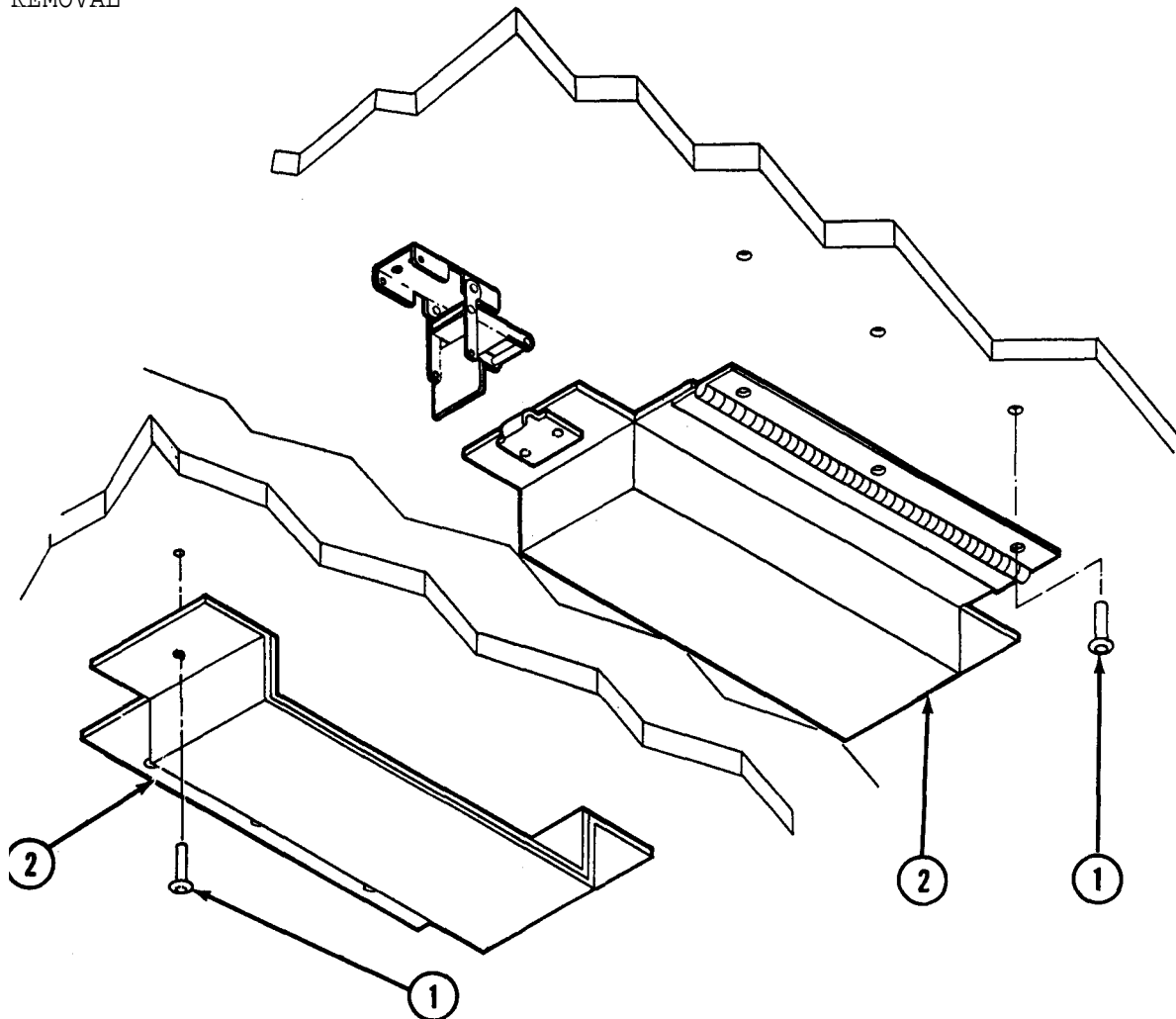

1. On Section exterior beneath curbside expanding side, drill out rivets (1) securing each carrier bracket (2) to folding floor.
2. Remove carrier bracket.

INSTALLATION

Position new carrier bracket (2) on folding floor and secure with rivets (1).

2-15. REPAIR REMOVABLE FLOOR SECTION CARRIER BRACKETS

Removable floor section carrier brackets are repaired by replacing:
 a. Rubber pad b. Latch and strike

RUBBER PAD

INITIAL SETUP

Tools

Scraping knife (appendix B, section III, item 9)

Materials/Parts

- Rubber pad, 13226E7976-1-2
- Rubber pad, 13226E7976-1-3
- Rag (appendix C, item 24)
- Adhesive (appendix C, item 1)
- Rubber cement thinner (appendix C, item 33)

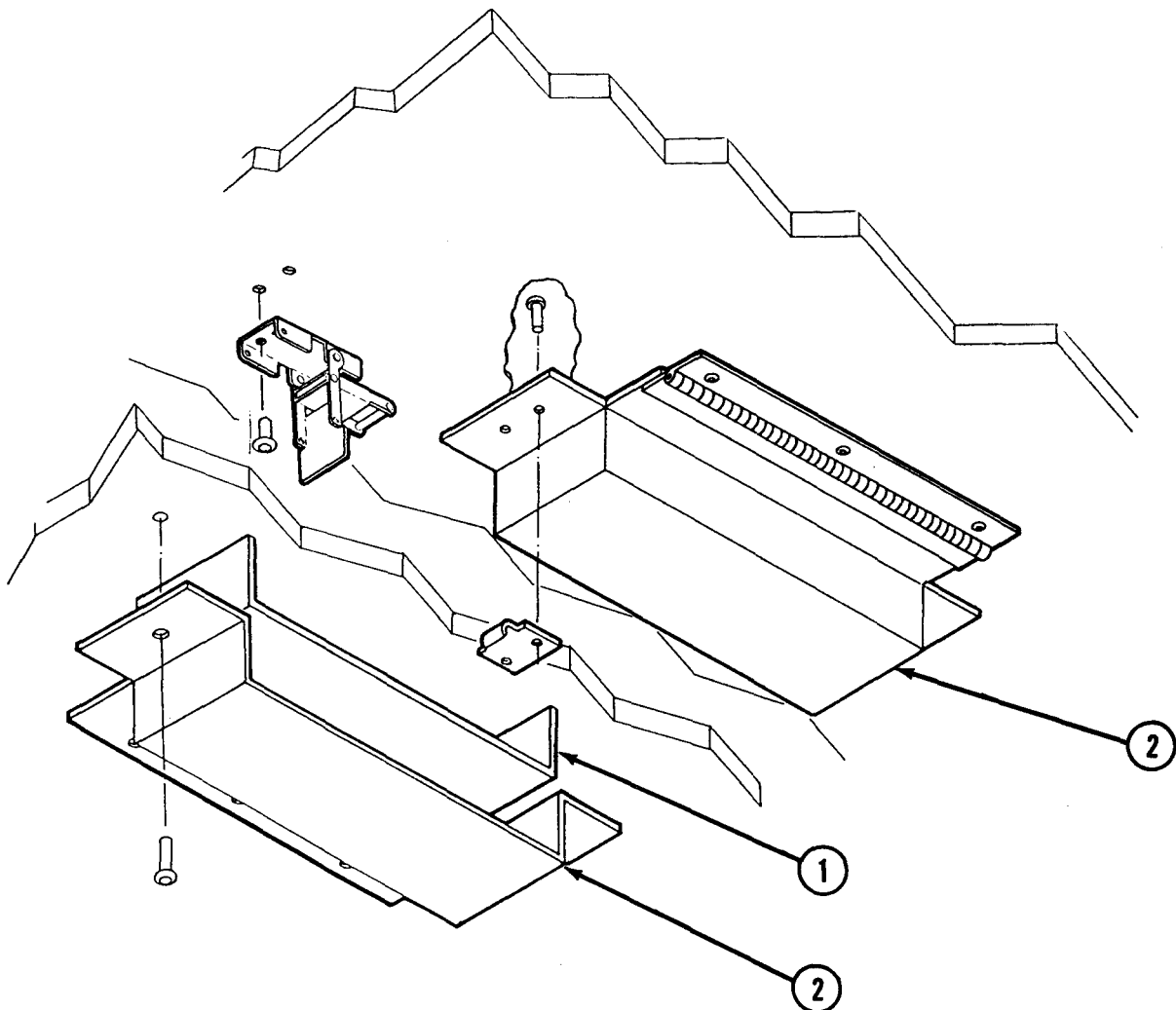

2-15. REPAIR REMOVABLE FLOOR SECTION CARRIER BRACKETS (CONT)

1. Scrape old rubber pads (1) from carrier bracket (2).

WARNING

CHEMICAL HAZARD. Use rubber cement thinner in a well-ventilated area. Failure to do so may result in damage to respiratory system. Wear gloves and goggles to prevent injuries to skin and eyes.

2. Clean adhesive from carrier bracket (2) with rubber cement thinner.

WARNING

CHEMICAL HAZARD. Use adhesive in a well-ventilated area. Adhesive is harmful to eyes and skin. In case of contact with eyes, immediately flush eyes with water for 15 minutes, then seek medical help. In case of contact with skin, wipe off with dry cloth, then wash with soap and water.

3. Apply adhesive to carrier bracket (2) and install new rubber pads (1).

LATCH AND STRIKE

INITIAL SETUP

Tools

Light machine repair tool kit (appendix B, section III, item 11)
Portable electric drill
Twist drill set
Rivet gun (appendix B, section III, item 10)

Materials/Parts

Latch and strike, 13200E2799
Rivets, MS20600-MP4W6
Rivets, MS20600-AD6W4

2-15. REPAIR REMOVABLE FLOOR SECTION CARRIER BRACKETS (CONT)

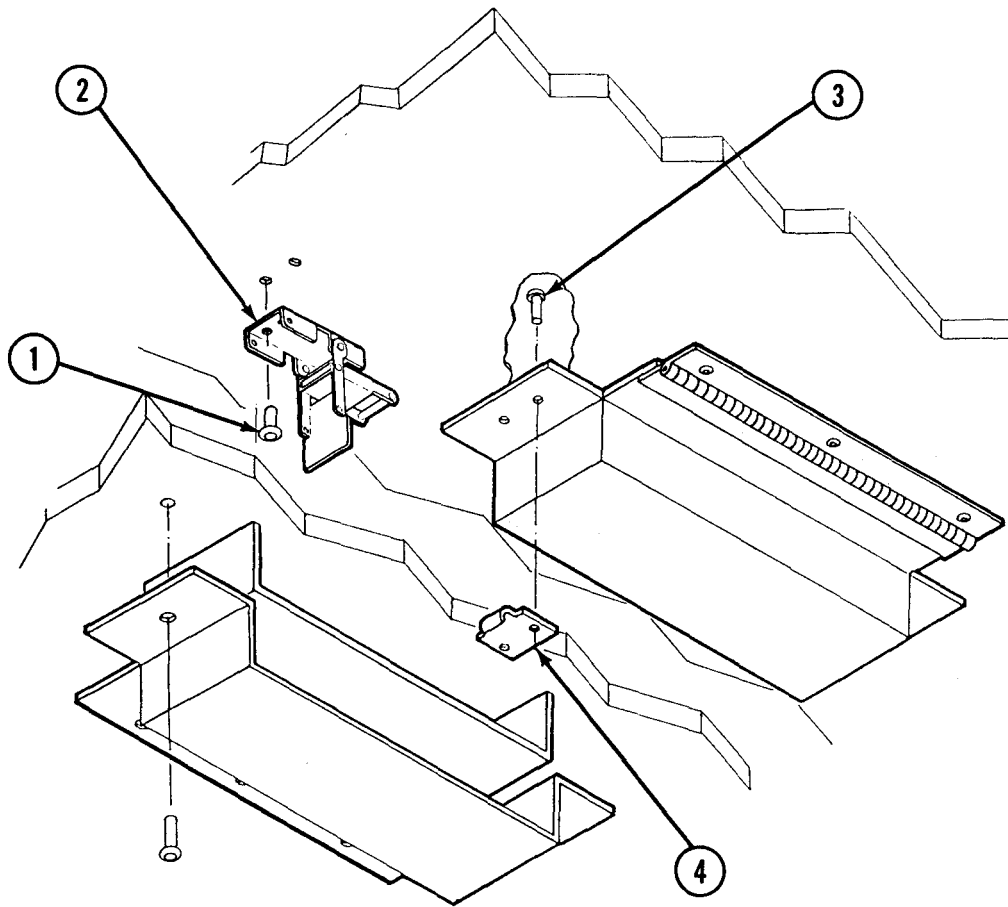

1. Drill out rivets (1) securing latch (2).
2. Drill out rivets (3) securing strike (4).
3. Position latch (2) and secure with rivets (1).
4. Position strike (4) and secure with rivets (3).

2-16. REPAIRY CADDY ASSEMBLY

Tool caddy assembly is repaired by replacing: Tool caddy

TOOL CADDY

INITIAL SETUP

Tools

Light machine repair tool kit (appendix B, section III, item 11)
Cross-tip screwdriver
Socket wrench set

Materials/Parts

Tool caddy, 13226E7905

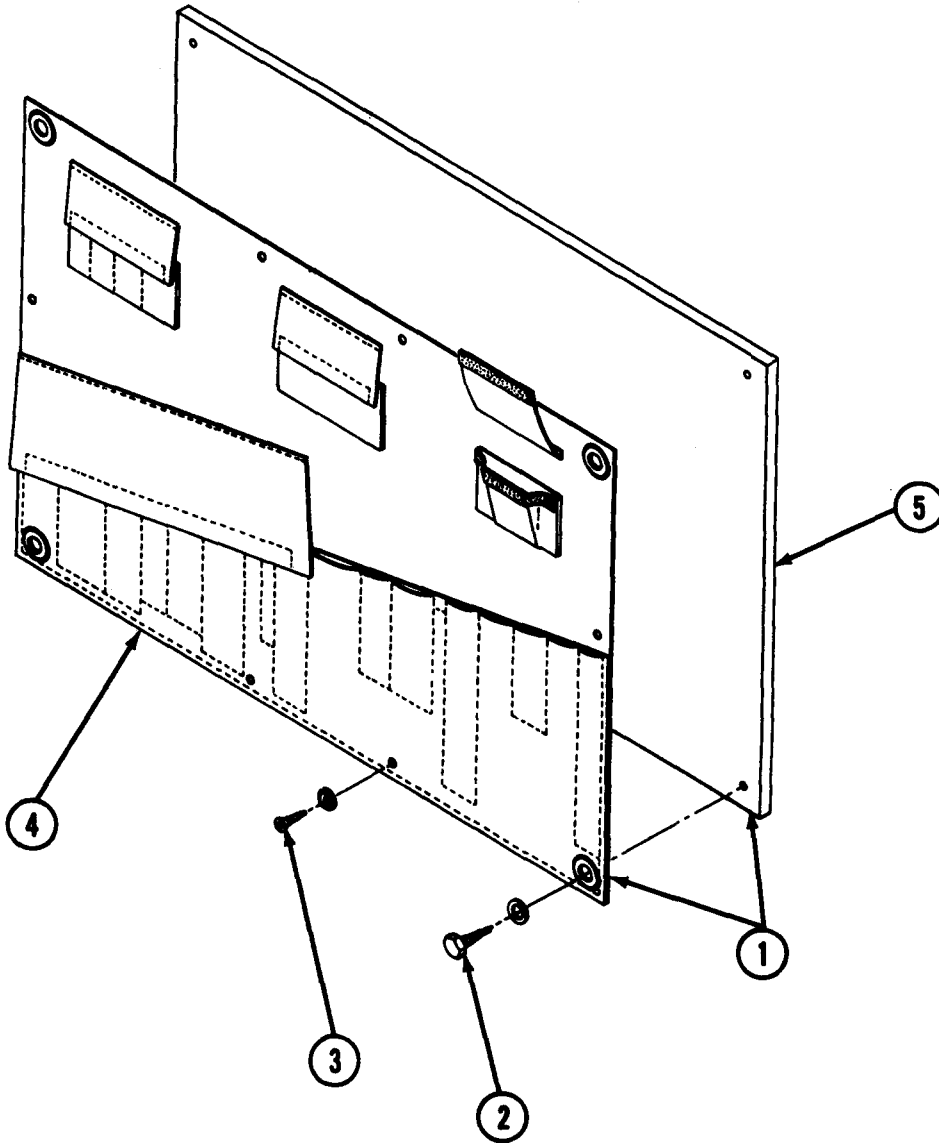

2-16. REPAIR TOOL CADDY ASSEMBLY (CONT)

1. Remove tools from tool caddy assembly (1).
2. Remove lag bolts (2) and flatwashers securing tool caddy assembly (1) to Section wall.
3. Remove screws (3) and cupped washers securing tool caddy (4) to mounting board, (5).
4. Install new tool caddy (4) on mounting board (5) with screws (3) and cupped washers.

CAUTION

Do not overtighten lag bolts. Failure to observe this caution may damage Section walls.

5. Install tool caddy assembly (1) with lag bolts (2) and flatwashers.
6. Replace tools in tool caddy assembly.

2-17. REPLACE STRAP AND BUCKLE ASSEMBLY

This task covers: a. Removal b. Installation

INITIAL SETUP

Tools

Light machine repair tool kit (appendix B, section III, item 11)
Cross-tip screwdriver
Portable electric drill
Twist drill set
Rivet gun (appendix B, section III, item 10)

Materials/Parts

Strap and buckle assembly, 13226E7833-1
Strap, 13226E7834-1
Loop strap fastener, MS51939-1
Blind rivet, MS20600-AD6W4

2-17. REPLACE STRAP AND BUCKLE ASSEMBLY (CONT)

REMOVAL

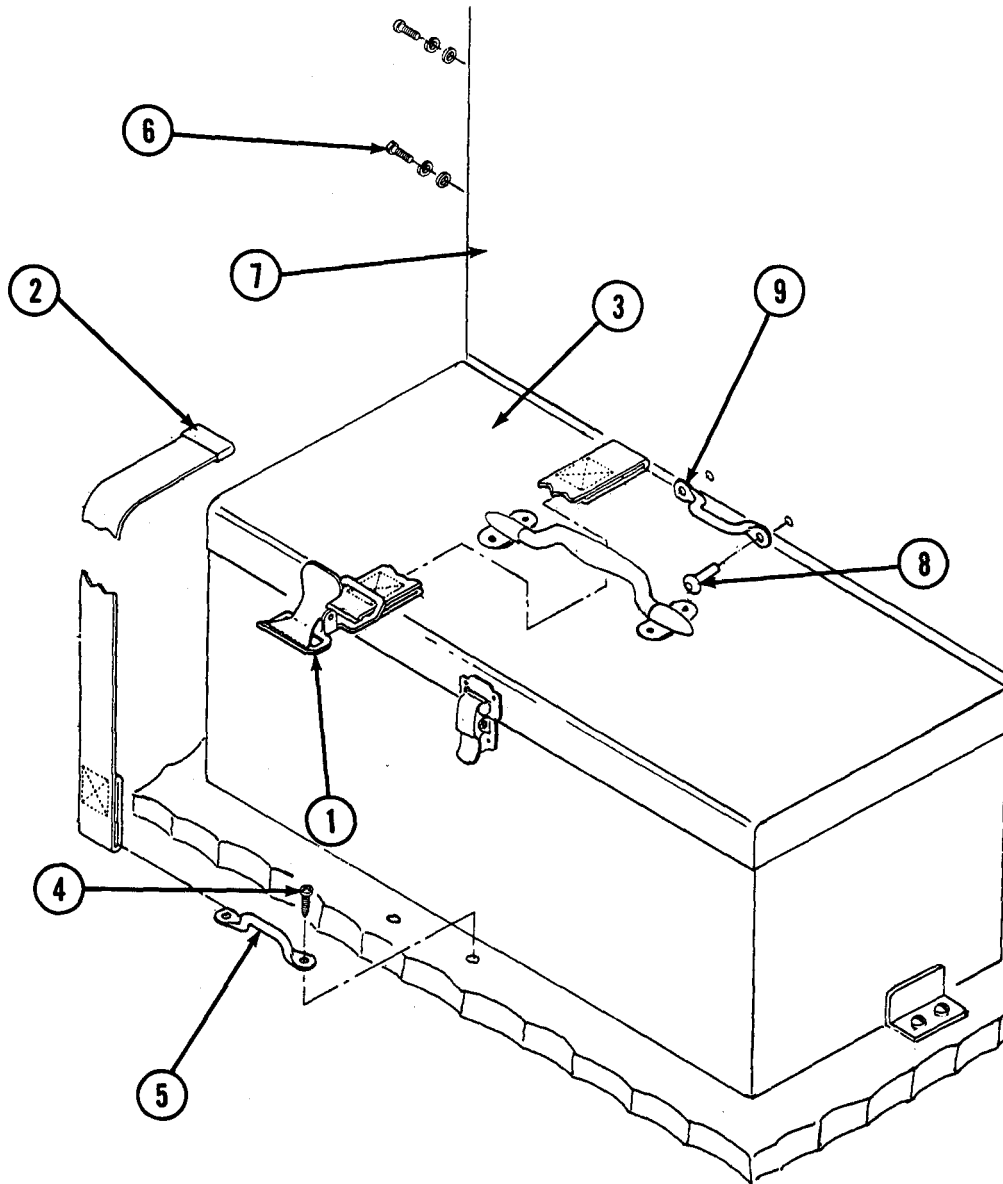

1. Disconnect strap and buckle assembly (1) from strap (2).
2. Remove tool box (3).
3. Remove screws (4) securing loop strap fastener (5) to floor. Remove strap (2) from fastener (5).

2-17. REPLACE STRAP AND BUCKLE ASSEMBLY (CONT)**WARNING**

- **ELECTRICAL HAZARD.** Turn off main power switch and disconnect main power cable before removing power entry panel cover. Failure to do so could result in death or serious injury.
 - **HIGH VOLTAGE.** Do not drill out rivets until power entry panel cover is removed. Electrical power cords carrying high voltage are directly behind cover, and could contact drill bit, causing death or serious injury.
4. Set MAIN POWER switch to OFF and disconnect main power cable.
 5. Remove screws (6), lockwashers, flatwashers, and power entry panel cover (7).
 6. Drill out rivets (8) securing loop strap fastener (9) to cover (7).
 7. Remove strap and buckle assembly (1) from fastener (9).

INSTALLATION

1. Thread loop strap fastener (9) through strap and buckle assembly (1).
2. Install loop strap fastener (9) on cover (7) with rivets (8).
3. Install power entry panel cover (7) with screws (6).

WARNING

ELECTRICAL HAZARD. Do not connect power cable to Section before grounding. Failure to observe this warning may result in death or serious injury.

4. Connect main power cable and set MAIN POWER switch to ON.
5. Thread loop strap fastener (5) through strap (2).
6. Install fastener (5) with screws (4).
7. Secure tool box (3) to floor with strap and buckle assembly (1) and strap (2).

2-18. REPLACE FIRST AID KIT

This task covers: a. Removal b. Installation

INITIAL SETUP

Tools

Light machine repair tool kit (appendix B, section III, item 11)
Cross-tip screwdriver
Portable electric drill
Twist drill set
Rivet gun (appendix B, section III, item 10)

Materials/Parts

First aid kit, 13226E4497
Blind rivet, MS51861-3 (2 required)

REMOVAL

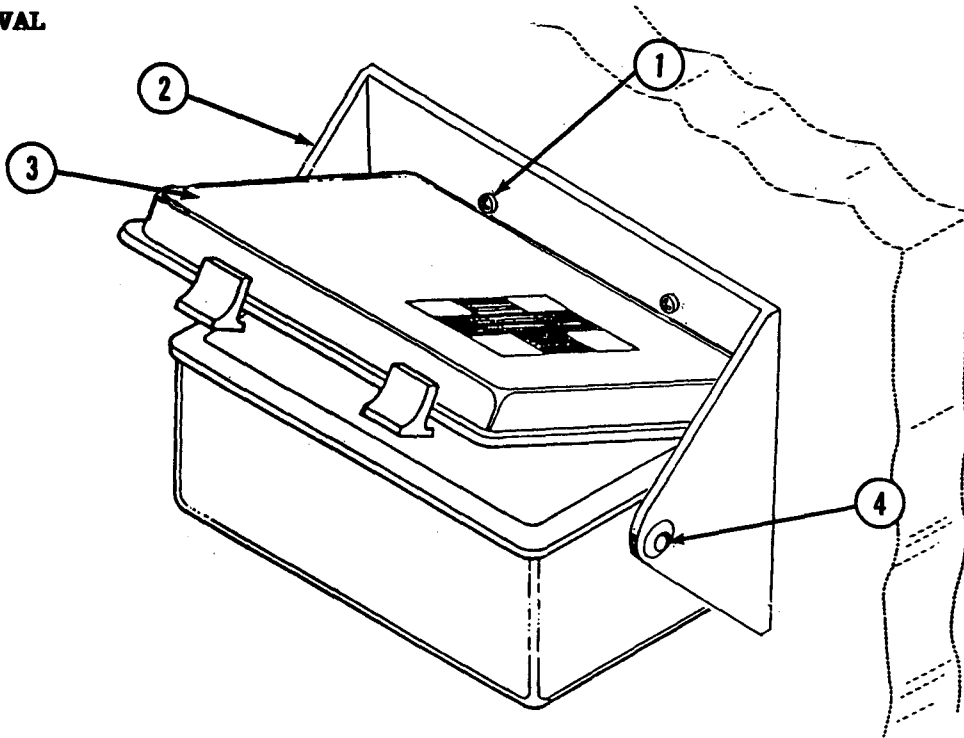

1. Remove four screws (1) securing first aid kit mounting bracket (2) to wall.
2. Remove first aid kit mounting bracket (2) from first aid kit (3) by drilling out two rivets (4).

2-18. REPLACE FIRST AID KIT (CONT)

INSTALLATION

1. Install first aid kit (3) on first aid kit mounting bracket (2) with rivets (4).
2. Install first aid kit mounting bracket (2) and first aid kit (3) on wall with screws (1).

2-19. REPLACE FIRE EXTINGUISHER

This task covers: a. Removal b. Installation

INITIAL SETUP

Tools

Light machine repair tool kit (appendix B, section III, item 11)
Cross-tip screwdriver
Portable electric drill
Twist drill set

Materials/Parts

Fire extinguisher, 13226E7974
Lead pencil (appendix C, item 13)

NOTE

This task is performed only when new fire extinguisher will not fit original mounting bracket.

2-19. REPLACE FIRE EXTINGUISHER (CONT)

REMOVAL

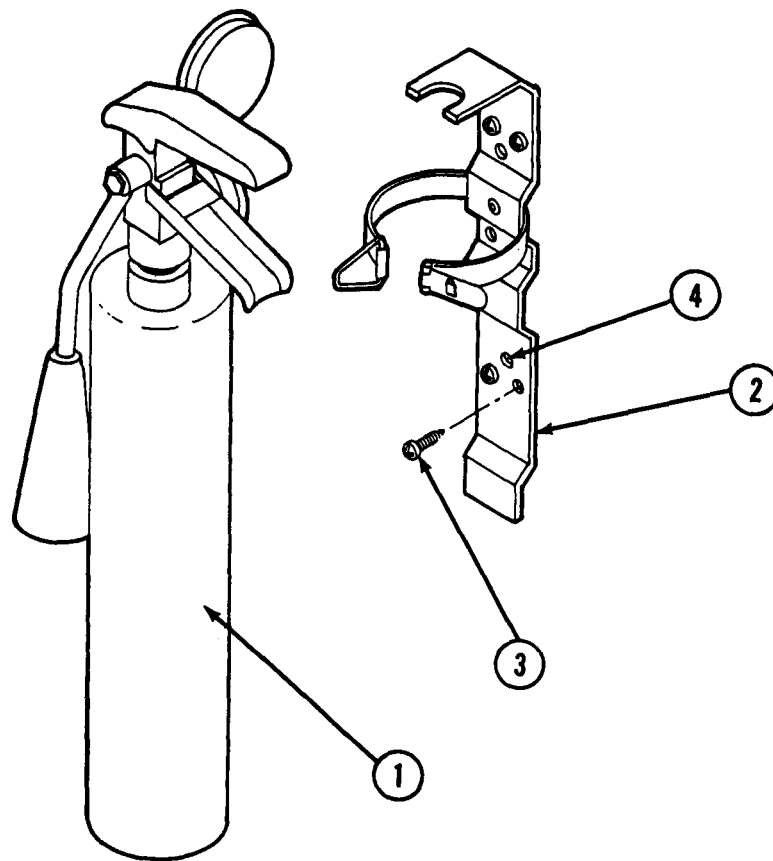

1. Remove fire extinguisher (1) from mounting bracket (2).
2. Remove screws (3) securing mounting bracket (2) to wall.

INSTALLATION

1. Position new mounting bracket (2) on wall. If necessary, mark holes (4) for drilling.
2. Drill holes (4) for mounting screws (3).
3. Install new mounting bracket (2) to wall with mounting screws (3).
4. Install new fire extinguisher (1) to mounting bracket (2).

2-20. REPLACE EMERGENCY LIGHT SET

This task covers: a. Removal b. Installation

INITIAL SETUP

Tools

- Light machine repair tool kit (appendix B, section III, item 11)
- Socket wrench set
- Cross-tip screwdriver (2 sizes required)
- Flat-tip screwdriver

Materials/Parts

Emergency light set, 13226E7911

REMOVAL

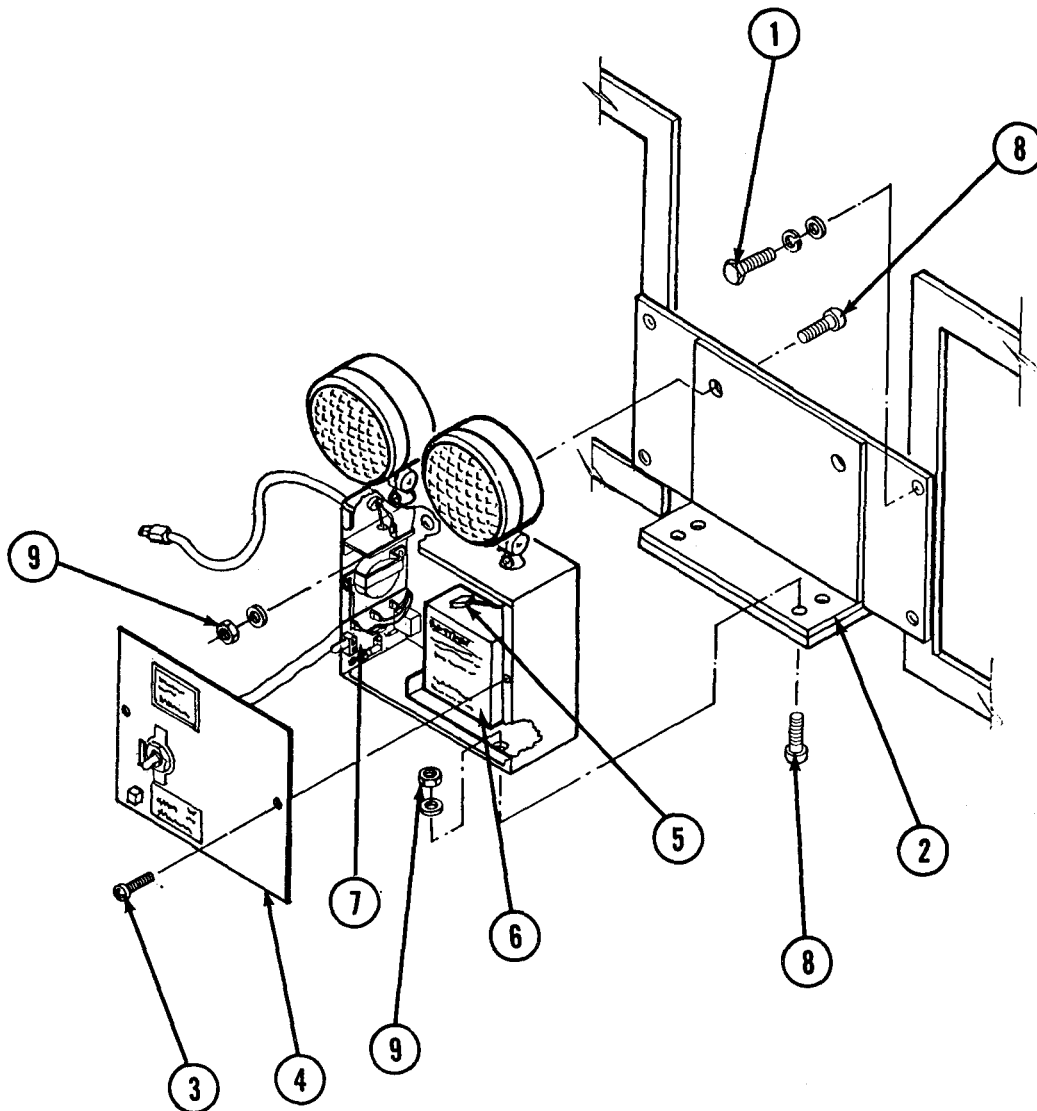

2-20. REPLACE EMERGENCY LIGHT SET (CONT)

WARNING

ELECTRICAL HAZARD. Unplug emergency light power cord before replacing emergency light. Failure to do so may result in death or serious injury.

1. Turn off emergency light and unplug emergency light power cord.
2. Remove hex bolts (1), lockwashers, and flatwashers securing mounting bracket (2) to wall. Remove emergency light assembly from wall.
3. Remove screws (3) securing cover (4) to emergency light set.
4. Disconnect leads (5) from battery (6) and remove battery from emergency light set.
5. Remove three screws securing circuit card (7) to emergency light set. Allow circuit card (7) to hang by wires.
6. Remove six screws (8), lockwashers, and nuts (9) securing mounting bracket (2) to emergency light set. Remove mounting bracket (2).

INSTALLATION

1. Remove two screws (3) securing cover (4) to new emergency light set.
2. Disconnect leads (5) from battery (6) and remove battery from new emergency light set.
3. Remove three screws securing circuit card (7) to emergency light set. Allow circuit card to hang by wires.
4. Install mounting bracket (2) with six screws (8), lockwashers, and nuts (9).
5. Secure circuit card (7) to emergency light set with three screws.
6. Install battery (6) in emergency light set and attach leads (5).
7. Install cover (4) with screws (3).
8. Install emergency light assembly with hex bolts (1), flatwashers, and lockwashers.
9. Plug in power cord.
10. To test operate, set toggle switch to ON and operate test switch. Emergency lamps should light and indicator lamp should go out.

2-21. REPAIR EMERGENCY LIGHT SET

Emergency light set is repaired by replacing: a. Toggle switch
 b. Light bulb c. Battery d. Printed circuit board e. Transformer

TOGGLE SWITCH

INITIAL SETUP

Tools

- Light machine repair tool kit (appendix B, section III, item 11)
- Flat-tip screwdriver
- Pliers
- Soldering iron
- Solder

Materials/Parts

- Toggle switch, MS27735-11
- Masking tape (appendix C, item 29)
- Lead pencil (appendix C, item 13)

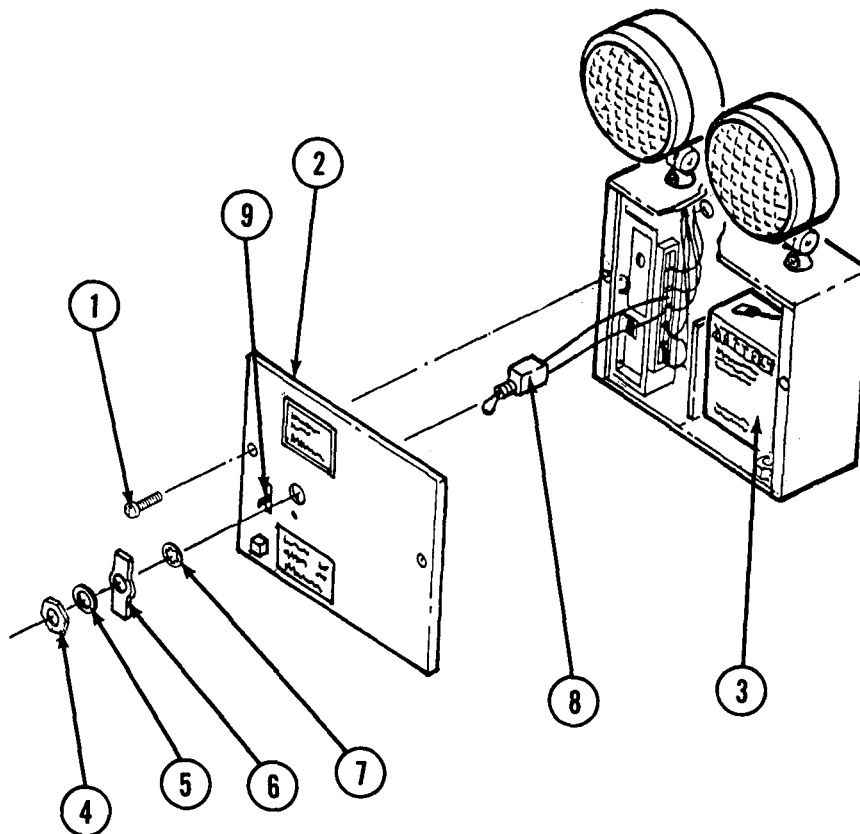

2-21. REPAIR EMEERGENCY LIGHT SET (CONT)

WARNING

ELECTRICAL HAZARD. Unplug emergency light power cord before replacing toggle switch. Failure to do so may result in death or serious injury.

1. Turn off emergency light and unplug power cord.
2. Remove screws (1) securing emergency light cover (2) to emergency light.
3. Disconnect positive (red) lead from battery (3).
4. Remove hex nut (4), flatwasher (5), ON/OFF plate (6), and key (7) securing toggle switch (8) to emergency light cover.
5. Tag and desolder two wires from switch terminals. Remove toggle switch (8).
6. Solder two wires to terminals of new toggle switch (8).
7. Install toggle switch on emergency light cover with key (7), ON/OFF plate (6), flatwasher (5), and hex nut (4).
8. Connect positive (red) lead to battery (3).
9. Install emergency light cover (2) on emergency light with screws (1).
- 10 1 Plug in emergency light power cord and turn on emergency light.
11. Push TEST button (9) down to test operate.

LIGHT BULB

INITIAL SETUP

Tools

Light machine repair tool kit (appendix B, section III, item 11)
Flat-tip. screwdriver

Materials/Parts

Light bulb, 1130

2-21. REPAIR EMERGENCY LIGHT SET (CONT)

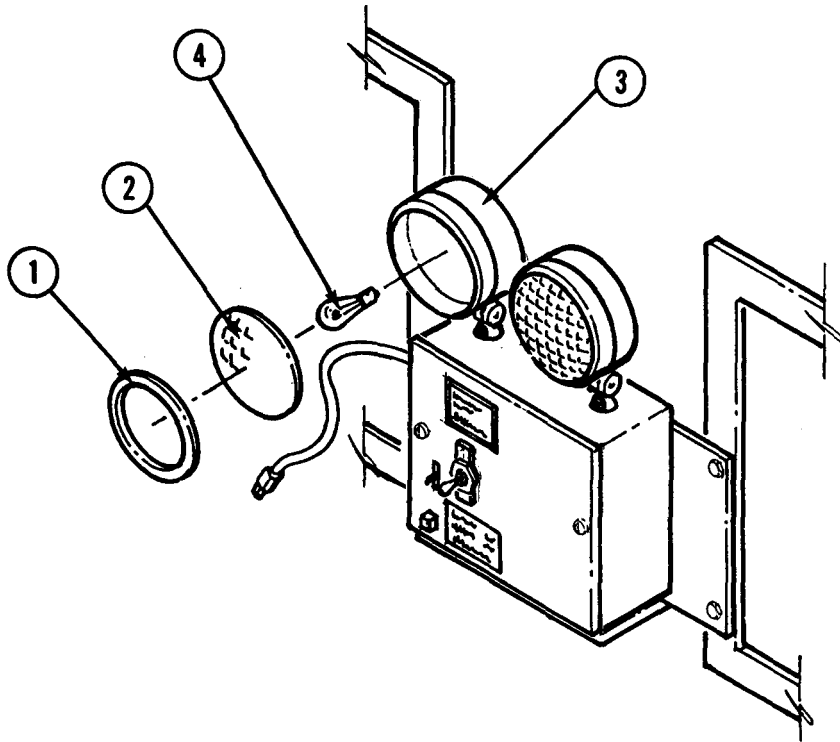
WARNING

ELECTRICAL HAZARD. Unplug emergency light power cord before replacing light bulb. Failure to do so may result in death or serious injury.

1. Turn off emergency light and unplug power cord.
2. Insert screwdriver in notch on plastic retaining ring (1) and remove.
3. Remove emergency lamp lens (2) from lamp holder (3).
4. Push in and turn emergency light bulb (4) to remove from socket.
5. Install new emergency light bulb (4) in socket. Push in and turn to secure.
6. Install emergency lamp lens (2) in lamp holder (3).
7. Install plastic retaining ring (1).

2-21. REPAIR EMERGENCY LIGHT SET (CONT)

BATTERY

INITIAL SETUP

Tools

- Light machine repair tool kit (appendix B, section III, item 11)
- Flat-tip screwdriver

Materials/Parts

- Battery, CE1-5AG

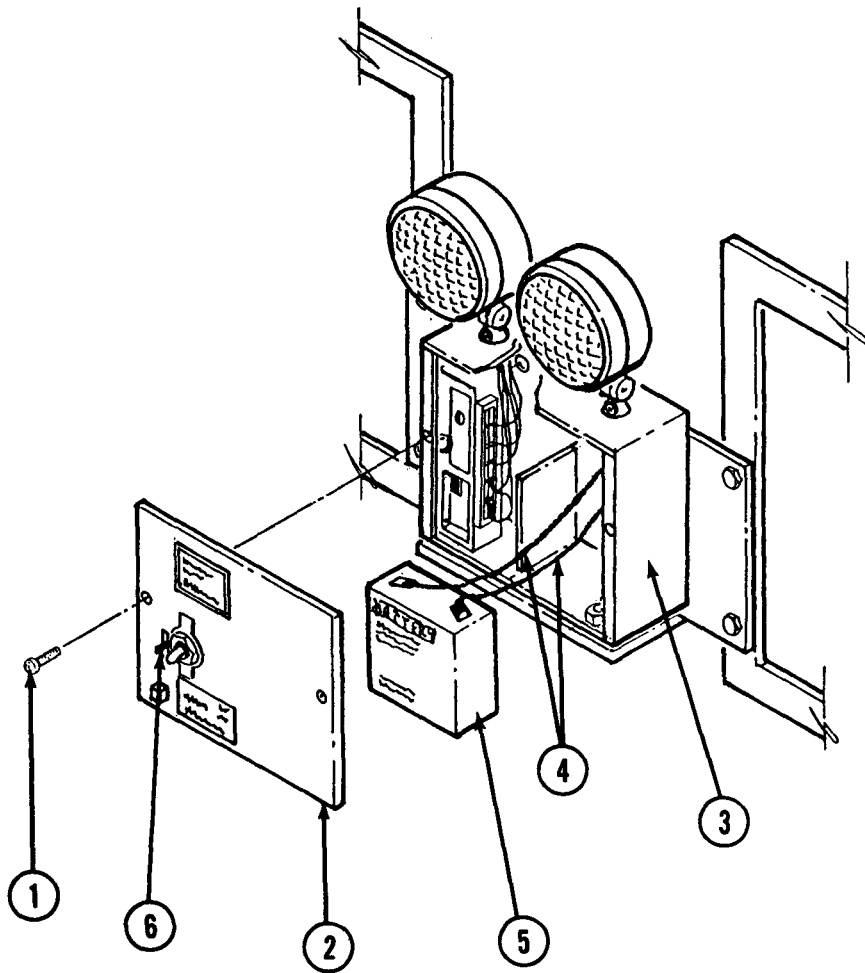

2-21. REPAIR EMERGENCY LIGHT SET (CONT)**WARNING**

ELECTRICAL HAZARD. Unplug emergency light power cord before replacing battery. Failure to do so may result in death or serious injury.

1. Turn off emergency light and unplug power cord.
2. Remove two screws (1) securing emergency light cover (2) to emergency light set (3).
3. Remove positive (red) and negative (black) wires (4) from battery posts.
4. Tilt top of battery (5) out and remove from emergency light set (3).
5. Install new battery (5) in emergency light set (3).
6. Connect positive (red) wire and negative (black) wire (4) to battery posts, observing polarity.
7. Install emergency light cover (2) with screws (1).
8. Plug in emergency light power cord and set toggle switch to ON.
9. Push TEST button (6) down to test battery operation.

PRINTED CIRCUIT BOARD**INITIAL SETUP****Tools**

Light machine repair tool kit (appendix B, section III, item 11)
 Cross-tip screwdriver
 Flat-tip screwdriver
 Pliers
 Soldering iron
 Solder

Materials/Parts

Printed circuit board, GSA78
 Masking tape (appendix C, item 29)
 Lead pencil (appendix C, item 13)

2-21. REPAIR EMERGENCY LIGHT SET (CONT)

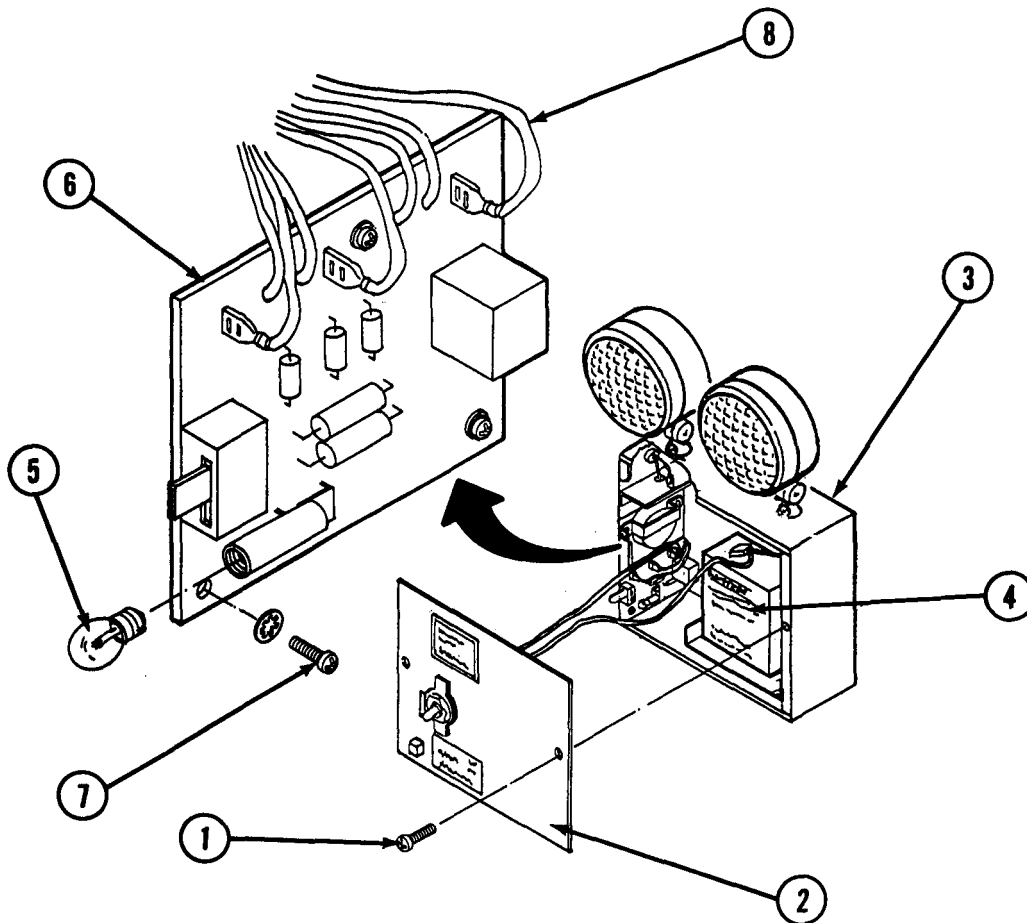

WARNING

ELECTRICAL HAZARD. Unplug emergency light power cord before replacing circuit board. Failure to do so may result in death or serious injury.

1. Turn off emergency light and unplug power cord.
2. Remove screws (1) securing emergency light cover (2) to emergency light set (3).
3. Disconnect both wires from battery (4) and remove battery (4).
4. Remove bulb (5) from circuit board (6).

2-21. REPAIR EMERGENCY LIGHT SET (CONT)

5. Remove screws (7) and starwashers. Partially remove circuit board (6).
6. Tag and remove wires (8). Remove circuit board (6).
7. Install wires (8) on new circuit board (6).
8. Install circuit board (6) with screws (7) and starwashers.
9. Install bulb (5) on circuit board (6).
10. Install battery (4) and connect wires, observing polarity.
11. Install emergency light cover (2) on emergency light set (3) with screws (1).
12. Plug in emergency light power cord and turn on emergency light set.
13. Push TEST button down to test operate.

TRANSFORMER

INITIAL SETUPTools

Light machine repair tool kit (appendix B, section III, item 11)
 Flat-tip screwdriver
 Portable electric drill
 Twist drill set
 Pliers
 Rivet gun (appendix B, section III, item 10)

Materials/Parts

Transformer, 208P5
 Rivet, MS20600A4W4 (2 required)
 Wire nut, 2978 (2 required)
 Masking tape (appendix C, item 29)
 Lead pencil (appendix C, item 13)

2-21. REPAIR EMERGENCY LIGHT SET (CONT)

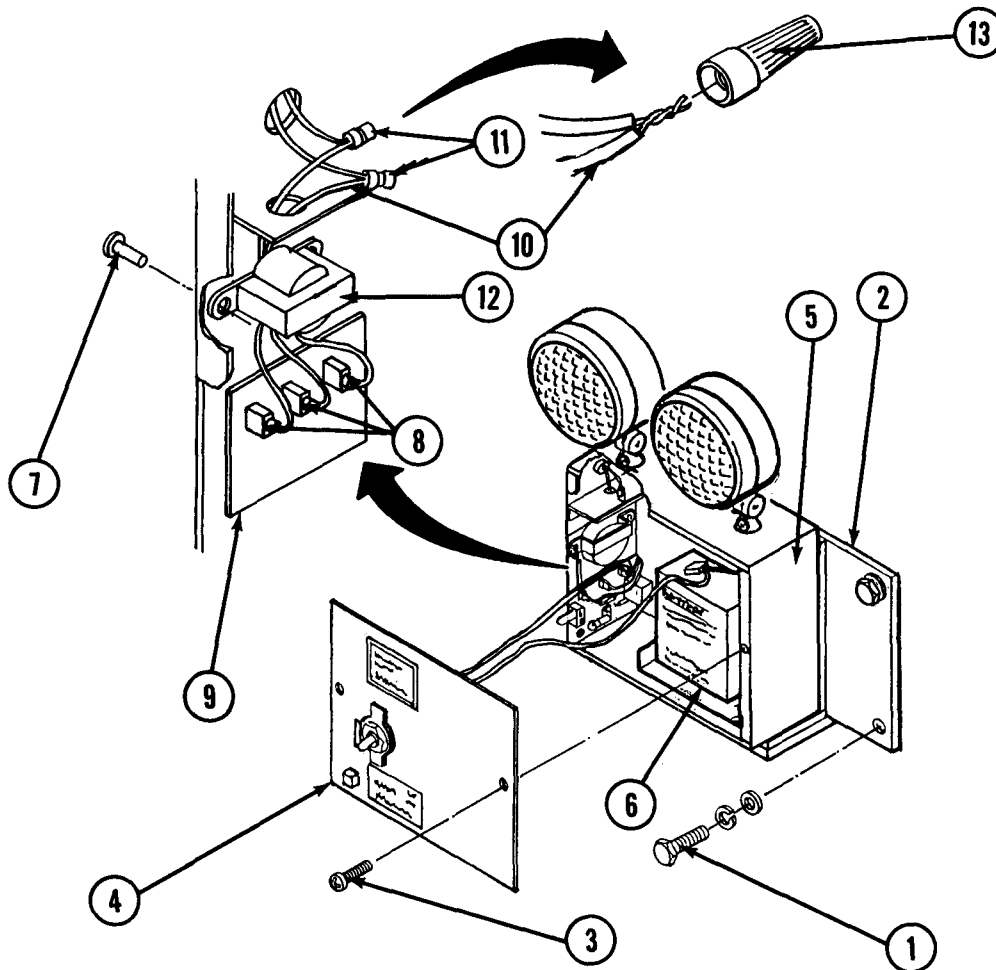

WARNING

ELECTRICAL HAZARD. Unplug emergency light power cord before replacing transformer. Failure to do so may result in death or serious injury.

1. Turn off emergency light and unplug power cord.
2. Remove hex bolts (1), lockwashers, and flatwashers. Remove emergency light assembly (2) from wall.
3. Remove screws (3) securing emergency light cover (4) to emergency light set (5).
4. Disconnect both wires from battery (6) and remove battery.

2-21. REPAIR EMERGENCY LIGHT SET (CONT)

5. Drill out rivets (7).
6. Tag and remove wires (8) from circuit board (9).
7. Tag and cut wires (10) above connectors (11). Remove transformer (12).
8. Install new transformer (12) with rivets (7).
9. Connect wires (10) with new wire nuts (13).
10. Connect wires (8) to circuit board (9).
11. Install battery (6) and connect wires, observing polarity.
12. Install emergency light cover (4) on emergency light set (5) with screws (3).
13. Install emergency light assembly (2) on wall with hex bolts (1), lockwashers, and flatwashers.
14. Plug in emergency light power cord and turn on emergency light set.
15. Push TEST button down to test operate.

2-22. REPLACE MIRROR AND SAFETY CHAIN

This task covers: a. Removal b. Installation

INITIAL SETUP

Tools

Light machine repair tool kit (appendix B, section III, item 11)
 Flat-tip screwdriver
 Cross-tip screwdriver

Materials/Parts

Mirror, 13226E7937
 Bead chain coupling end, NAS1201C6B
 Bead chain, HAS1201C6-12A

2-22. REPLACE MIRROR AND SAFETY CHAIN (CONT)

REMOVAL

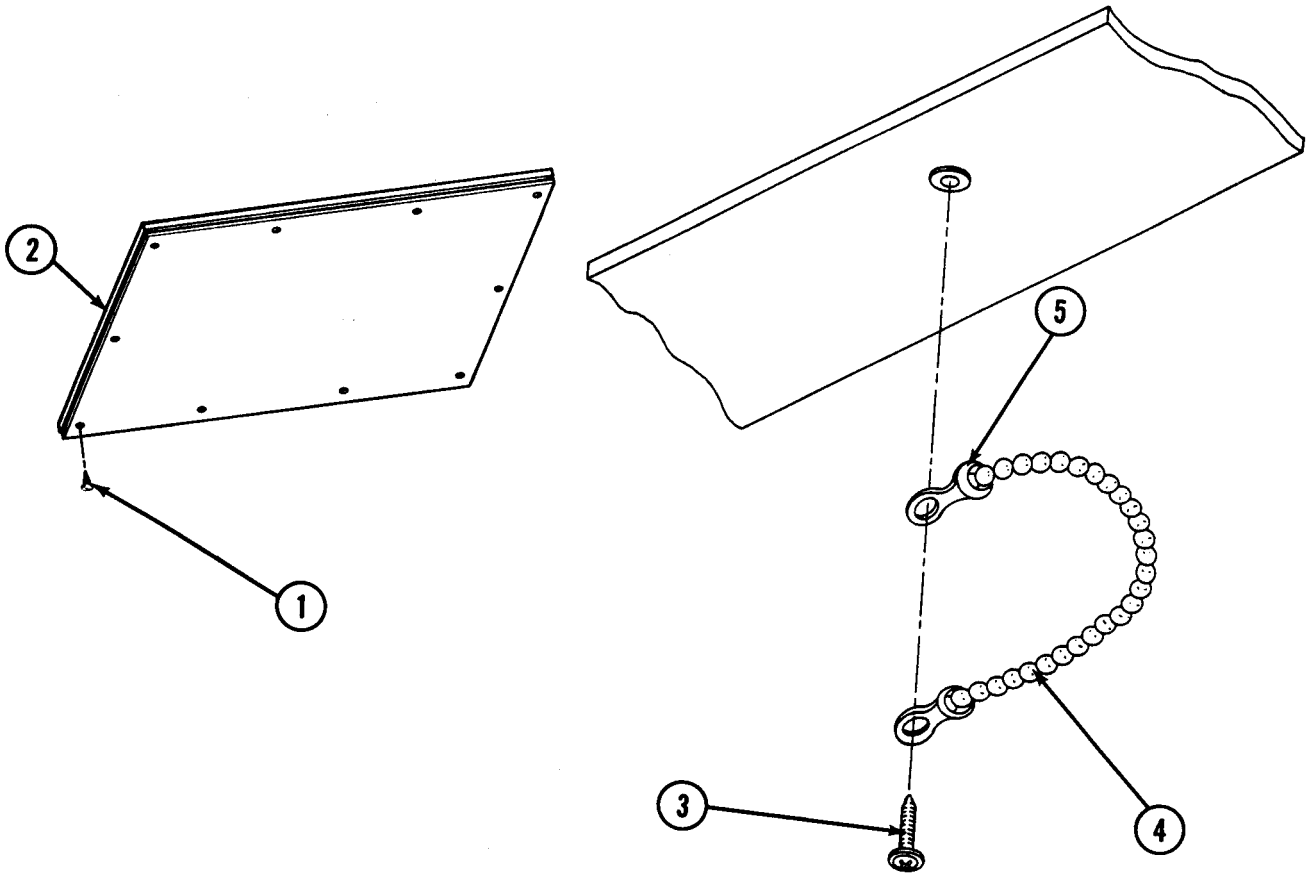

CAUTION

Cover Printing Press before removing screws. If screws fall into Printing Press, equipment damage may occur.

1. Remove screws (1) securing mirror (2) to ceiling.
2. Carefully remove mirror (2) from ceiling.
3. Remove screw (3) securing safety chain (4) and safety chain couplings (5) to ceiling.
4. Remove safety chain (4) and safety chain couplings (5).

2-22. REPLACE MIRROR AND SAFETY CHAIN (CONT)

INSTALLATION

1. Attach new safety chain couplings (5) to safety chain (4).
2. Place new safety chain coupling (5) over hole in ceiling and secure with screw (3).
- 30 Install mirror (2) on ceiling with screws (1).

2-23. REPAIR BOARDING LADDER ASSEMBLY

Boarding ladder assembly is repaired by replacing:

- a. Mounting bracket
- b. Lanyard and pin

MOUNTING BRACKET

INITIAL SETUP

Tools

Light machine repair tool kit (appendix B, section III, item 11)
Socket wrench set
Adjustable wrench

Materials/Parts

Ladder mounting bracket, 13225E3075 (middle)
Ladder mounting bracket, 13225E3703 (top)
Ladder mounting bracket, 13225E3076 (lower)

2-23. REPAIR BOARDING LADDER ASSEMBLY (CONT)

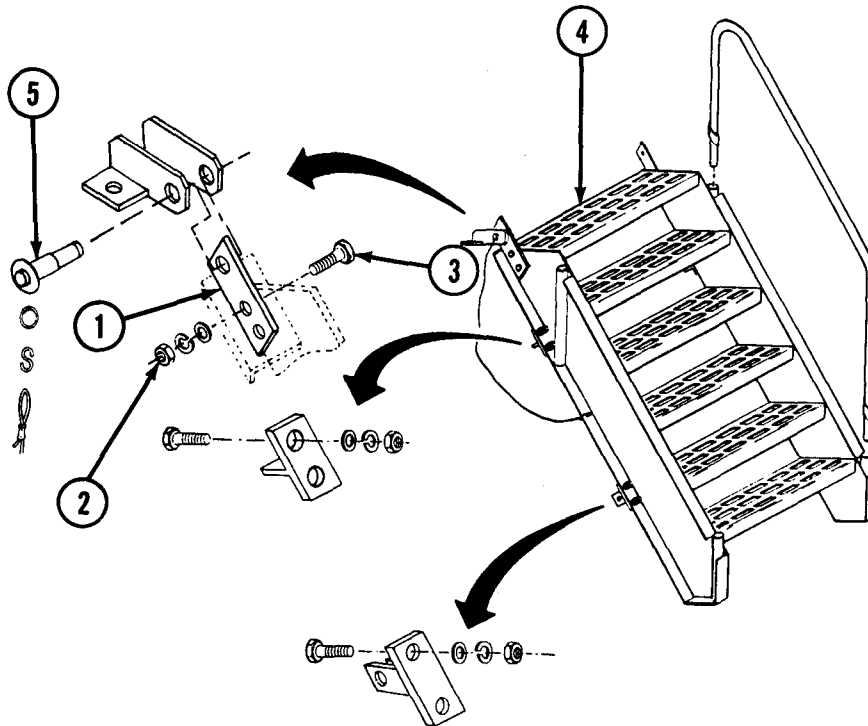

NOTE

If top mounting brackets are to be removed, boarding ladder must be detached.

1. At mounting bracket (1), remove hex nuts (2), lockwashers, flatwashers, and hex bolts (3).
2. Align new mounting brackets (1) with holes on ladder (4).
3. Install hex bolts (3), flatwashers, lockwashers, and hex nuts (2).
4. If necessary, place ladder (4) back on Section and secure with quick-release pins (5).

2-23. REPAIR BOARDING LADDER ASSEMBLY (CONT)

LANYARD AND PIN

INITIAL SETUP

Tools

Light machine repair tool kit (appendix B, section III, item 11)
Pliers

Materials/Parts

S-hook, 9520K14 (2 required)
Lanyard, 13225E3074-5
Quick-release pin, MS17987-412

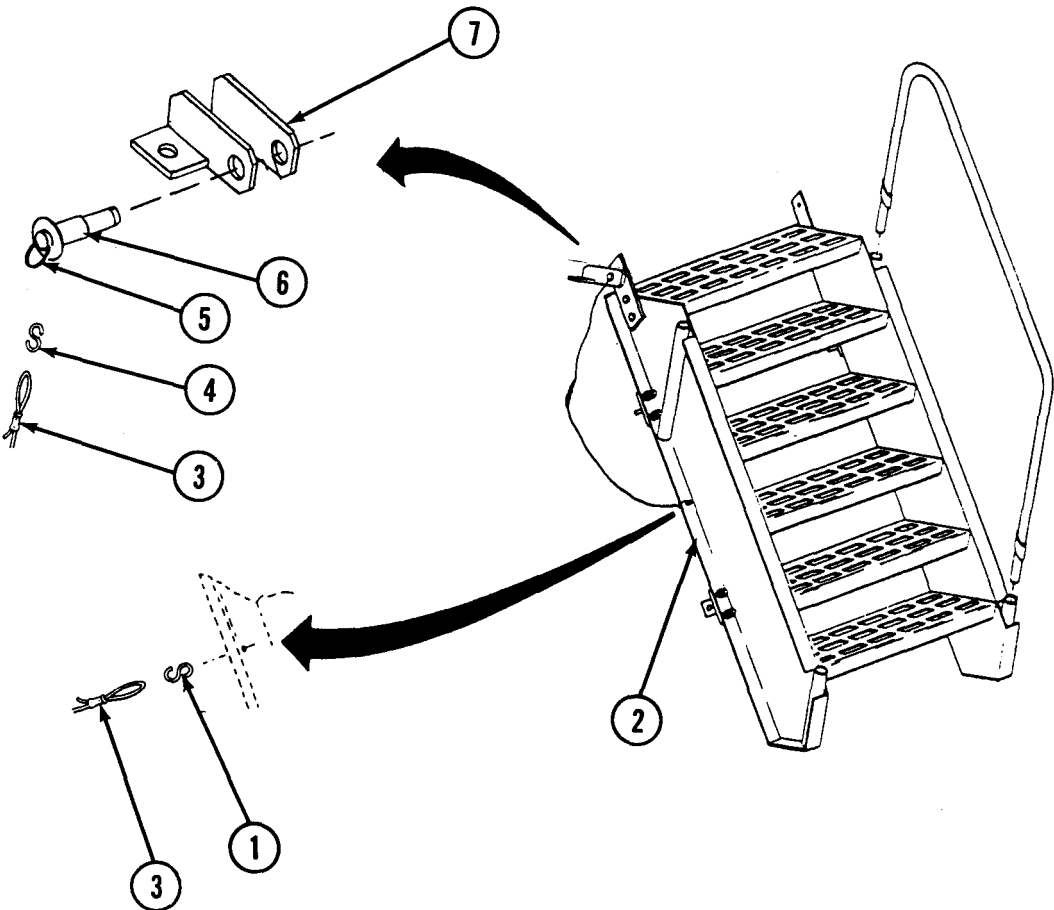

2-23. REPAIR BOARDING LADDER ASSEMBLY (CONT)

1. Remove S-hook (1) from ladder (2) and lanyard (3).
2. Remove S-hook (4) from retaining ring (5) and lanyard (3).
3. Remove quick-release pin (6) from mounting bracket (7).
4. At mounting bracket (7), install new quick-release pin (6).
5. Install new S-hook (4) on new lanyard (3) and new retaining ring (5).
6. Install new S-hook (1) on ladder (2) and new lanyard (3).

2-24. REPLACE FOLDING LADDER SUPPORT BRACKETS

This task covers: a. Removal b. Installation

INITIAL SETUP

Tools

Light machine repair tool kit (appendix B, section III, item 11)
Socket wrench set
Scraping knife (appendix B, section III, item 9)

Materials/Parts

Folding ladder support bracket, 13226E7936-1
Folding ladder support bracket, 13226E7936-2
Rubber seal, 13227E5688 (2 required)
Adhesive (appendix C, item 1)
Rubber cement thinner (appendix C, item 33)

2-24. REPLACE FOLDING LADDER SUPPORT BRACKETS (CONT)

REMOVAL

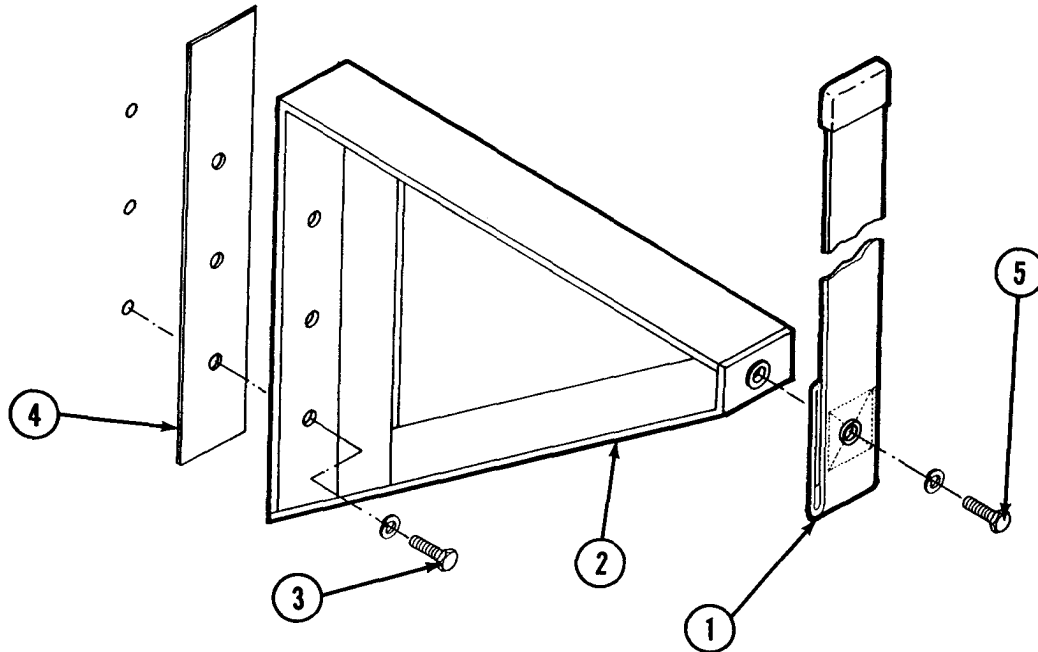

1. Unlock strap (1) and remove folding ladder from support brackets (2).
2. Remove bolts (3) and lockwashers securing support brackets (2) to Section body.
3. Remove each rubber seal (4) and support bracket (2) from Section body.
4. Scrape rubber residue from Section body.

WARNING

CHEMICAL HAZARD. Use rubber cement thinner in a well-ventilated area. Failure to do so may result in damage to respiratory system. Wear gloves and goggles to prevent injuries to skin and eyes.

5. Clean rubber residue from Section body with rubber cement thinner.
6. Remove bolt (5) and lockwasher securing strap assembly (1) to support bracket (2). Remove strap assembly (1).

2-24. REPLACE FOLDING LADDER SUPPORT BRACKETS (CONT)

INSTALLATION

1. Install strap assembly (1) on new mounting bracket (2) with bolt (5) and lockwasher.

WARNING

CHEMICAL HAZARD. Use adhesive in a well-ventilated area. Adhesive is harmful to eyes and skin. In case of contact with eyes, immediately flush eyes with water for 15 minutes, then seek medical help. In case of contact with skin, wipe off with dry cloth, then wash with soap and water.

2. Apply adhesive to back of new rubber seal (4).
3. Position new rubber seal (4) on new support bracket (2).
4. Install support bracket (2) with bolts (3) and lockwashers.
5. Place folding ladder on support brackets (2) and secure with straps (1).

2-25. REPAIR FOLDING LADDER SUPPORT BRACKETS

Folding ladder support brackets are repaired by replacing: Strap and buckle assembly/strap assembly

STRAP AND BUCKLE ASSEMBLY/STRAP ASSEMBLY

INITIAL SETUP

Tools

Light machine repair tool kit (appendix B, section III, item 11)
Portable electric drill
Twist drill set
Socket wrench set
Rivet gun (appendix B, section III, item 10)

Materials/Parts

Strap and buckle assembly, 13226E7833-3
Strap assembly, 13225E3865
Rivets, MS20600-AD6W4

2-25. REPAIR FOLDING LADDER SUPPORT BRACKETS (CONT)

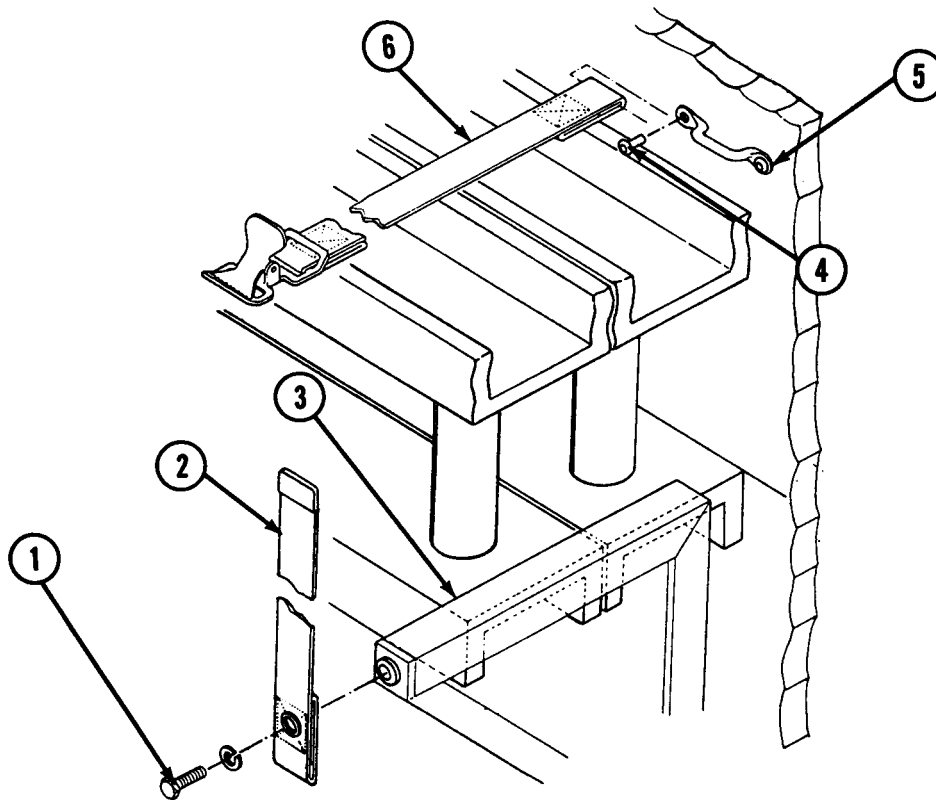

1. Remove hex bolt (1), lockwasher, and strap assembly (2) from support bracket (3).
2. Drill out rivets (4) securing loop strap fastener (5). Remove strap and buckle assembly (6).
3. Install new strap assembly (2) on support bracket (3) with hex bolt (1) and lockwasher.
4. Thread loop strap fastener (5) through strap and buckle assembly (6).
5. Install loop strap fastener (5) with rivets (4).

2-26. REPAIR AIR CONDITIONER/HEATER MOUNTING BRACKET

Air conditioner/heater mounting bracket is repaired by replacing: Drain tube

DRAIN TUBE

INITIAL SETUP

Tools

Light machine repair tool kit (appendix B, section III, item 11)
Combination wrench
Knife (appendix B, section III, item 16)
Pliers (appendix B, section III, item 15)

Materials/Parts

Ferrule, 508K130
Drain tube, PFT-6B
Tiedown strap, MIL-S-23190D, type I, class I (8 required)
Paint (appendix C, items 18, 19; 20)
Spray kit (appendix C, item 26)
Aliphatic thinner (appendix C, item 32)

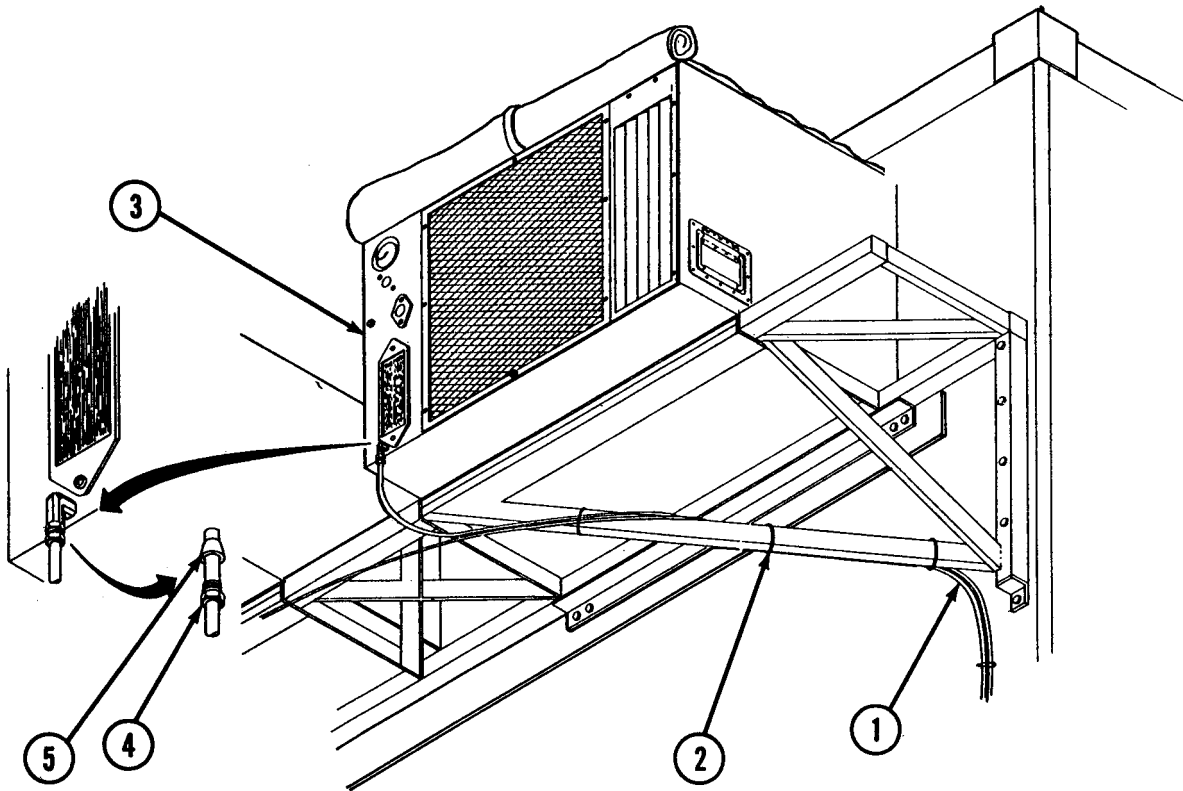

2-26. REPAIR AIR CONDITIONER/HEATER MOUNTING BRACKET (CONT)

1. Along drain tube (1), cut tiedown straps (2).
2. Remove drain tube (1) from air conditioner/heater (3) by loosening hex nut (4).
3. Remove hex nut (4) from old drain tube (1).
4. Thread new drain tube (1) through hex nut (4) and slide on new ferrule (5).

CAUTION

Finger-tighten nut before wrench tightening to avoid cross-threading. Failure to do so may damage equipment.

5. Install new drain tube (1) to air conditioner/heater (3) with hex nut (4). Finger-tighten hex nut (4), then wrench-tighten.
6. Install drain tube (1) to Section body and mounting bracket with tie-down straps (2).
7. Paint drain tubes (1) and tiedown straps (2) in accordance with TM 43-0139.

2-27. REPLACE WALL STORAGE CABINET

This task covers: a. Removal b. Installation

INITIAL SETUP

Tools

Light machine repair tool kit (appendix B, section III, item 11)
Socket wrench set
Cross-tip screwdriver

Materials/Parts

Wall storage cabinet, MIL-C-400600/1, Type 1

2-27. REPLACE WALL STORAGE CABINET (CONT)

REMOVAL

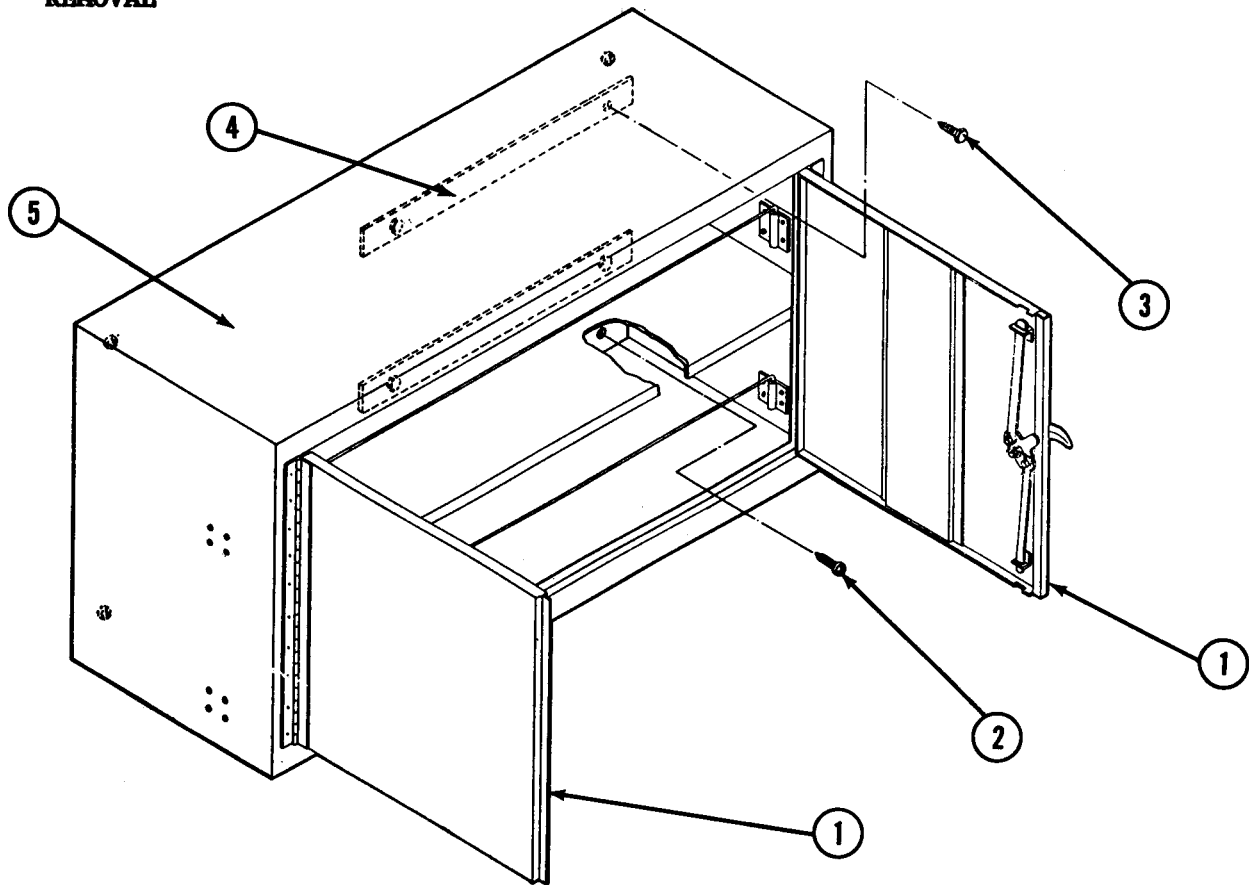

1. Open wall storage cabinet doors (1).
2. Remove screws (2) from corners of cabinet.
3. Remove hex bolts (3) and two stiffener bars (4) from rear of wall storage cabinet (5). Remove wall storage cabinet (5) from wall.

INSTALLATION

1. Secure new wall storage cabinet (5) to wall with two stiffener bars (4) and hex bolts (3).
2. Install corner screws (2).
3. Close cabinet doors (1).

2-28. REPAIR WALL STORMS CABINET

Wall storage cabinet is repaired by replacing: Handle and latch assembly

HANDLE AND LATCH ASSEMBLY

INITIAL SETUP

Tools

- Light machine repair tool kit (appendix B, section III, item 11)
- Socket wrench set
- Flat-tip screwdriver
- Pliers

Materials/Parts

- Handle and latch assembly, 92-20-305-72

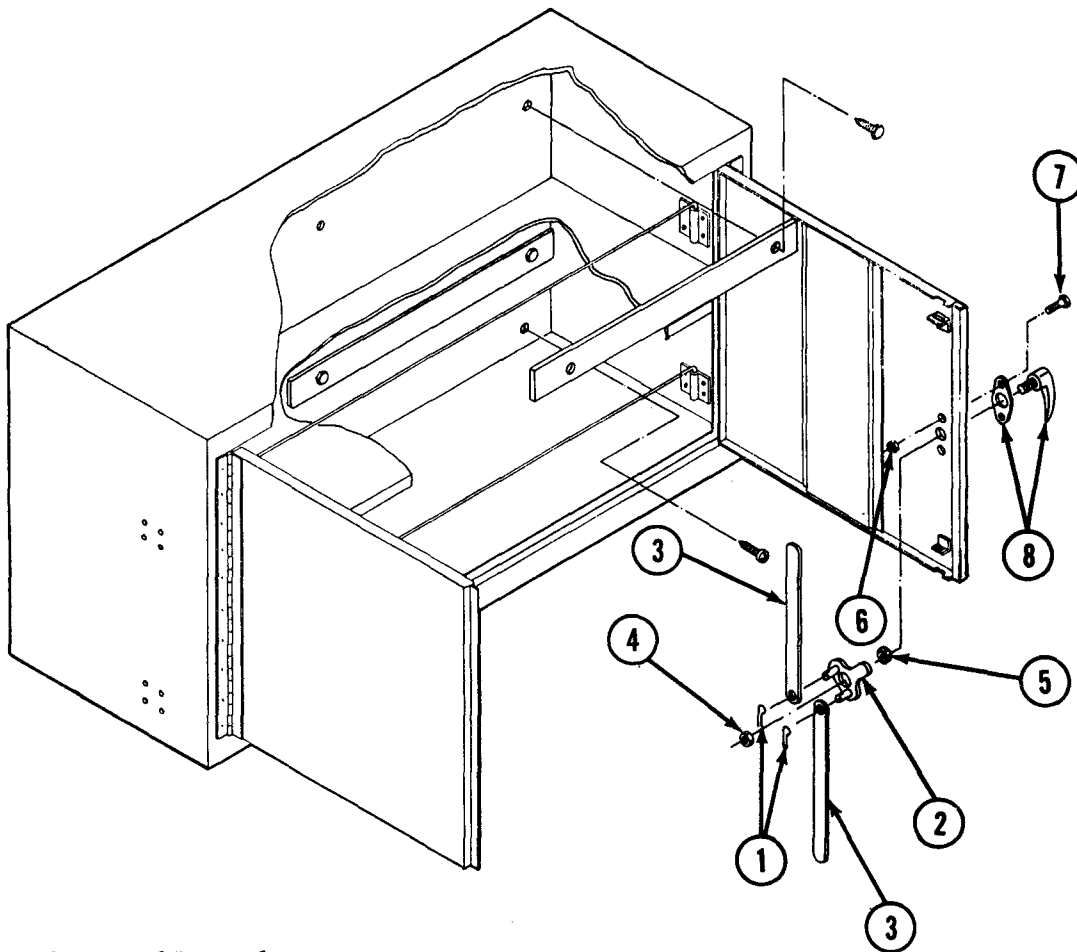

1. Open cabinet doors.
2. Remove cotter pins (1) and flatwashers from striker (2). Disconnect rods (3) from striker (2).

2-28. REPAIR WALL STORAGE CABINET (CONT)

3. Remove hex nut (4), striker (2), and hex nut (5) behind striker (2). Remove nuts (6), screws (7), and handle and latch assembly (8).
4. Place new handle and latch assembly (8) on wall storage cabinet door.
5. Install handle and latch assembly (8) with nuts (6) and screws (7).
6. Install hex nut (5), striker (2), and hex nut (4) on handle and latch assembly (8).
7. Close cabinet doors and check position of striker. Adjust striker in or out with hex nuts (4) and (5).
8. Install rods (3) with cotter pins (1) and flatwashers.
9. Close cabinet doors.

2-29. REPLACE ROLLER STORAGE RACK

This task covers: a. Removal b. Installation

INITIAL SETUP

Tools

Light machine repair tool kit (appendix B, section III, item 11)
Portable electric drill
Socket wrench set
Cross-tip screwdriver
Rivet gun (appendix B, section III, item 10)

Materials/Parts

Top roller rack assembly, 13226E7838
Lower roller rack assembly, 13226E7876
Rivets, MS20600-MP4W6 (4 required)
Lead pencil (appendix C, item 13)

2-29. REPLACE ROLLER STORAGE RACK (CONT)

REMOVAL

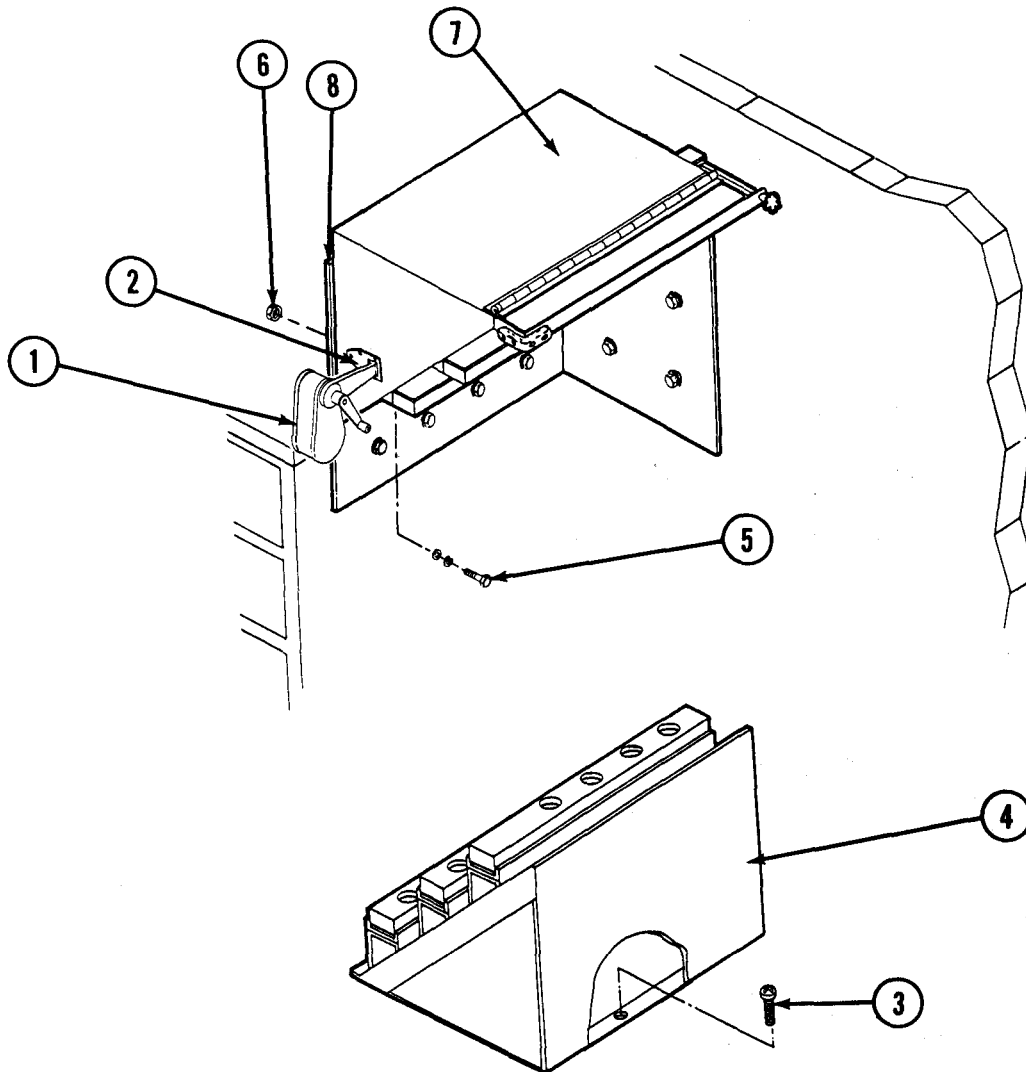

1. Remove rollers from roller rack assembly.
2. Remove pencil sharpener (1) by drilling out rivets (2).
3. Remove screws (3) and lower roller rack assembly (4).
4. Remove bolts (5), lockwashers, flatwashers, nuts (6), and top roller rack assembly (7) from top roller rack mounting plate (8).

2-29. REPLACE ROLLER STORAGE RACK (CONT)

INSTALLATION

1. Install new top roller rack assembly (7) on top roller rack mounting plate (8) with bolts (5), lockwashers, flatwashers, and nuts (6). Do not tighten.
2. Position pencil sharpener (1) on side of top roller rack assembly (7) and mark holes for rivets.
3. Drill holes for pencil sharpener (1) and install with rivets (2).
4. Install new lower roller rack assembly (4) with screws (3).
5. Install one roller on each side of roller rack assembly.
6. Adjust top roller rack assembly (7) and tighten bolts (5).

2-30. REPAIR ROLLER STORAGE RACK

Roller storage rack is repaired by replacing: Wood rack and rubber pad

WOOD RACK AND RUBBER PAD

INITIAL SETUP

Tools

- Light machine repair tool kit (appendix B, section III, item 11)
- Cross-tip screwdriver
- Offset cross-tip screwdriver

Materials/Parts

- 5-hole lower wood rack, 13226E7878 (2 required)
- 4-hole lower wood rack, 13226E7879
- Rubber pad, MIL-R-6855, CL-1, GR-60 (2" x 17") (3 required)

2-30. REPAIR ROLLER STORAGE RACK (CONT)

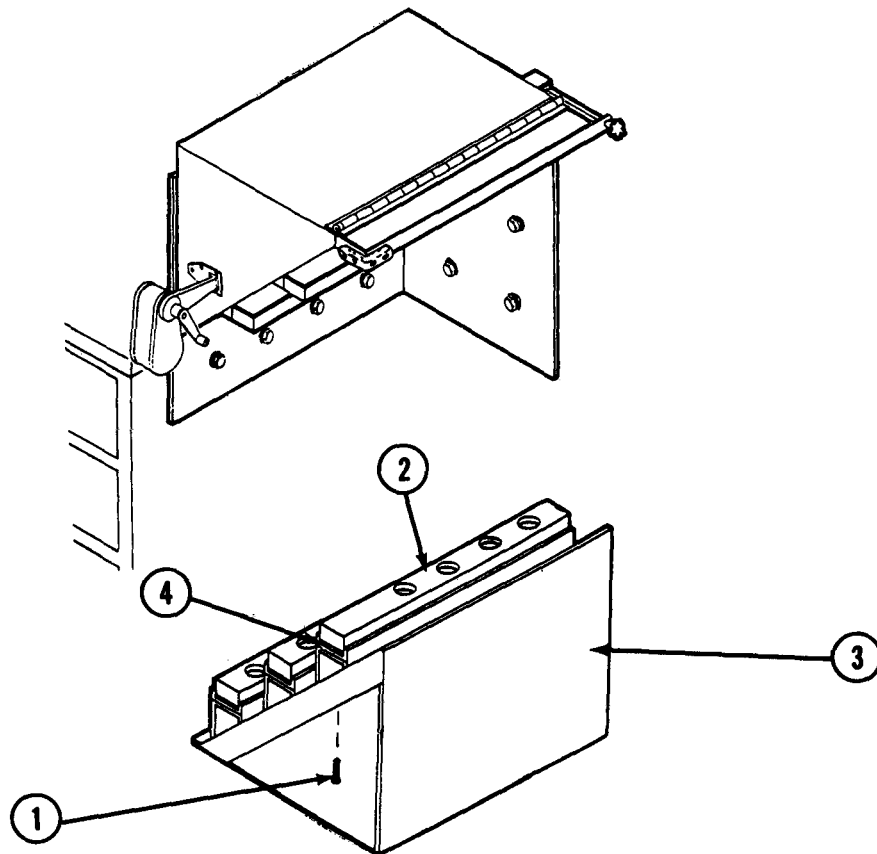

1. Remove screws (1) securing wood racks (2) to roller rack assembly (3).
2. Remove wood rack (2) and rubber pad (4).

NOTE

Wood rack is made of oak which may require starting holes before installing.

3. Install new rubber pad (4) and new wood rack (2) on roller rack assembly (3) with screws (1).

2-31. REPLACE SPARE ROLLER RACK ASSEMBLY

This task covers: a. Removal b. Installation

INITIAL SETUP

Tools

Light machine repair tool kit (appendix B, section III, item 11)
 Cross-tip screwdriver
 Scraping knife (appendix B, section III, item 9)

2-31. REPLACE SPARE ROLLER RACK ASSEMBLY (CONT)

Materials/Parts

Spare roller rack assemblies, 13226E7862 (2 required)
Roller rack cover bases, 13226E7831 (2 required)
Adhesive (appendix C, item 1)
Rubber cement thinner (appendix C, item 33)
Rag (appendix C, item 24)

REMOVAL

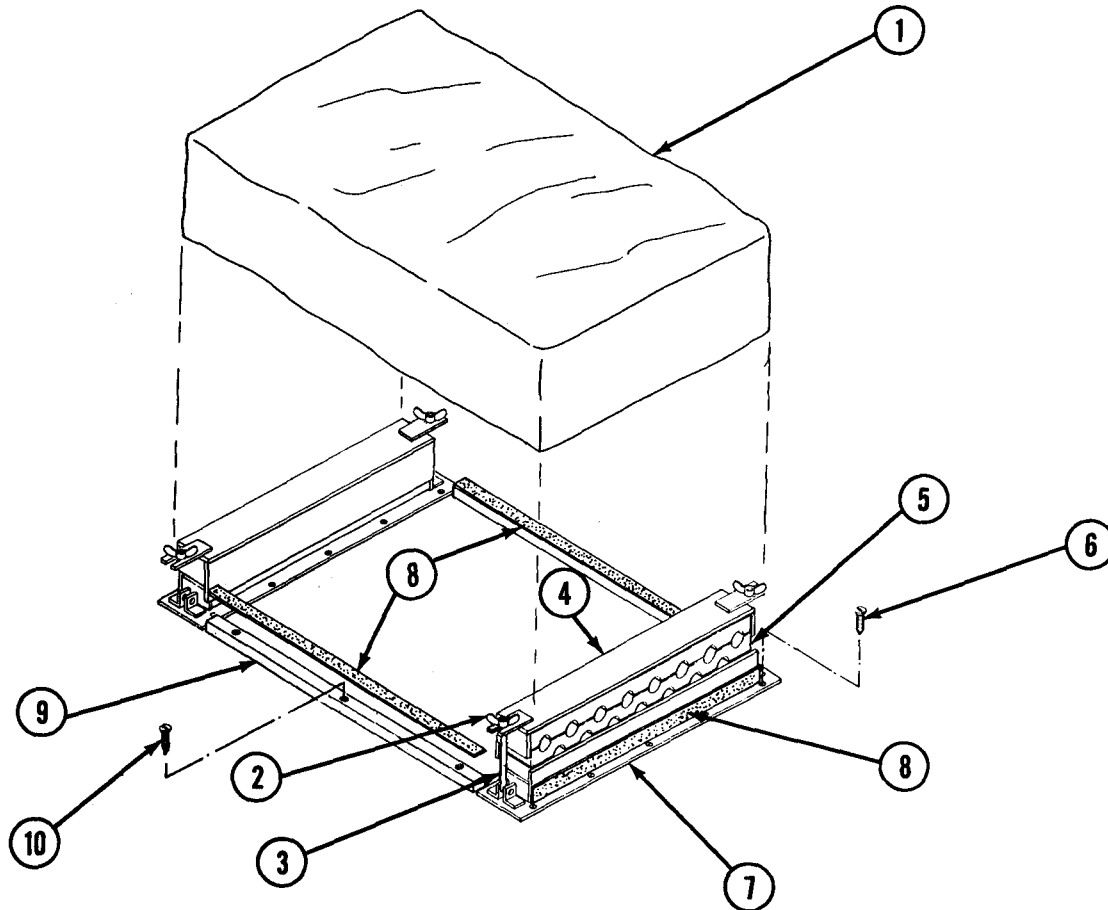

1. Disconnect blackout curtain from equipment door.

WARNING

Secure equipment door in open position to avoid being hit by swinging door. Failure to observe this warning may result in serious injury.

2. Unlock upper and lower equipment door latches. Open and secure equipment door.

2-31. REPLACE SPARE ROLLER RACK ASSEMBLY (CONT)

3. Remove roller rack cover (1) from roller rack assembly.
4. Loosen wingnuts (2) on locking spindles (3) securing two top frames (4).
5. Remove top frames (4).
6. Remove top rollers from roller rack assembly.
7. Remove center supports (5).
8. Remove lower rollers from roller rack assembly.
9. Remove screws (6) securing bottom of each roller rack bottom frame (7).
10. Remove roller rack bottom frames (7).
11. Carefully remove tape fasteners (8) from each roller rack cover base (9) and side of each roller rack bottom frame (7).
12. Remove screws (10) and roller rack cover bases (9).

INSTALLATION

1. Install new roller rack cover bases (9) with screws (10).
2. Install tape fasteners (8) to roller rack cover bases (9) with adhesive.
3. Install tape fasteners (8) to sides of new roller rack bottom frames (7).
4. Install roller rack bottom frames (7) with screws (6).
5. Install lower rollers.
6. Install new center supports (5).
7. Install top rollers.
8. Install new top frames (4). Secure wingnuts (2) on locking spindles (3).

2-31. REPLACE SPARE ROLLER RACK ASSEMBLY (CONT)

9. Install roller rack cover (1).
10. Close and lock equipment door.
11. Connect blackout curtain to equipment door.

2-32. REPLACE SPARE ROLLER RACK COVER

This task covers: a. Removal b. Installation

INITIAL SETUP

Tools

Scraping knife (appendix B, section III, item 9)

Materials/Parts

Roller rack cover, 13226E7832
Adhesive (appendix C, item 1)
Rubber cement thinner (appendix C, item 33)
Rag (appendix C, item 24)

2-32. REPLACE SPARE ROLLER RACK COVER (CONT)

REMOVAL

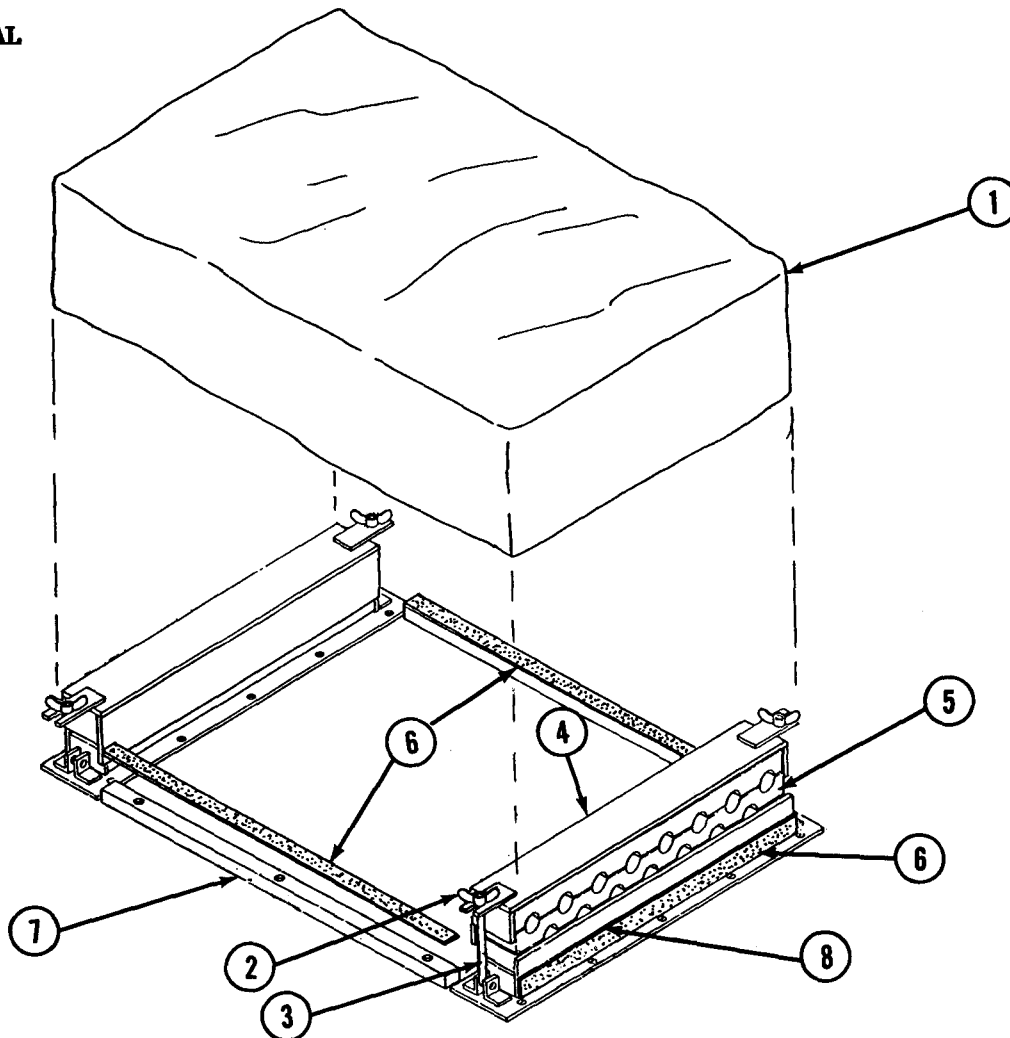

1. Disconnect blackout curtain from equipment door..

WARNING

Secure equipment door in open position to avoid being hit by swinging door. Failure to observe this warning may result in serious injury.

2. Unlock upper and lower equipment door latches. Open and secure equipment door.
3. Remove roller rack cover (1) from roller rack assembly.
4. Loosen wingnuts (2) on locking spindles (3) securing two top frames (4).

2-32. REPLACE SPARE ROLLER RACK COVER (CONT)

5. Remove top frames (4).
6. Remove top rollers from roller rack assembly.
7. Remove two center supports (5).
8. Remove lower rollers.
9. Remove tape fasteners (6) from roller rack cover bases (7) and side of roller rack bottom frames (8).
10. Scrape adhesive residue from roller rack cover base (7).

WARNING

CHEMICAL HAZARD. Use rubber cement thinner in a well-ventilated area. Failure to do so may result in damage to respiratory system. Wear gloves and goggles to prevent injuries to skin and eyes.

11. Clean adhesive residue from roller rack bottom frames (8) with rubber cement thinner.

INSTALLATION

WARNING

CHEMICAL HAZARD. Use adhesive in a well-ventilated area. Adhesive is harmful to eyes and skin. In case of contact with eyes, immediately flush eyes with water for 15 minutes, then seek medical help. In case of contact with skin, wipe off with dry cloth, then wash with soap and water.

1. Install new tape fasteners on roller rack cover bases (7) and side of roller rack bottom frames (8) with adhesive.
2. Install lower rollers.
3. Install center supports (5).
4. Install top rollers.
5. Install top frames (4) and secure wingnuts (2) on locking spindles (3).
6. Install new roller rack cover (1).
7. Close and lock equipment door.
8. Connect blackout curtain to equipment door.

2-33. REPLACE MODIFIED FIVE-DRAWER STORAGE CABINET

This task covers: a. Removal b. Installation

INITIAL SETUP

Tools

- Light machine repair tool kit (appendix B, section III, item 11)
- Socket wrench set

Materials/Parts

Modified five-drawer storage cabinet, 13227E5707

REMOVAL

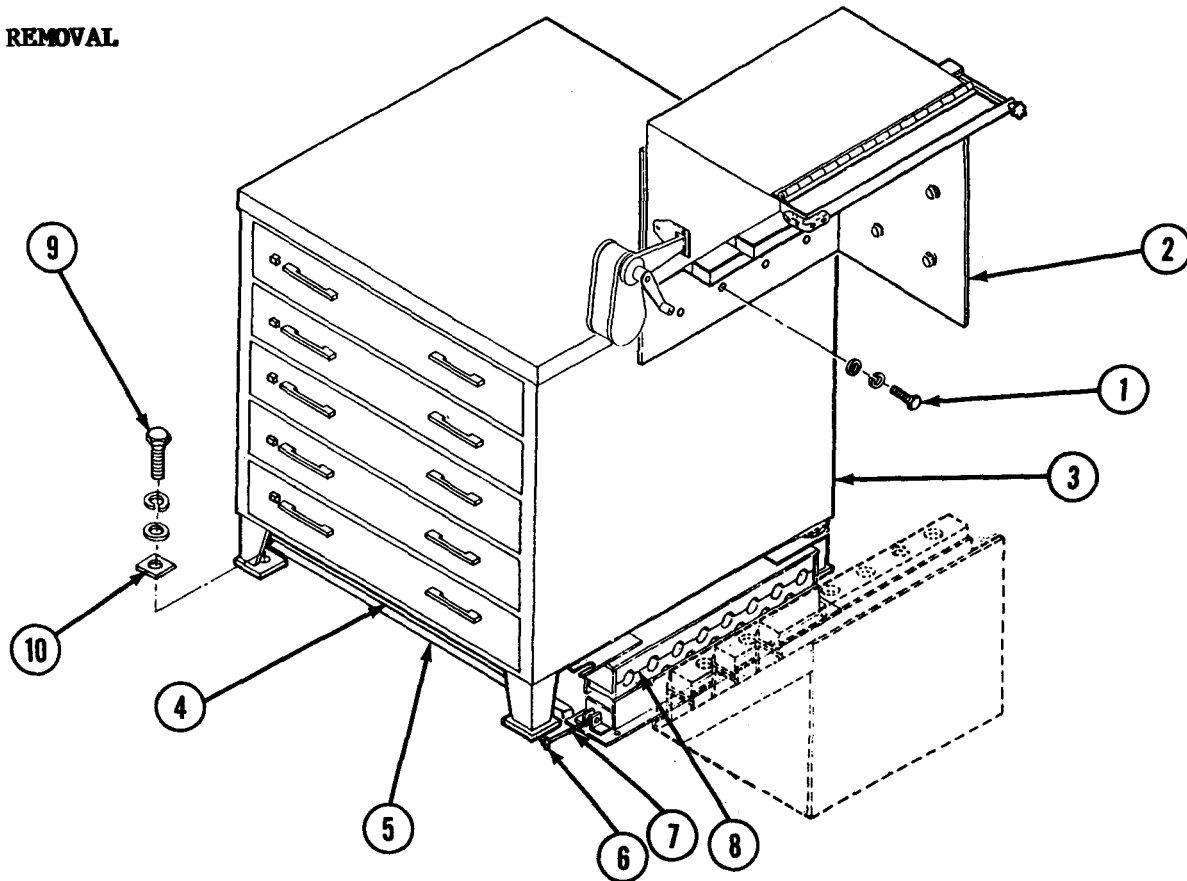

1. Disconnect blackout curtain from equipment door.

WARNING

Secure equipment door in open position to avoid being hit by swinging door. Failure to observe this warning may result in serious injury.

2. Unlock upper and lower latches on equipment door. Open and secure equipment door.

2-33. REPLACE MODIFIED FIVE-DRAWER STORAGE CABINET (CONT)

3. Remove rollers from roller rack assembly.
4. Remove bolts (1), lockwashers, and flatwashers securing upper roller rack assembly mounting plate (2) to modified five-drawer storage cabinet (3).
5. Remove roller rack cover (4) from spare roller rack (5).
6. Loosen wingnuts (6) on locking spindles (7) and remove spare roller rack top frames (8).
7. Remove rollers from spare roller rack (5).
8. Remove bolts (9), lockwashers, flatwashers, and mounting plates (10) securing modified five-drawer storage cabinet (3) to floor.

WARNING

Storage cabinet weighs approximately 70 pounds (32 kg). Use proper lifting techniques. Do not attempt to lift by yourself. Failure to observe this warning may result in personal injury.

9. Remove storage cabinet (3).

INSTALLATION

1. Install new modified five-drawer storage cabinet (3) with bolts (9), lockwashers, flatwashers, and mounting plates (10).
2. Secure storage cabinet (3) to upper roller rack assembly mounting plate (2) with bolts (1), lockwashers, and flatwashers.
3. Install rollers in spare roller rack (5).
4. Install top frames (8) on spare roller rack (5) and secure with wingnuts (6) and locking spindles (7).
5. Install cover (4) on spare roller rack (5).
6. Close and lock equipment door.
7. Connect blackout curtain to equipment door.

2-34. REPAIR MODIFIED FIVE-DRAWER STORAGE CABINET

Modified five-drawer storage cabinet is repaired by replacing: Latch and drawer handle

LATCH AND DRAWER HANDLE

INITIAL SETUP

Tools

- Light machine repair tool kit (appendix B, section III, item 11)
- Pliers
- Flat-tip screwdriver

Materials/Parts

- Latch assembly
- Drawer handle

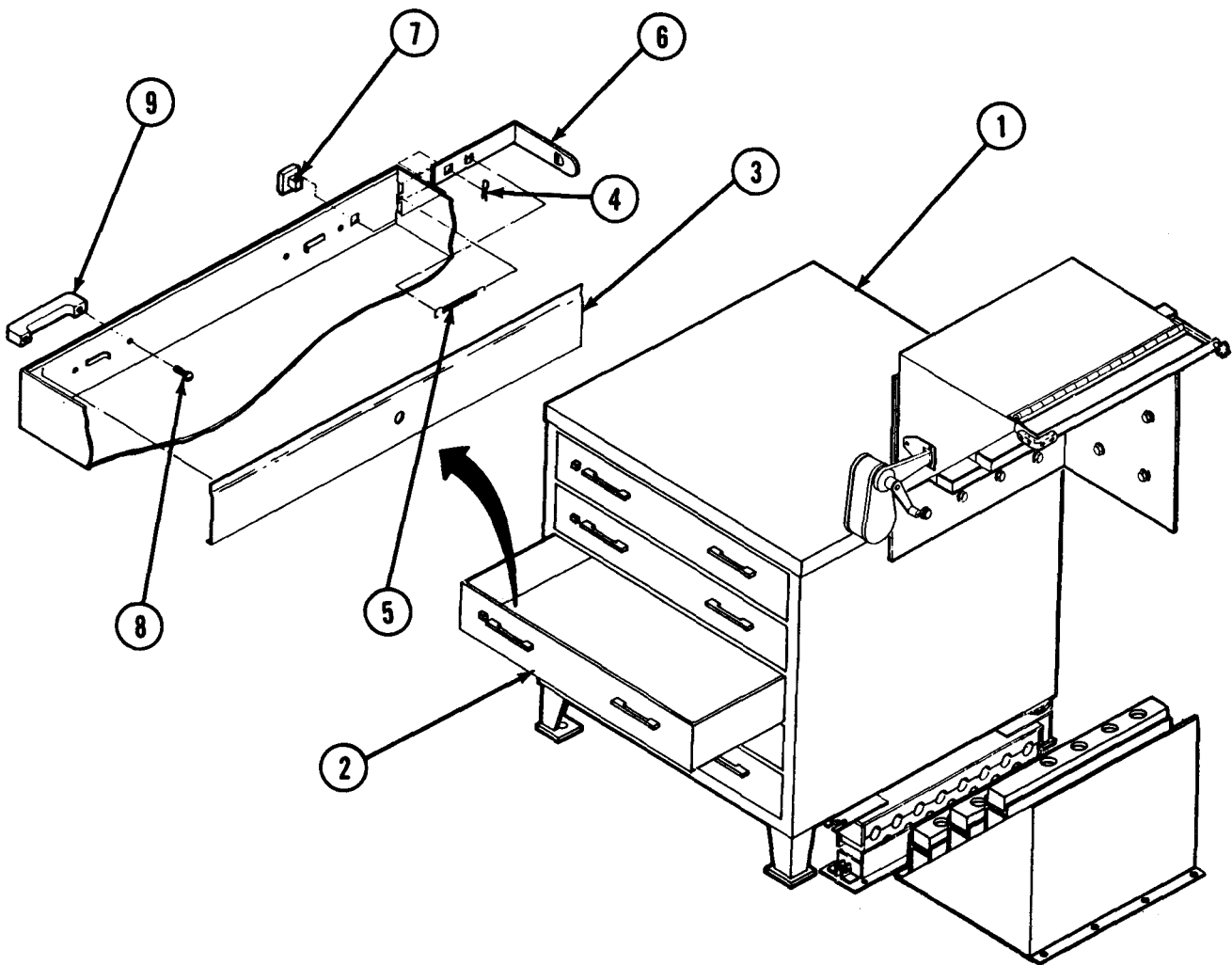

2-34. REPAIR MODIFIED FIVE-DRAWER STORAGE CABINET (CONT)

1. If necessary, remove thumbscrew and securing bar from front of cabinet (1).
2. Open drawer (2) and remove plate (3) by pulling at center hole inside drawer (2).
3. Remove cotter pin (4) and spring (5).
4. Remove latch bar (6) and knob (7).
5. Install new latch bar (6) and knob (7). Secure with spring (5) and cotter pin (4).
6. Remove screw (8) securing handle (9) to drawer (2).
7. Install new handle (9) with screws (8).
8. Install plate (3) inside front of drawer (2). Close drawer.
9. If necessary, install securing bar over front of cabinet (1) and secure with thumbscrew.

2-35. REPLACE JOGGING TABLE ASSEMBLY AND FEEDER PILE BOARD STORAGE RACK

This task covers: a. Removal b. Installation

INITIAL SETUP

Tools

Light machine repair tool kit (appendix B, section III, item 11)
Socket wrench set
Flat-tip screwdriver
Cross-tip screwdriver

Materials/Parts

Jogging table assembly, 13227E5706
Feeder board locking bracket, 13226E7926
Feeder storage rack support frame, 13226E7893
Wood feeder guide, 13226E7886 (2 required)
Steel feeder guide, 13226E7885
Feeder board locking brace, 13226E7898

2-35. REPLACE JOGGING TABLE ASSEMBLY AND FEEDER PILE BOARD STORAGE RACK
(CONT)

REMOVAL

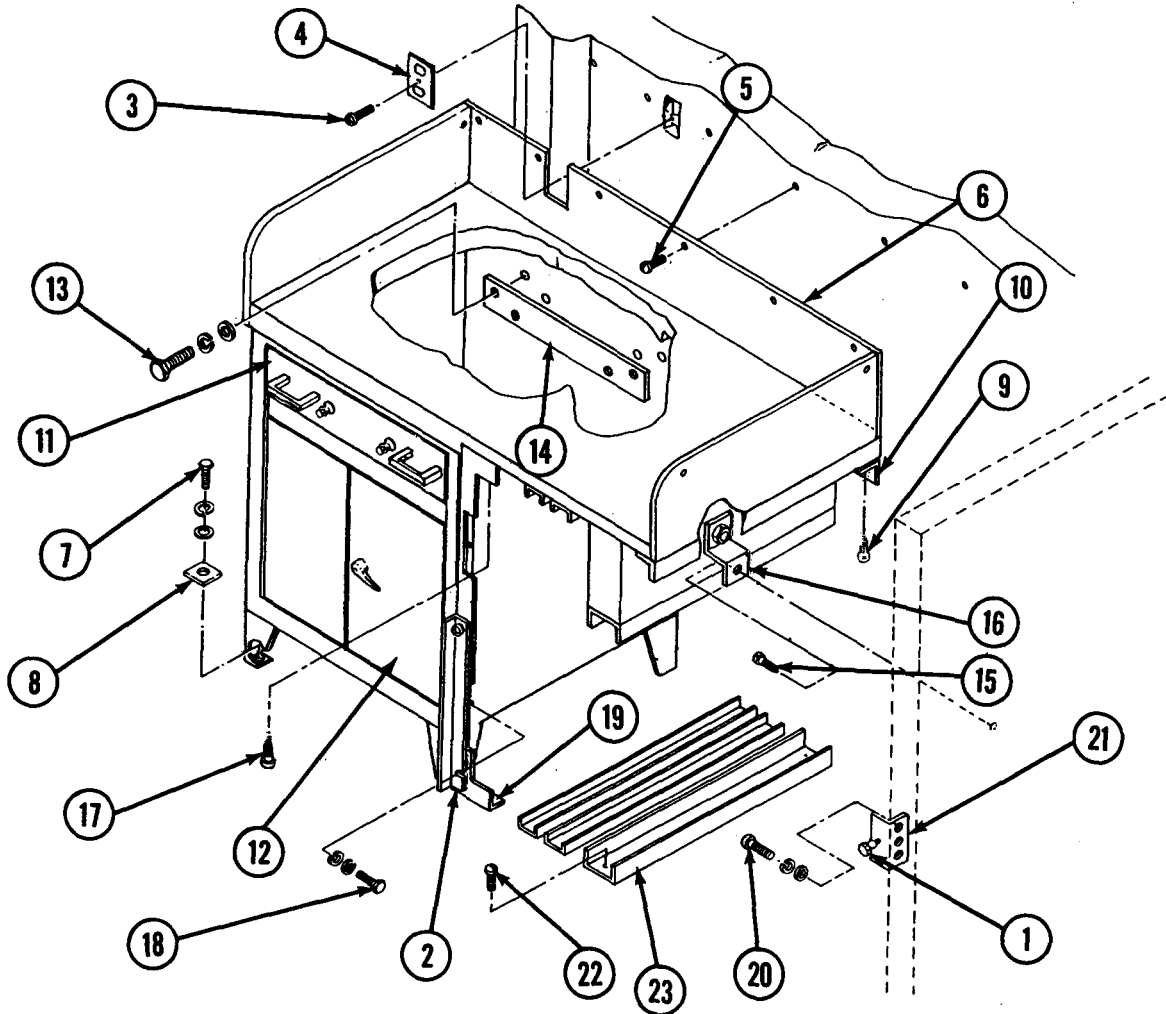

1. Loosen cast iron knob (1) and lower locking brace (2).
2. Remove feeder pile and delivery pile boards.
3. Remove screw (3) and electrical outlet cover plate (4).
4. Remove screws (5) securing side panels (6) to wall.
5. Remove lag bolts (7), lockwashers, flatwashers, and mounting plates (8).
6. Remove screws (9) securing back mounting bracket (10) to jogging table assembly.

2-35. REPLACE JOGGING TABLE ASSEMBLY AND FEEDER PILE BOARD STORAGE RACK
(CONT)

7. Remove drawer (11) and open cabinet doors (12). Remove hex bolts (13), lockwashers, flatwashers, and stiffener bar (14) inside cabinet.
8. Remove screw (15) from support bracket (16).

WARNING

Jogging table assembly weighs approximately 200 pounds (91 kg). Use proper lifting techniques. Do not attempt to lift by yourself. Failure to observe this warning may result in personal injury.

9. Pull jogging table assembly away from wall.
10. Remove screws (17), bolts (18), lockwashers, and flatwashers. Separate feeder storage rack support (19) from jogging table assembly.
11. Remove screws (20), lockwashers, and flatwashers. Separate locking bracket (21) from wall.
12. Remove screws (22) securing each feeder guide (23) to floor. Remove feeder guides (23).

INSTALLATION

1. Install each feeder guide (23) with screws (22).
2. Install locking bracket (21) with screws (20), lockwashers, and flatwashers.
3. Install feeder storage rack support (19) on jogging table assembly with bolts (18), flatwashers, and lockwashers. Install screws (17).

WARNING

Jogging table assembly weighs approximately 200 pounds (91 kg). Use proper lifting techniques. Do not attempt to lift by yourself. Failure to observe this warning may result in personal injury.

4. Position jogging table assembly against wall.
5. Install feeder bar rack support bracket (16) with screw (15).

**2-35. REPLACE JOGGING TABLE ASSEMBLY AND FEEDER PILE BOARD STORAGE RACK
(CONT)**

6. Inside cabinet, install stiffener bar (14) with hex bolts (13), lockwashers, and flatwashers. Close cabinet doors (12) and install drawer (11).
7. Install back mounting bracket (10) with screws (9).
8. Secure jogging table assembly to floor with lag bolts (7), lockwashers, flatwashers, and mounting plates (8).
9. Install side panels (6) with screws (5).
10. Install electrical outlet cover plate (4) with screw (3).
11. If necessary, install feeder pile and delivery pile boards.
12. Secure locking brace (2) and tighten cast iron knob (1).

2-36. REPAIR JOGGING TABLE ASSEMBLY AND FEEDER PILE BOARD STORAGE RACK

Jogging table assembly and feeder pile board storage rack is repaired by replacing: Cabinet

CABINET

INITIAL SETUP

Tools

- Light machine repair tool kit (appendix B, section III, item 11)
- Socket wrench set
- Cross-tip screwdriver
- Offset screwdriver

Materials/Parts

- Jogging table storage cabinet, 13227E5705

2-36. REPAIR JOGGING TABLE ASSEMBLY AND FEEDER PILE BOARD STORAGE RACK
(CONT)

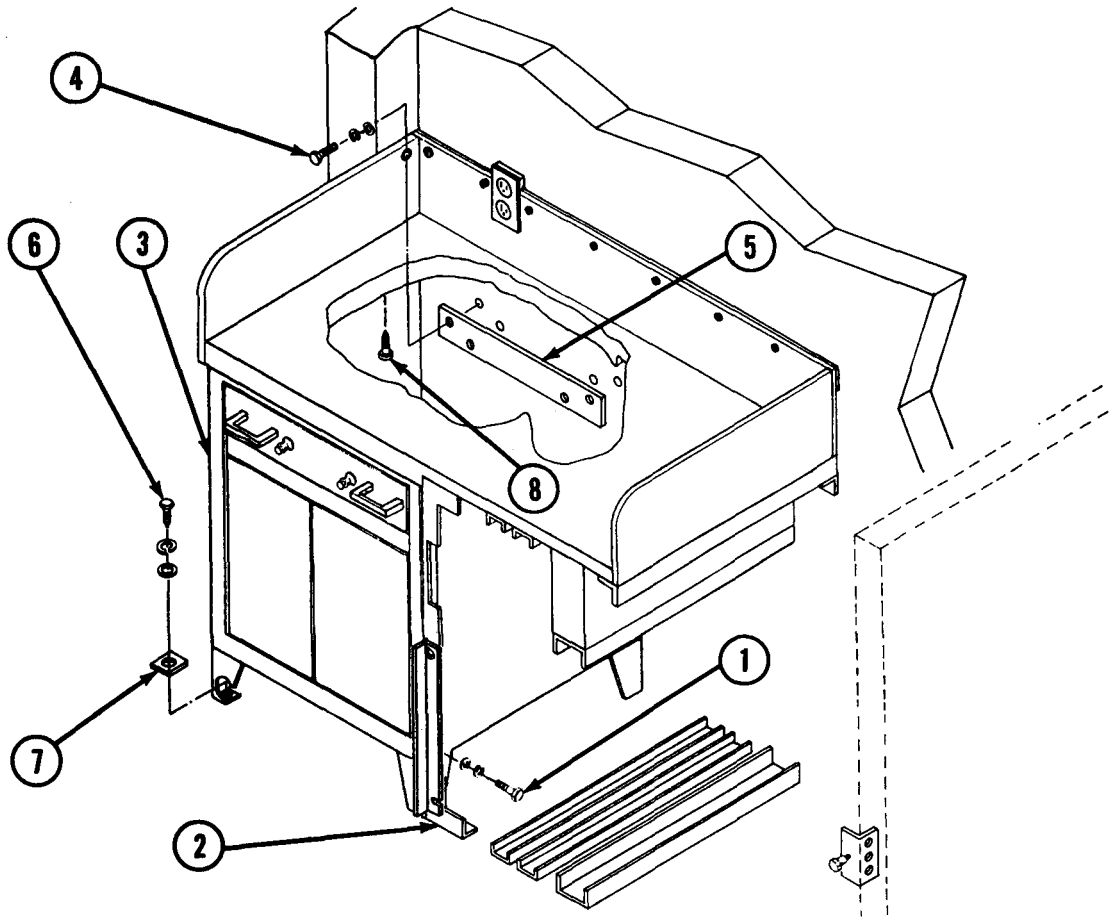

1. Remove bolts (1), lockwashers, and flatwashers securing feeder storage rack support frame (2) to cabinet (3).
2. Remove bolts (4), lockwashers, flatwashers, and stiffener bar (5) from back of cabinet (3).
3. Remove lag bolts (6), lockwashers, flatwashers, and mounting plates (7) securing cabinet (3) to floor.

WARNING

Cabinet weighs approximately 100 pounds (45 kg). Use proper lifting techniques. Do not attempt to lift by yourself. Failure to observe this warning may result in personal injury.

4. Remove screws (8) securing cabinet (3) to jogging table top. Remove cabinet (3).
5. Install new cabinet (3) under jogging table top with screws (8).

**2-36. REPAIR JOGGING TABLE ASSEMBLY AND FEEDER PILE BOARD STORAGE RACK
(CONT)**

6. Install cabinet (3) to floor with hex bolts (6), lockwashers, flatwashers, and mounting plate (7).
7. Install stiffener bar (5) to back of cabinet (3) with bolts (4), lockwashers, and flatwashers.
8. Install feeder storage rack support frame (2) with bolts (1), lockwashers, and flatwashers.

2-37. REPAIR GTO STORAGE CABINET ASSEMBLY

GTO storage cabinet assembly is repaired by replacing: a. Plate storage box b. Bracket assembly c. Magnifier mounting bracket

PLATE STORAGE BOX

INITIAL SETUP

Tools

Light machine repair tool kit (appendix B, section III, item 11)
Socket wrench set
Combination wrench

Materials/Parts

Plate storage box, 13226E7894

2-37. REPAIR GTO STORAGE CABINET ASSEMBLY (CONT)

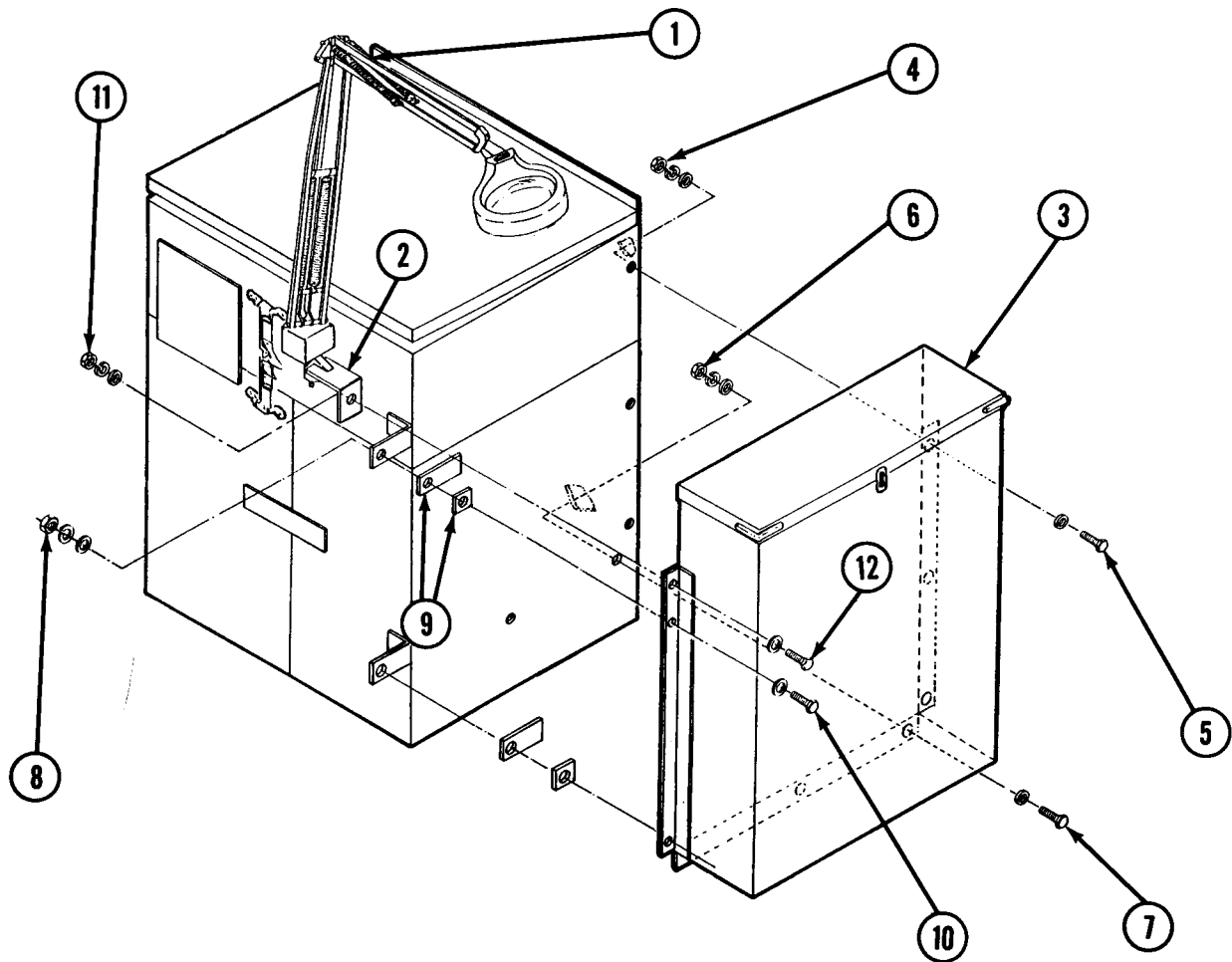

1. Lower GTO storage cabinet by turning wheel hand knobs.
2. Remove magnifier light (1) from magnifier light mounting bracket (2).
3. Remove top and bottom drawers from GTO storage cabinet.

NOTE

In steps 4 and 5, an extra person is required to hold nuts from inside cabinet.

4. At right side of plate storage box (3), remove nuts (4), lockwashers, flatwashers, and hex bolts (5).
5. At bottom of plate storage box (3), remove nuts (6), lockwashers, flatwashers, and hex bolts (7).

2-37. REPAIR GTO STORAGE CABINET ASSEMBLY (CONT)

6. At left side of plate storage box (3), remove nuts (8), lockwashers, flatwashers, spacers (9), and hex bolts (10). Remove plate storage box (3).
7. Remove nut (11), lockwasher, flatwashers, hex bolt (12), and magnifier light mounting bracket (2) from plate storage box (3).
8. Install magnifier light mounting bracket (2) with hex bolt (12), flatwashers, lockwasher, and nut (11) on new plate storage box (3).

NOTE

In the following steps, an extra person is required to hold plate storage box in position.

9. Install new plate storage box (3) with hex bolts (10), spacers (9), flatwashers, lockwashers, and nuts (8).
10. At bottom of plate storage box (3), install hex bolts (7), flatwashers, lockwashers, and nuts (6).
11. At left side of plate storage box (3), install hex bolts (5), flatwashers, lockwashers, and nuts (4).
12. Install top and bottom drawers in GTO storage cabinet.
13. Install magnifier light (1) on mounting bracket (2).
14. Turn wheel handknobs to raise GTO storage cabinet.

BRACKET ASSEMBLYINITIAL SETUPTools

Light machine repair tool kit (appendix B, section III, item 11)
 Socket wrench set
 Combination wrench
 Flat-tip screwdriver
 Pliers

Materials/Parts

Bracket assembly, 13226E7867 (2 required)

2-37. REPAIR GTO STORAGE CABINET ASSEMBLY (CONT)

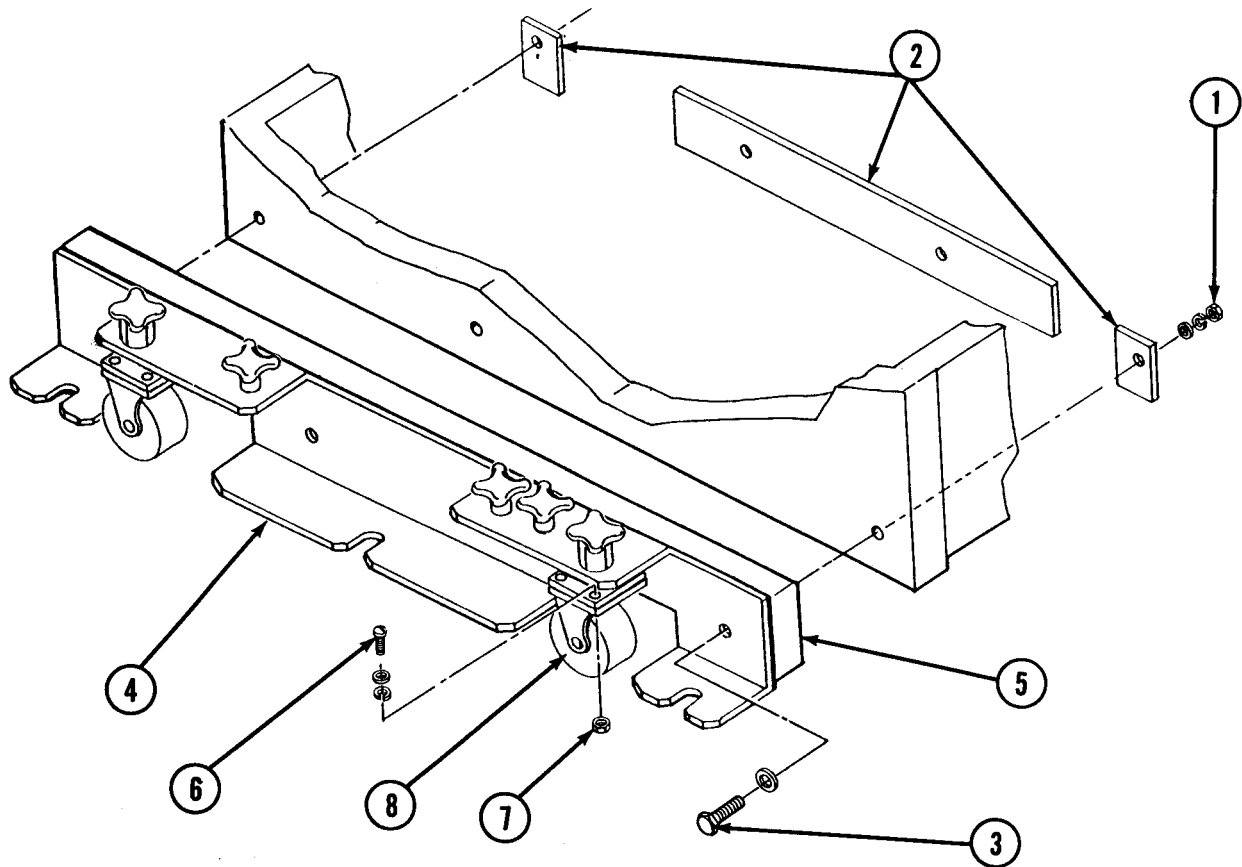

1. Remove bottom drawer from GTO storage cabinet.
2. Turn wheel handknobs to lower GTO storage cabinet to floor until pressure is released from wheels.
3. Remove nuts (1), lockwashers, flatwashers, plate stiffeners (2), and hex bolts (3) securing storage bracket (4) to GTO storage cabinet. Remove storage bracket (4) and spacer (5).
4. Remove screws (6), washers, lockwashers, nuts (7), and casters (8).
5. Install casters (8) on new storage bracket (4) with screws (6), washers, lockwashers, and nuts (7).
6. Install new storage bracket (4), spacer (5), and plate stiffeners (2) with hex bolts (3), flatwashers, lockwashers, and nuts (1).
7. Turn wheel handknobs to raise GTO storage cabinet.
8. Install bottom drawer.

2-37. REPAIR GTO STORAGE CABINET ASSEMBLY (CONT)

MAGNIFIER MOUNTING BRACKET

INITIAL SETUP

Tools

- Light machine repair tool kit (appendix B, section III, item 11)
- Socket wrench set
- Portable electric drill
- Twist drill set
- Combination wrench
- Rivet gun (appendix B, section III, item 10)

Materials/Parts

- Magnifier mounting bracket, 13227E5703
- Strap and buckle assembly, 13226E7833-1
- Strap assembly, 13226E7834-3
- Rivets, MS20600-AD6W4 (4 required)

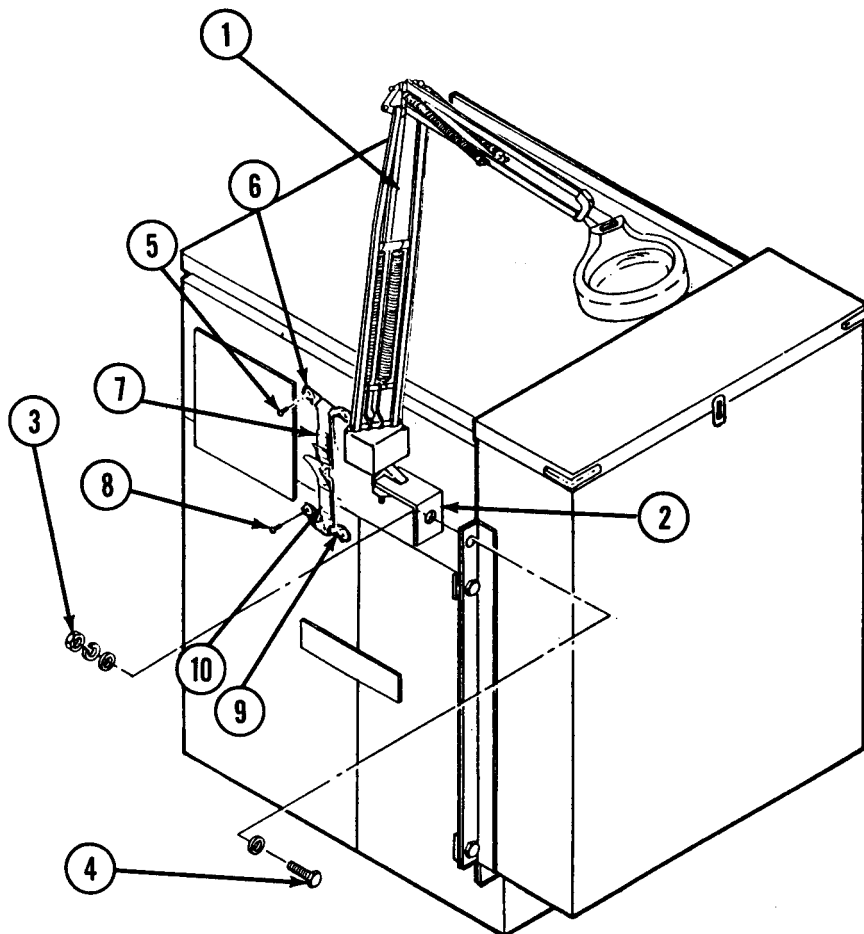

2-37. REPAIR GTO STORAGE CABINET ASSEMBLY (CONT)

1. Remove magnifier light (1) from mounting bracket (2).
2. Remove nut (3), lockwasher, flatwasher, hex bolt (4), and mounting bracket (2).
3. At rear of GTO storage cabinet, remove rivets (5) from loop strap fastener (6). Remove strap and buckle assembly (7).
4. Remove rivets (8) from loop strap fastener (9). Remove strap assembly (10).
5. Thread loop strap fastener (9) through new strap assembly (10) and install with rivets (8).
6. Thread loop strap fastener (6) through new strap and buckle assembly (7) and install with rivets (5).
7. At back of plate storage box, install mounting bracket (2) with hex bolt (4), flatwasher, lockwasher, and nut (3).
8. Install magnifier light (1) on mounting bracket (2).

2-38. REPLACE FAUCET ASSEMBLY

This task covers: a. Removal b. Installation

INITIAL SETUP

Tools

Shop equipment common no. 1 tool kit (appendix B, section III, item 12)
Pipe wrench
Adjustable wrench
Flat-tip screwdriver
Pliers

Materials/Parts

Faucet assembly, VF-T-0340-00
Close brass nipple, MS51846-20 (2 required)
PTFE tape (appendix C, item 30)

Personnel Required

Utilities Equipment Repairer 52C10

Equipment Conditions

Water tank drained (TM 5-3610-287-10, para 2-7)

2-38. REPLACE FAUCET ASSEMBLY (CONT)

REMOVAL

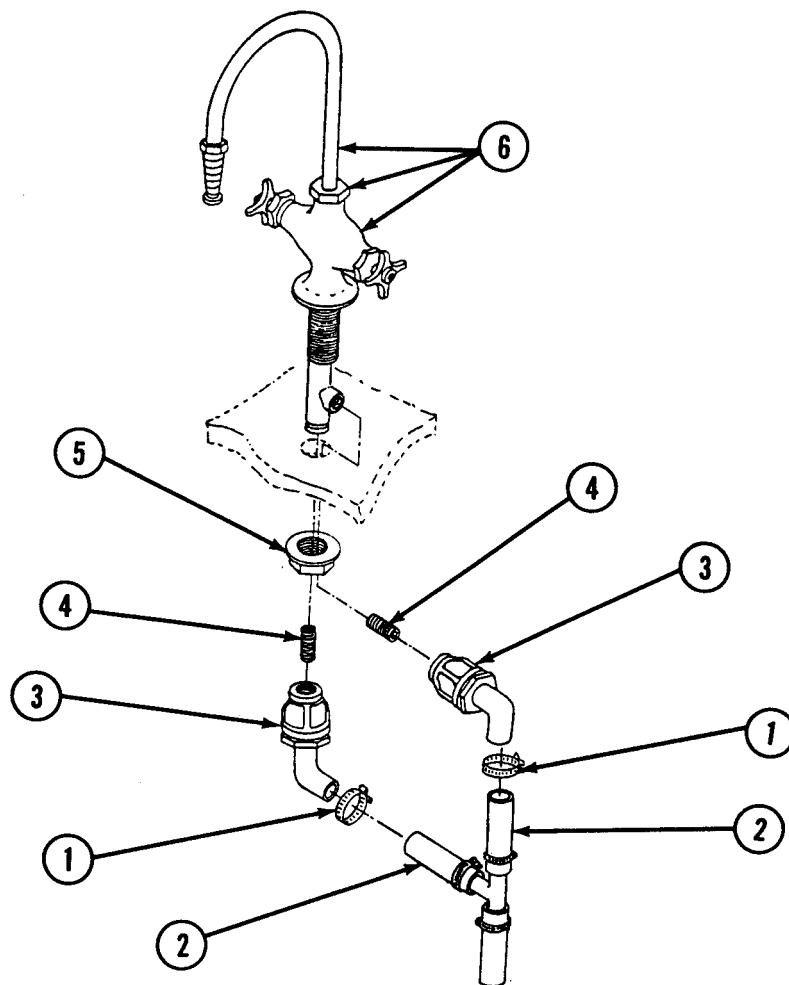
WARNING

ELECTRICAL HAZARD. Turn off power switches and circuit breakers before disconnecting electrical wiring or water lines. Failure to do so may result in death or serious injury.

1. Set WATER PUMP switch, WATER HEATER switch, and WATER HEATER AND PUMP circuit breaker to OFF.
2. Loosen clamps (1) and remove hoses (2).
3. Remove brass and plastic connectors (3).

2-38. REPLACE FAUCET ASSEMBLY (CONT)

4. Remove close brass nipples (4).

NOTE

If hex nut in following step cannot be removed because of sealing agent, remove sink from sink cabinet (para 2-40).

5. Remove hex nut (5) from faucet assembly (6).
6. Remove faucet assembly (6) from sink top.

INSTALLATION

1. Install new faucet assembly (6) in sink top.

NOTE

To prevent leakage, apply PTFE tape to all threaded water pipe connections in the following steps.

2. Install hex nut (5).
3. Install close brass nipples (4).
4. Install brass and plastic connectors (3).
5. Install hoses (2) and secure clamps (1).
6. Fill water tank (TM 5-3610-287-10, para 2-6).
7. Set WATER HEATER AND PUMP circuit breaker and WATER PUMP switch to ON.
8. Test operate water system for leaks.

2-39. REPAIR FAUCET ASSEMBLY

Faucet assembly is repaired by replacing: Replaceable seat

REPLACEABLE SEAT

INITIAL SETUP

Tools

Light machine repair tool kit (appendix B, section III, item 11)
Adjustable wrench
Flat-tip screwdriver

2-39. REPAIR FAUCET ASSEMBLY (CONT)

Materials/Parts

Replaceable seat (brass barrel)
 Rubber washers
 Rubber O-ring
 Packing washer

Equipment Conditions

Water tank drained (TM 5-3610-287-10, para 2-7)

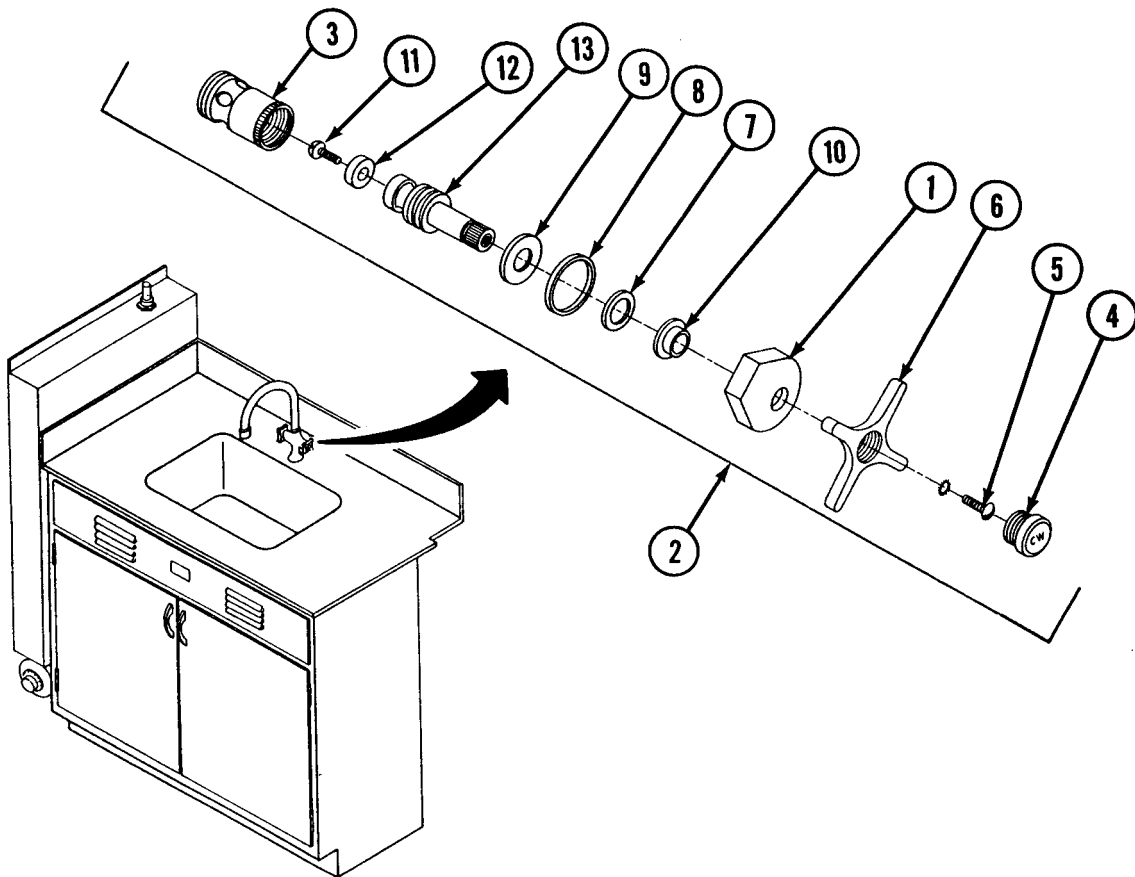

1. Set WATER PUMP switch to OFF.
2. Loosen faucet control securing nut (1).
3. Unscrew faucet control (2) and remove from faucet assembly.
4. Pull out replaceable seat (3).
5. Unscrew color-coded cover (4) and remove.

2-39. REPAIR FAUCET ASSEMBLY (CONT)

6. Remove screw (5), starwasher, and faucet handle (6).
7. Remove faucet control securing nut (1).
8. Remove brass washer (7), rubber O-ring (8), brass washer (9), and packing washer (10) from faucet control securing nut (1).
9. Remove screw (11) and rubber washer (12) from faucet stem (13).
10. Install screw (11) and new rubber washer (12) on faucet stem (13).
11. Install new packing washer (10), brass washer (9), new rubber O-ring (8), and brass washer (7) in faucet control securing nut (1).
12. Install faucet control securing nut (1) on faucet stem (13).
13. Install faucet handle (6) on stem (13) with starwasher and screw (5).
14. Install color-coded cover (4).
15. Install new replaceable seat (3).
16. Screw faucet control (2) into faucet assembly and secure with faucet control securing nut (1).
17. Fill water tank (TM 5-3610-287-10, para 2-6).
18. Set WATER PUMP switch to ON.
19. Test operate for leaks.

2-40. REPLACE SINK TOP

This task covers: a. Removal b. Installation

INITIAL SETUP

Tools

Shop equipment common no. 1 tool kit (appendix B, section III, item 12)
Cross-tip screwdriver
Flat-tip screwdriver
Pipe wrench
Adjustable wrench
Portable electric drill
Twist drill set
Scraping knife (appendix B, section III, item 9)

2-40. REPLACE SINK TOP (CONT)

Materials/Parts

- Sink top, 13227E5724
- Remote reading thermometer, 13227E6260
- Ferrule, 508K130
- Silicone compound (appendix C, item 7)
- Rubber cement (appendix C, item 6)
- Rubber cement thinner (appendix C, item 33)
- Rag (appendix C, item 24)
- PTFE tape (appendix C, item 30)

Personnel Required

Utilities Equipment Repairer 52C10

Equipment Conditions

- Faucet assembly removed (para 2-38)
- Water tank drained (TM 5-3610-287-10, para 2-7)

REMOVAL

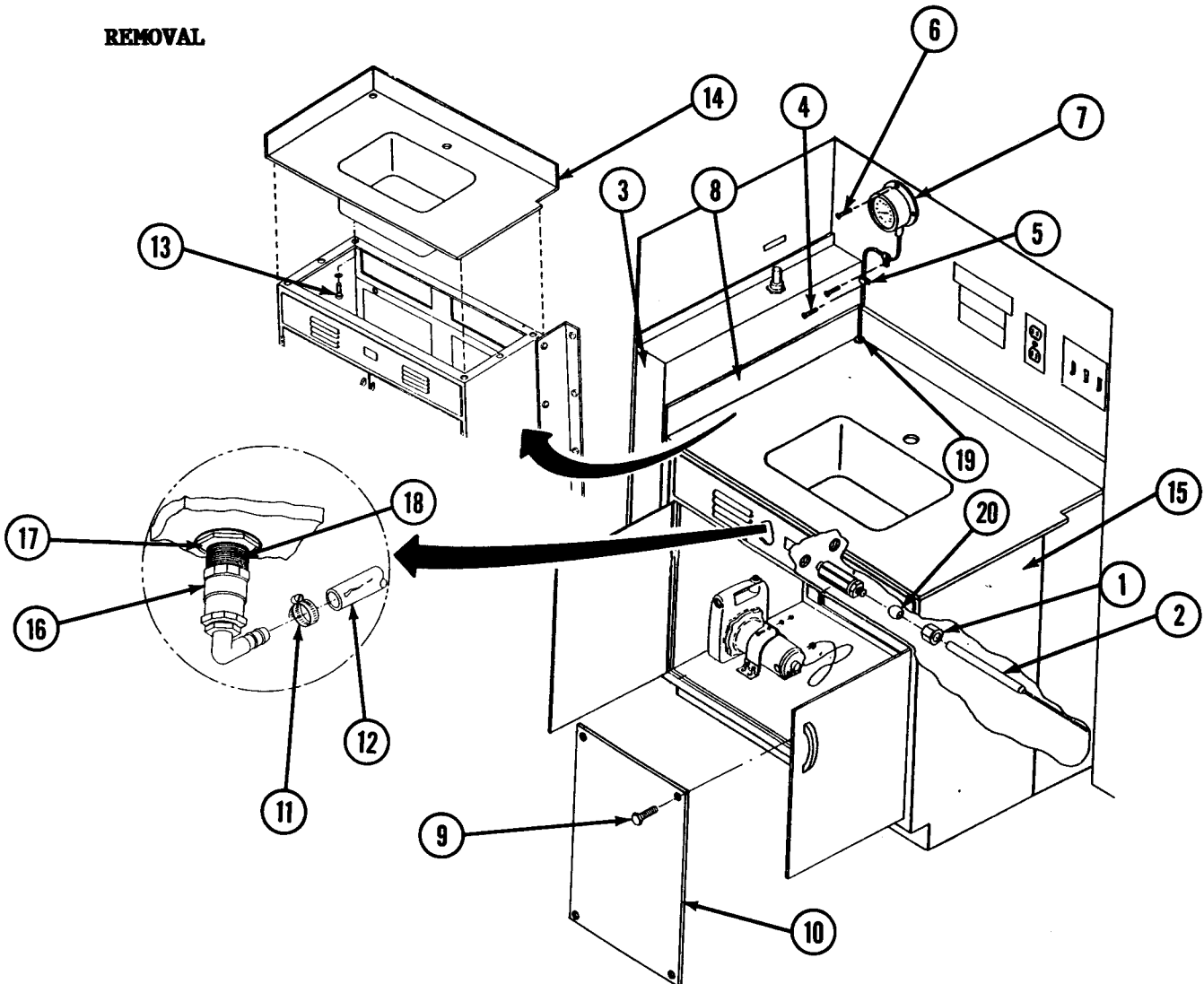

2-40. REPLACE SINK TOP (CONT)

1. Loosen B-nut (1) and remove temperature probe (2) from water tank (3).
2. Remove screws (4) and clamps (5).
3. Remove screws (6) and remote reading thermometer (7). place thermometer (7) in sink.
4. Remove rubber molding (8).
5. Remove screws (9) and panel (10).
6. Remove clamps (11) and hose (12).
7. Remove screws (13) securing sink top (14) to cabinet (15).

WARNING

Sink top weighs approximately 150 lbs (68 kg). Four people are required to lift. Do not attempt to lift by yourself. Use proper lifting techniques. Failure to observe this warning may result in personal injury.

8. Lift sink top (14) straight up and place on floor.
9. Remove plastic slipjoint connector (16), hex nut (17), and sink outlet (18) from sink top (14).
10. Remove grommet (19) from sink top (14).

NOTE

To remove remote reading thermometer, perform the following removal trials in the order given.

- a. Pull probe (2) and B-nut (1) through hole in sink top (14) and remove thermometer (7). If successful, precede to step 11.
- b. Carefully remove ferrule (20) and B-nut (1) from probe (2) and remove remote reading thermometer (7). If successful, precede to step, 11.
- c. Cut cable to remote reading thermometer and remove B-nut (1) and grommet (19). In step 12 of installation, install new remote reading thermometer (7), old grommet (19), old B-nut (1), and new ferrule (20).

2-40. REPLACE SINK TOP (CONT)**WARNING**

CHEMICAL HAZARD. Use rubber cement thinner in a well-ventilated area. Failure to do so may result in damage to respiratory system. Wear gloves and goggles to prevent injuries to skin and eyes.

11. Scrape silicone compound from splash guard. Clean off residue with rubber cement thinner.
12. Scrape rubber cement from water tank (3). Clean off residue with rubber cement thinner.

INSTALLATION**WARNING**

CHEMICAL HAZARD . Use silicone compound in a well-ventilated area. Silicone compound is harmful to eyes and skin. In case of contact with eyes, immediately flush eyes with water for 15 minutes, then seek medical help. In case of contact with skin, wipe off with dry cloth, then wash with soap and water.

1. Apply silicone compound to sink outlet (18) and install in new sink (14) with hex nuts (17).

NOTE

To prevent leakage, apply PTFE tape to all threaded pipe connections in the following steps.

2. Install plastic slipjoint connector (16).

WARNING

Sink top weighs approximately 150 lbs (68 kg). Four people are required to lift. Do not attempt to lift by yourself. Use proper lifting techniques. Failure to observe this warning may result in personal injury.

3. Lift sink top (14) and position in sink cabinet (15).
4. If necessary, drill and tap holes for screws (13). Install screws (13).
5. Install hose (12) with clamp (11).
6. Install rubber molding (8) with rubber cement.

2-40. REPLACE SINK TOP (CONT)

WARNING

CHEMICAL HAZARD. Use silicone compound in a well-ventilated area. Silicone compound is harmful to eyes and skin. In case of contact with eyes, immediately flush eyes with water for 15 minutes, then seek medical help. In case of contact with skin, wipe off with dry cloth, then wash with soap and water.

7. Seal back of sink top (14) with beads of silicone compound.
8. Install remote reading thermometer (7) with screws (6).
9. Install grommet (19) over temperature probe (2).
10. Push temperature probe (2) through hole in sink top (14).
11. Install clamps (5) with screws (4).
12. Insert grommet (19) in sink top (14).

WARNING

CHEMICAL HAZARD. Use silicone compound In a well-ventilated area. Silicone compound is harmful to eyes and skin. In case of contact with eyes, immediately flush eyes with water for 15 minutes, then seek medical help. In case of contact with skin, wipe off with dry cloth, then wash with soap and water.

13. Slide B-nut (1) and ferrule (20) on probe (2). Apply silicone compound and install probe (2) in water tank (3).
14. Install faucet assembly (para 2-38).
15. To test operate, fill water tank (TM 5-3610-287-10, para 2-6) and check for leaks.

2-41. REPLACE SINK CABINET

This task covers: a. Removal b. Installation

INITIAL SETUP

Tools

Shop equipment common no. 1 tool kit (appendix B, section III, item 12)
Flat-tip screwdriver
Socket wrench set
Magnetic retrieving tool

2-41. REPLACE SINK CABINET (CONT)Materials/Parts

Sink cabinet, 13227E5723

Personnel Required

Utilities Equipment Repairer 52C10

Equipment Conditions

Sink top removed (para 2-40)

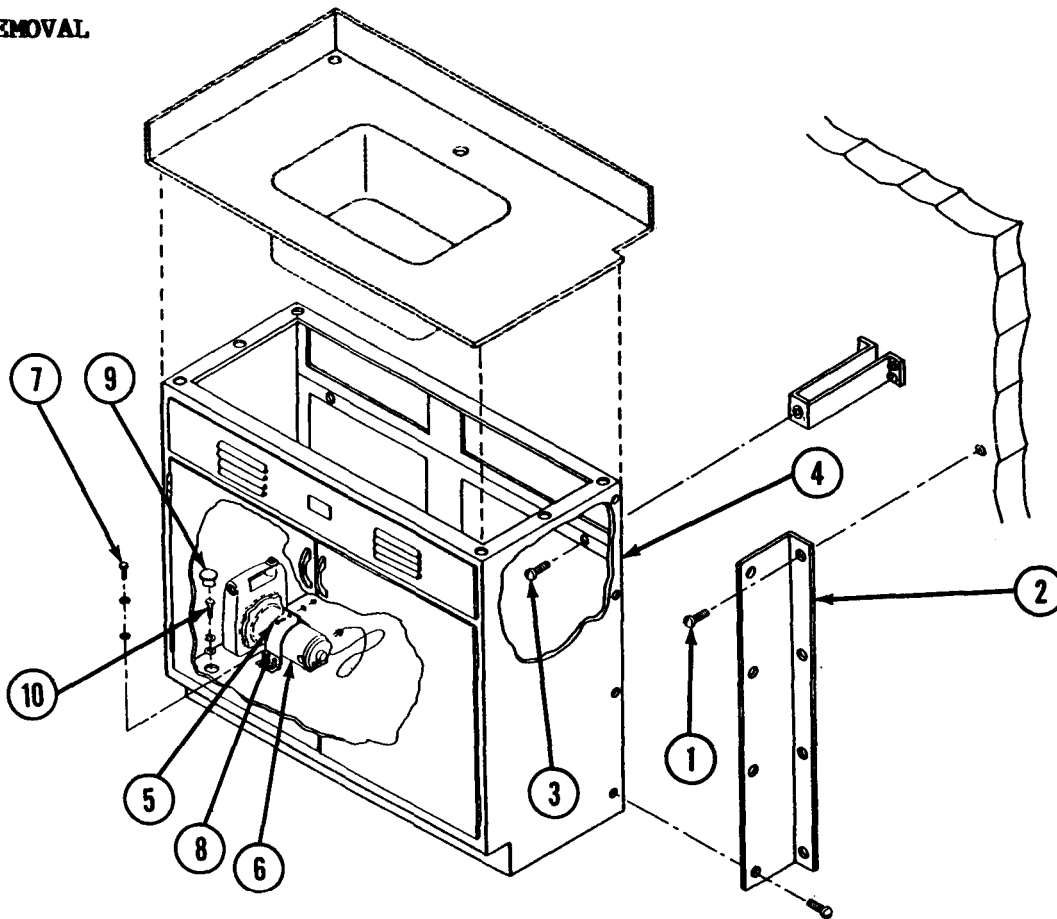
REMOVAL

1. Remove screws (1) and angle bracket (2).
2. Remove screws (3) from back of sink cabinet (4).
3. Loosen screw (5) and remove auxiliary pump (6).
4. Remove hex bolts (7), lockwashers, flatwashers, and pump mounting brackets (8).

2-41. REPLACE SINK CABINET (CONT)

5. Remove plastic covers (9) from floor of sink cabinet(4).
6. Remove lag bolts (10), lockwashers, and flatwashers.
7. Remove sink cabinet (4).

INSTALLATION

1. Position new sink cabinet (4).
2. Install lag bolts (10), lockwashers, and flatwashers.
3. Install plastic covers (9) in floor of sink cabinet (4).
4. Install screws (3) in back of sink cabinet (4).
5. Install pump mounting brackets (8) with hex bolts (7), lockwashers, and flatwashers.
6. Install auxiliary pump (6) and secure with screw (5).
7. Install angle bracket (2) with screws (1).
8. Install sink top (para 2-40).

2-42. REPAIR WATER PIPING

Water piping is repaired by replacing: a. Pressure switch b. Angle valve c. Gate valve

PRESSURE SWITCH

INITIAL SETUP

Tools

Shop equipment common no. 1 tool kit (appendix B, section III, item 12)
Pipe wrench
Flat-tip screwdriver
Cross-tip screwdriver
Extension light

Materials/Parts

Pressure switch, 13226E4449
Close nipple, MS51846-20
Wire nut, 2978
PTFE tape (appendix C, item 30)
Masking tape (appendix C, item 29)
Lead pencil (appendix C, item 13)

2-42. REPAIR WATER PIPING (CONT)

Personnel Required

Utilities Equipment Repairer 52C10

Equipment Conditions

Water tank drained (TM 5-3610-287-10, para 2-7)

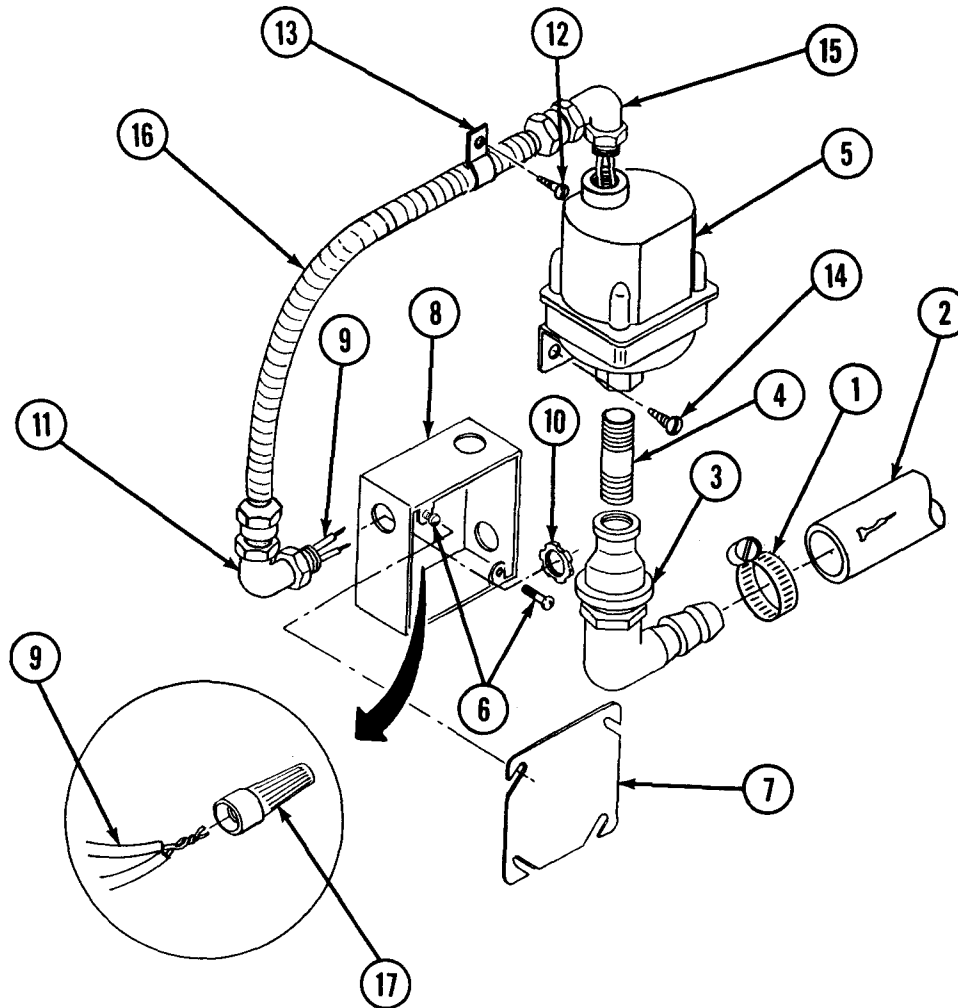

WARNING

ELECTRICAL HAZARD. Turn off main pump power switch and circuit breaker before disconnecting electric wiring or water lines. Failure to do so may result in death or serious injury.

1. Set WATER HEATER AND PUMP circuit breaker to OFF.

2-42. REPAIR WATER PIPING (CONT)

2. Loosen hose clamp (1) and remove hose (2).
3. Remove reducing adapter and elbow (3) from close nipple (4).
4. Remove close nipple (4) from pressure switch (5).
5. Loosen screws (6) and remove cover plate (7) from junction box (8).
6. Tag and disconnect wires (9) leading from pressure switch (5).
7. Remove segmented locknut (10) and strain relief (11).
8. Remove screw (12) and clamp (13) from wall.
9. Remove screws (14) and pressure switch (5) from wall.
10. Unscrew strain relief (15) and pull wires (9) from conduit (16).

NOTE

To prevent leakage, apply PTFE tape on all threaded water pipe connections in the following steps.

11. Thread wiring (9) through conduit (16).
12. Screw strain relief (15) into pressure switch (5).
13. Install new pressure switch (5) with screws (14).
14. Install clamp (13) with screw (12).
15. Install strain relief (11) with segmented locknut (10).
16. Connect wires (9) with wire nuts (17).
17. Install cover plate (7) with screws (6).
18. Install new close nipple (4) in pressure switch (5).
19. Install reducing adapter and elbow (3) on close nipple (4).
20. Install hose (2) with hose clamp (1).
21. To test operate, fill water tank (TM 5-3610-287-10, para 2-6) and check for leaks and proper operation of water pump.

2-42. REPAIR WATER PIPING (CONT)

ANGLE VALVE

INITIAL SETUP

Tools

Shop equipment common no. 1 tool kit (appendix B, section III, item 12)
Adjustable wrench
Extension light

Materials/Parts

Angle valve, 7-701
PTFE tape (appendix C, item 30)

Personnel Required

Utilities Equipment Repairer 52C10

Equipment Conditions

Water tank drained (TM 5-3610-287-10, para 2-7)

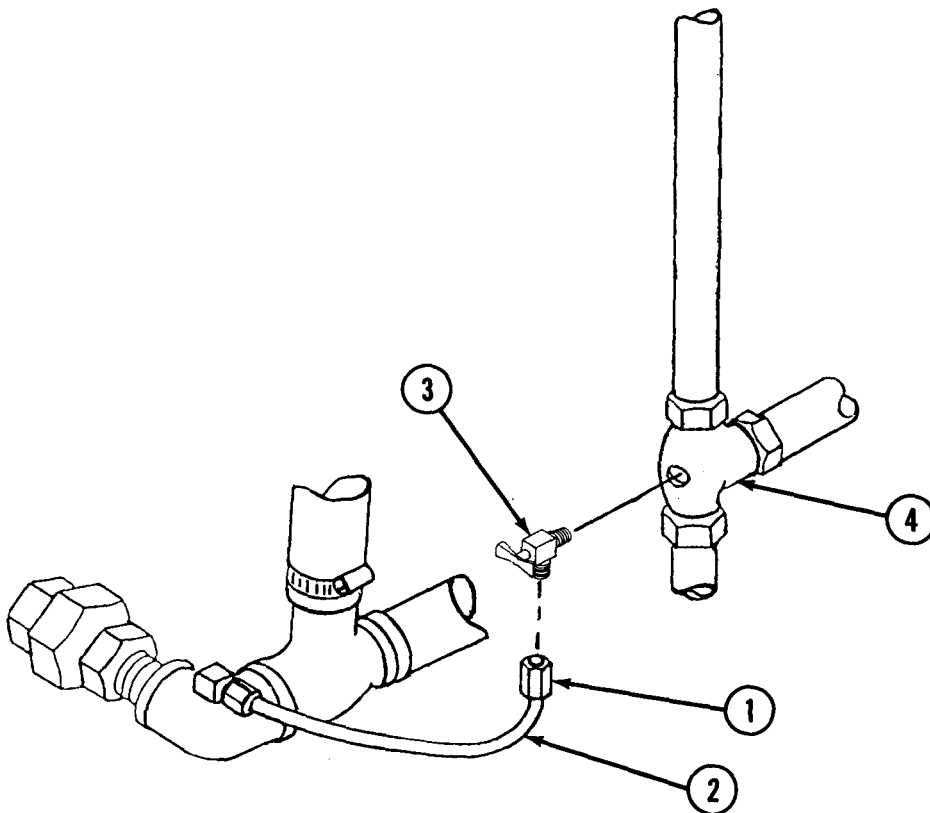

2-42. REPAIR WATER PIPING (CONT)

1. Loosen B-nut (1) and remove tubing (2).
2. Remove angle valve (3) from check valve (4).

NOTE

To prevent leakage, apply PTFE tape to all threaded pipe connections in the following steps.

3. Install new angle valve (3) into old check valve (4).
4. Position tubing (2) and tighten B-nut (1).
5. Turn angle valve (3) to right.
6. To test operate, fill water tank (TM 5-3610-287-10, para 2-6) and check for leaks.

GATE VALVE

INITIAL SETUP

Tools

Shop equipment common no. 1 tool kit (appendix B, section III, item 12)
Pipe wrench
Flat-tip screwdriver
Extension light

Materials/Parts

Gate valve, 424-1
Close nipple, 4830K221
PTFE tape (appendix C, item 30)

Personnel Required

Utilities Equipment Repairer 52C10

Equipment Conditions

Water tank drained (TM 5-3610-287-10, para 2-7)

2-42. REPAIR WATER PIPING (CONT)

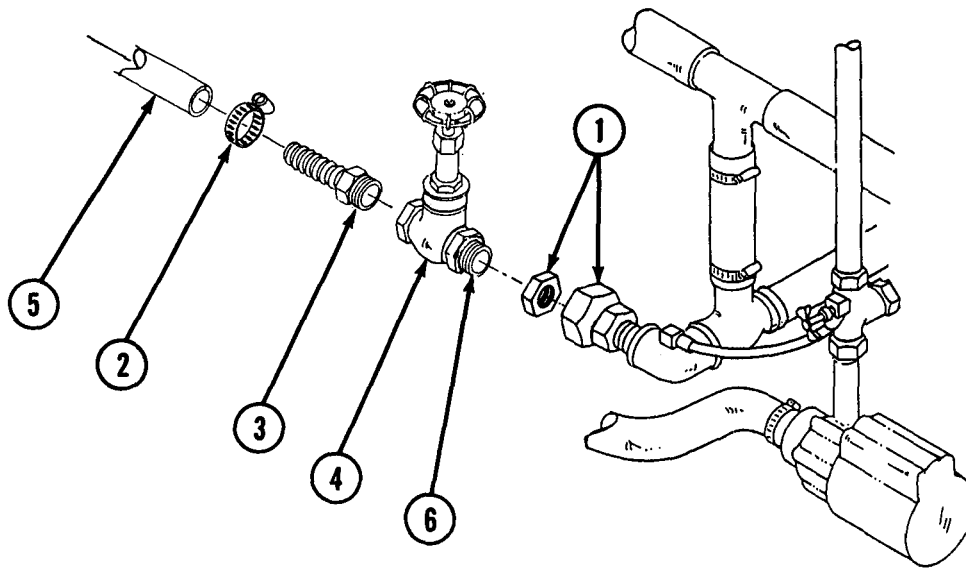

1. Loosen pipe union (1).
2. Loosen hose clamp (2) and remove nylon adapter (3) with gate valve (4) from hose (5).
3. Remove nylon adapter (3) from gate valve (4).

NOTE

To prevent leakage, apply PTFE tape on all threaded pipe connections in the following steps.

4. Remove union (1) from gate valve (4).
5. Install new close nipple (6) in new gate valve (4).
6. Install union (1) on close nipple (6).
7. Install nylon adapter (3) in new gate valve (4).

2-42. REPAIR WATER PIPING (CONT)

8. Install nylon adapter (3) with gate valve (4) in hose (5). Secure clamp (2).
9. Tighten union (1).
10. To test operate, fill water tank (TM 5-3610-287-10, para 2-6) and check for leaks.

2-43. REPLACE MAIN PUMP

This task covers: a. Removal b. Installation

INITIAL SETUP

Tools

Shop equipment common no. 1 tool kit (appendix B, section III, item 12)
Flat-tip screwdriver
Cross-tip screwdriver
Adjustable wrench
Pliers
Extension light

Materials/Parts

Main pump, AC-5C-MD
Wire nuts, 2978
PTFE tape (appendix C, item 30)

Personnel Required

Utilities Equipment Repairer 52C10

Equipment Conditions

Water tank drained (TM 5-3610-287-10, para 2-7)

2-43. REPLACE MAIN PUMP (CONT)

REMOVAL

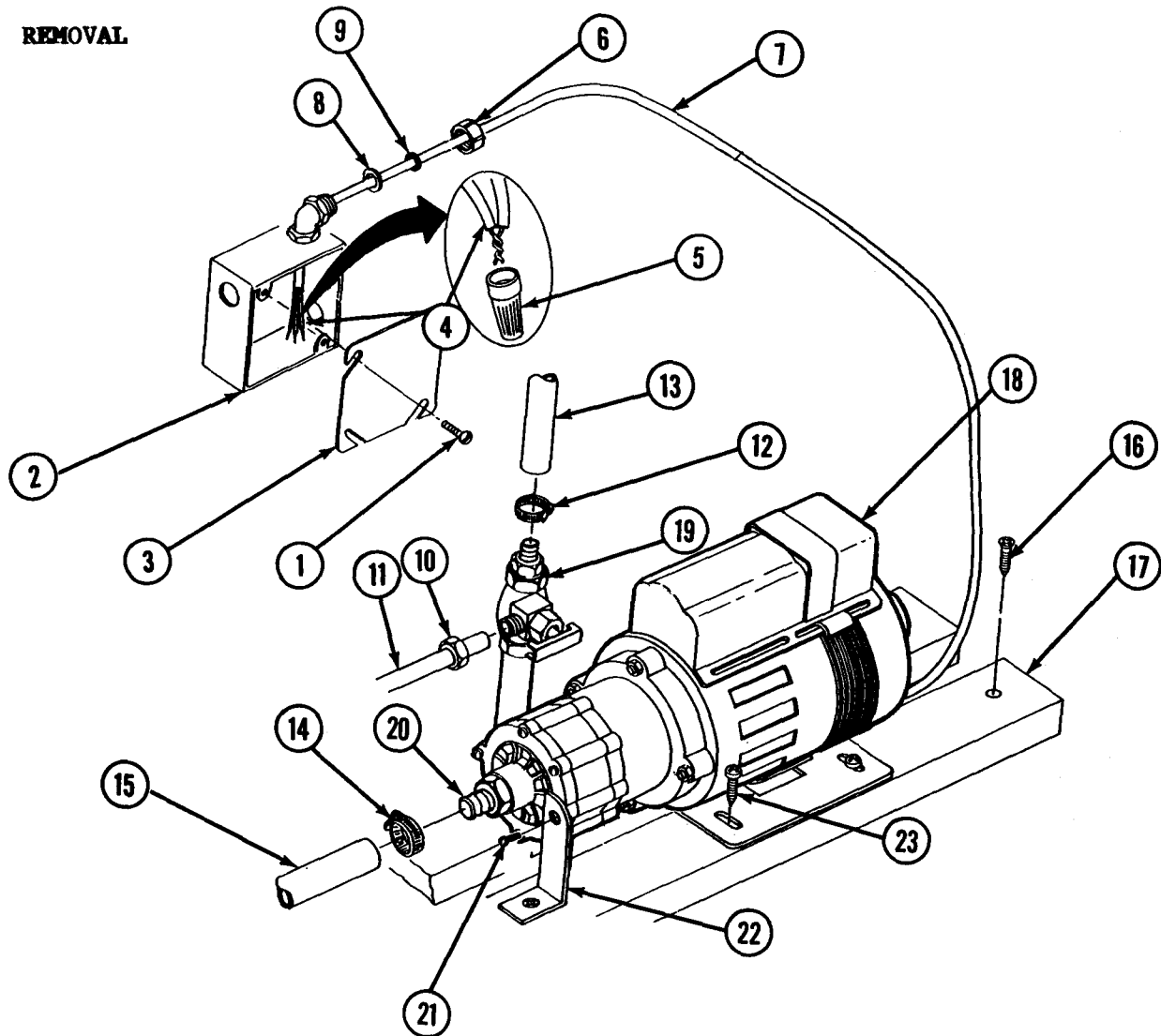

WARNING

ELECTRICAL HAZARD. Turn off power switches and circuit breaker before disconnecting electrical wiring or water lines. Failure to do so may result in death or serious injury.

1. Set WATER HEATER and WATER PUMP switches and WATER HEATER AND PUMP circuit breaker to OFF.
2. Loosen screws (1) on electrical box (2) and remove cover plate (3).
3. Tag wires (4) from main pump and disconnect by removing wire nuts (5).
4. Remove jam nut (6) and pull power cord (7) from electrical box (2).

2-43. REPLACE MAIN PUMP (CONT)

5. Remove washer (8), grommet (9), and jam nut (6) from power cord (7).
6. Loosen B-nut (10) and remove tubing (11).
7. Remove clamp (12) and hose (13).
8. Remove clamp (14) and hose (15).
9. Remove screws (16) securing main pump mounting blocks (17) to floor.
10. Remove main pump (18).
11. Remove check valve (19) from main pump (18).
12. Remove nylon adapter (20).
13. Remove screw (21) securing water pump bracket (22) to main pump (18).
14. Remove screws (23) securing main pump (18) to mounting blocks (17).

INSTALLATION

NOTE

To prevent leakage, apply PTFE tape to all threaded pipe connections in the following steps.

1. Install new main pump (18) on mounting blocks (17) with screws (23). Snug, but do not tighten screws (23).
2. Install mounting bracket (22) with screws (21).
3. Install check valve (19) on main pump (18).
4. Install nylon adapter (20) to main pump (18).
5. Position main pump (18) behind sink cabinet and secure to floor with screws (16). Tighten screws (23).
6. Install hose (15) with clamp (14).
7. Install hose (13) with clamp (12).
8. Install tubing (11) with B-nut (10).
9. Install jam nut (6), grommet (9), and washer (8) on new power cord (7).
10. Install power cord (7) to electrical box (2) with jam nut (6).

2-43. REPLACE MAIN PUMP (CONT)

11. Connect wires (4) with wire nuts (5).
12. Install cover plate (3) with screws (1).
13. Set WATER HEATER AND PUMP circuit breaker to ON.
14. To test operate pump, fill water tank (TM 5-3610-287-10, para 2-6) and check for leaks.

2-44. REPAIR WATER TANK ASSEMBLY

Water tank assembly is repaired by replacing: a. Immersion heater
b. Liquid level gage c. Remote reading thermometer d. Water tank

IMMERSION HEATER

INITIAL SETUP

Tools

Shop equipment common no. 1 tool kit (appendix B, section III, item 12)
Flat-tip screwdriver
Combination wrench set
Socket wrench set

Materials/Parts

Immersion heater, 13227E6258
Gasket, 13226E7973
PTFE tape (appendix C, item 30)
Masking tape (appendix C, item 29)
Lead pencil (appendix C, item 13)

Personnel Required

Utilities Equipment Repairer 52C10

Equipment Conditions

Water tank drained (TM 5-3610-287-10, para 2-7)

2-44. REPAIR WATER TANK ASSEMBLY (CONT)

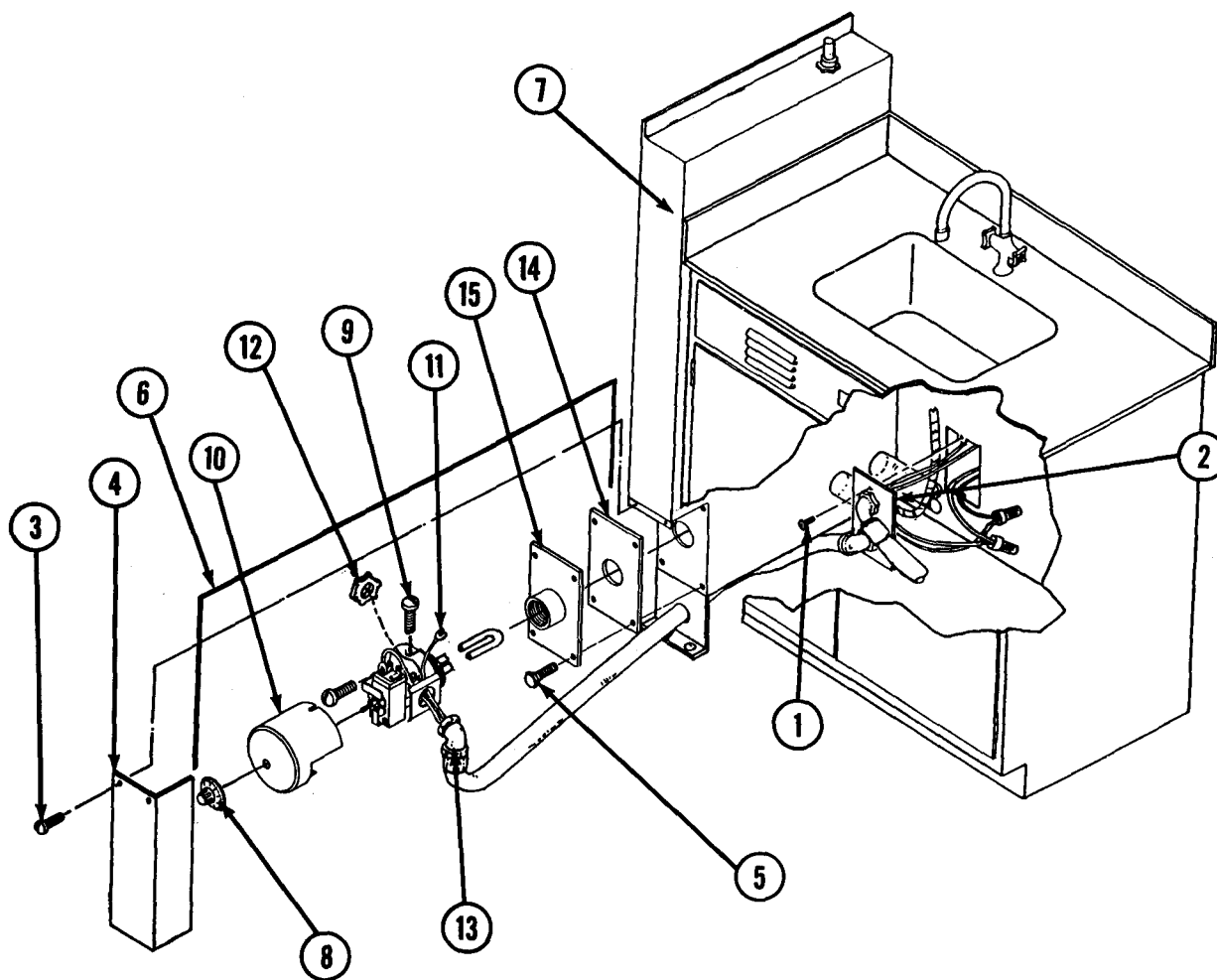

WARNING

ELECTRICAL HAZARD. Turn off power switches and circuit breakers before disconnecting electrical wiring or water lines. Failure to do so may result in death or serious injury.

1. Set WATER PUMP switch, WATER HEATER switch, and WATER HEATER AND PUMP circuit breakers to OFF.
2. Remove screws (1) and wall plate (2).
3. Remove screws (3) and cover plate (4).
4. Remove hex bolts (5) and pull immersion heater (6) from water tank (7).

2-44. REPAIR WATER TANK ASSEMBLY (CONT)

5. Remove knob (8). Loosen screws (9) and remove cover (10).
6. Tag and remove wiring (11).
7. Remove segmented locknut (12) and pull strain relief (13) from immersion heater (6).
8. Remove gasket (14) and coupling flange (15).
9. Apply PTFE tape to pipe threads on new immersion heater. Install coupling flange (15) and gasket (14) on new immersion heater (6).
10. Install strain relief (13) with segmented locknut (12).
11. Connect wiring (11).
12. Install cover (10) and tighten screws (9).
13. Install knob (8).
14. Install immersion heater (6) in water tank (7) with hex bolts (5).
15. Install wall plate (2) with screws (1).
16. To test operate, fill water tank (TM 5-3610-287-10, para 2-6). Set knob (4) to desired temperature. Observe until thermometer stabilizes. Check for leaks.
17. Install cover plate (4) with screws (3).

LIQUID LEVEL GAGE

INITIAL SETUP

Tools

Shop equipment common no. 1 tool kit (appendix B, section III, item 12)
Pipe wrench

Materials/Parts

Liquid level gage, 13227E6257
PTFE tape (appendix C, item 30)
Lead pencil (appendix C, item 13)

Personnel Required

Utilities Equipment Repairer 52C10

2-44. REPAIR WATER TANK ASSEMBLY (CONT)

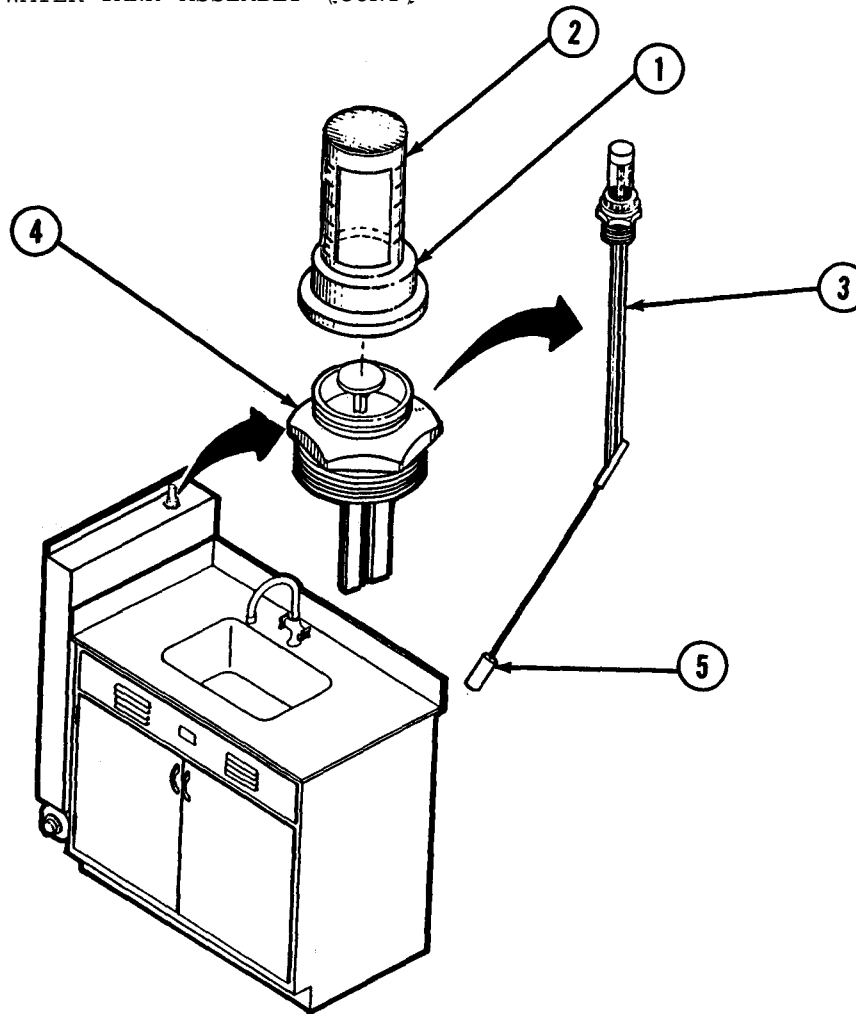

1. Remove plastic nut (1) and plastic sight gage (2).
2. Remove liquid level gage (3) by loosening hex nut (4).

NOTE

Ensure cork arm is facing heater end of water tank when installed.

3. Mark position of cork arm (5) on face of hex nut (4) on new liquid level gage (3).
4. Apply PTFE tape to pipe threads and install liquid level gage (3) with hex nut (4). Ensure mark on hex nut points toward heater end of tank.
5. Install plastic sight gage (2) and plastic nut (1).
6. To test operate, fill water tank (TM 5-3610-287-10, para 2-6) and observe gage for proper operation.

2-44. REPAIR WATER TANK ASSEMBLY (CONT)

REMOTE READING THERMOMETER

INITIAL SETUP

Tools

Shop equipment common no. 1 tool kit (appendix B, section III, item 12)
Adjustable wrench
Cross-tip screwdriver
File
Pliers (appendix B, section III, item 15)

Materials/Parts

Remote reading thermometer, 13227E6260
Ferrule, 508K130

Personnel Required

Utilities Equipment Repairer 52C10

Equipment Conditions

Water tank drained (TM 5-3610-287-10, para 2-7)

2-44. REPAIR WATER TANK ASSEMBLY (CONT)

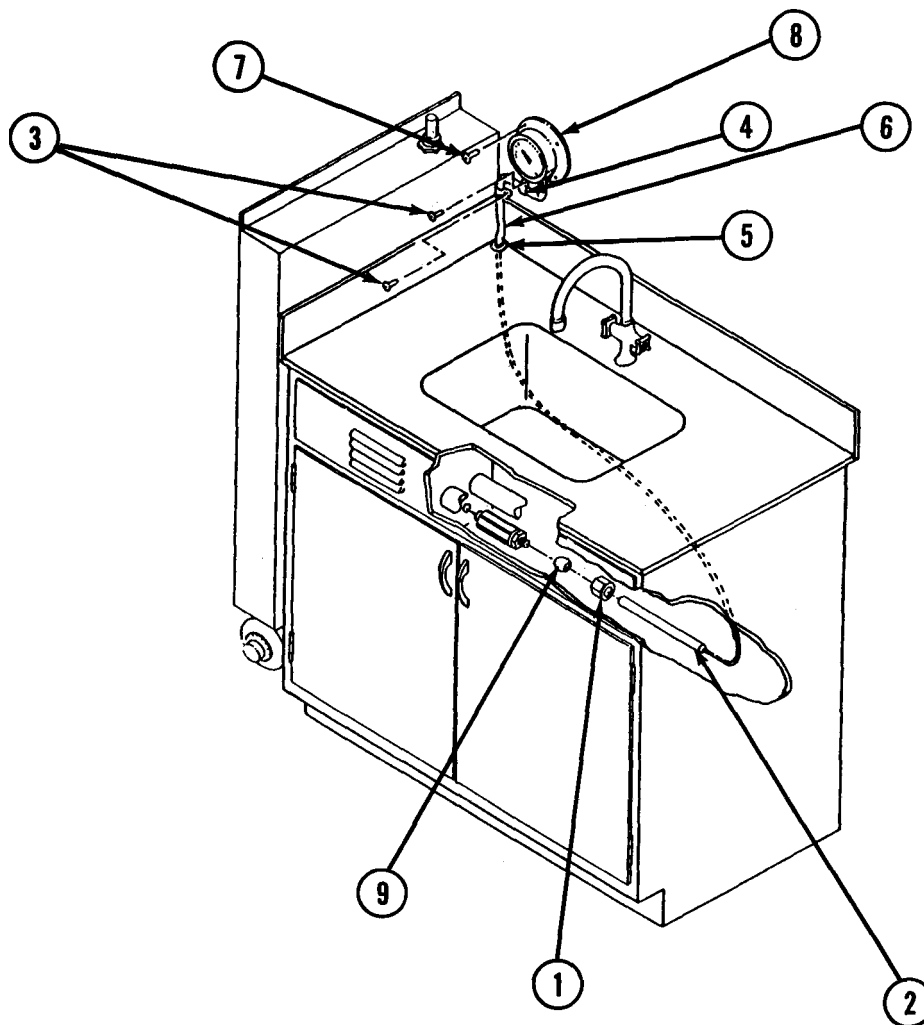

1. Loosen B-nut (1) and remove probe (2).
2. Remove screws (3) and cable clamps (4).
3. Remove grommet (5).
4. Pull thermometer cable (6) through hole in sink top and remove B-nut (1). If hole in sink top is too small, cut cable (6).
5. Remove screws (7) and remove reading thermometer (8).
6. If it was necessary to cut thermometer cable, enlarge hole in sink top for B-nut.
7. Install new remote reading thermometer (8) with screws (7).

2-44. REPAIR WATER TANK ASSEMBLY (CONT)

8. Install grommet (5) on thermometer cable (6).
9. Run thermometer cable (6) through hole in sink top.
10. Install grommet (5) in sink top.
11. Install cable clamps (4) with screws (3).

WARNING

CHEMICAL HAZARD. Use silicone compound in a well-ventilated area. Silicone compound is harmful to eyes and skin. In case of contact with eyes, immediately flush eyes with water for 15 minutes, then seek medical help. In case of contact with skin, wipe off with dry cloth, then wash with soap and water.

12. Slide B-nut (1) and ferrule (9) on probe (2). Apply silicone compound to ferrule.

CAUTION

Do not overtighten B-nut. Excessive pressure from ferrule will damage probe.

13. Install probe (2) in water tank and tighten B-nut (1).
14. To test operate, fill water tank (TM 5-3610-287-10, para 2-6).

WATER TANK

INITIAL SETUP

Tools

Shop equipment common no. 1 tool kit (appendix B, section III, item 12)
 Cross-tip screwdriver
 Socket wrench set
 Pipe wrench
 Adjustable wrench
 Flat-tip screwdriver

Materials/Parts

Water tank, 13226E7901
 Silicone compound (appendix C, item 7)
 Rubber cement (appendix C, item 6)
 Rubber cement thinner (appendix C, item 33)
 Rag (appendix C, item 24)
 PTFE tape (appendix C, item 30)

2-44. REPAIR WATER TANK ASSEMBLY (CONT)

Personnel Required

Utilities Equipment Repairer 52C10

Equipment Conditions

Immersion heater removed (a, this para)
Liquid level gage removed (b, this para)

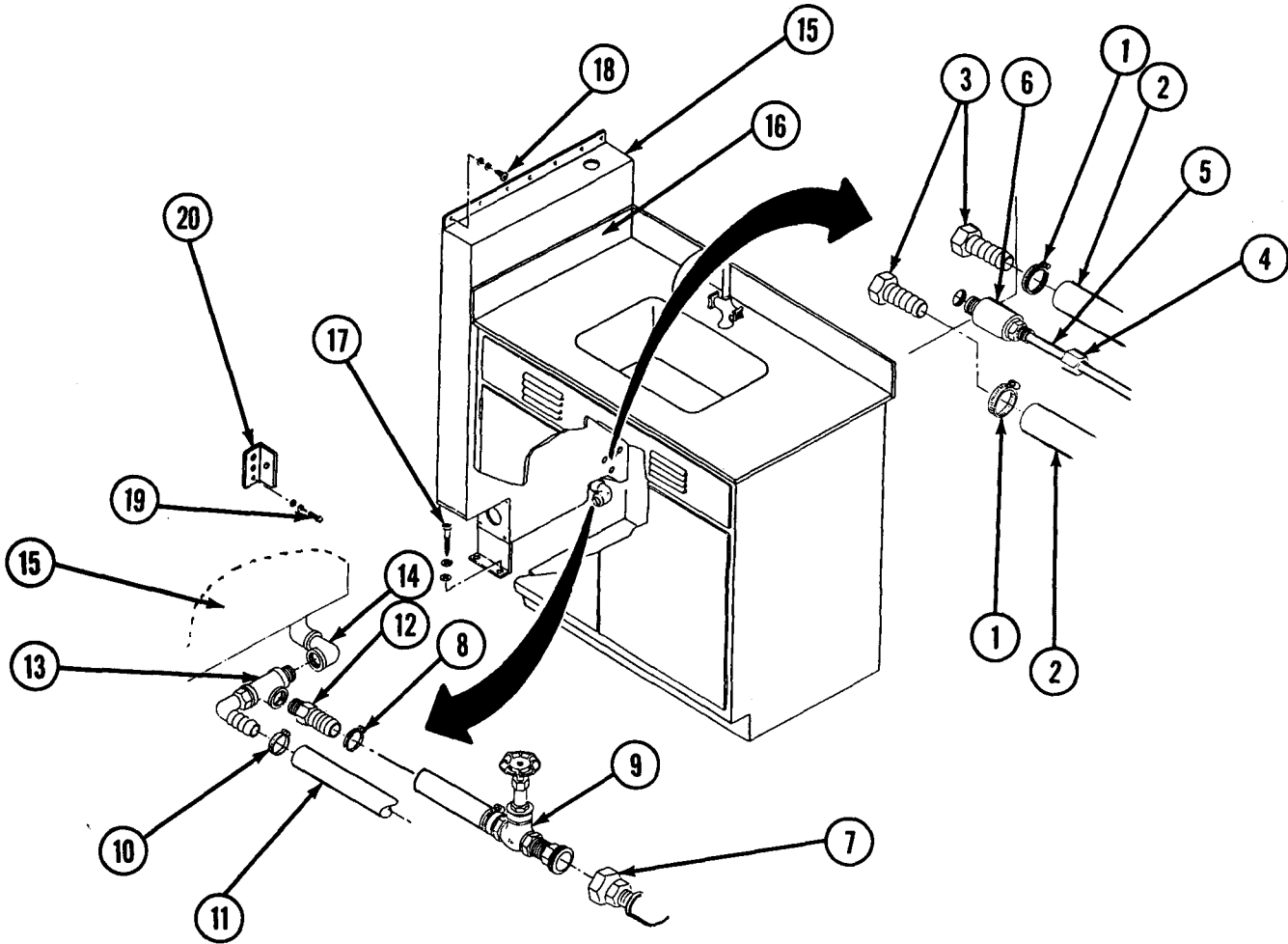

1. Remove pile boards from feeder board storage rack.
2. Loosen hose clamps (1) and remove hoses (2).
3. Remove nylon adapters (3).
4. Loosen B-nut (4) and remove remote reading thermometer probe (5).

2-44. REPAIR WATER TANK ASSEMBLY (CONT)

5. Remove pipe coupling with copper fitting (6).
6. Loosen union (7) and clamp (8), then remove gate valve assembly (9).
7. Loosen clamp (10) and remove hose (11).
8. Remove nylon adapter (12).
9. Remove T-assembly (13).
10. Push elbows (14) under water tank (15).
11. Remove rubber molding (16).
12. Remove lag bolts (17), lockwashers, and flatwashers.
13. Remove screws (18).
14. Remove screws (19), lockwashers, flatwashers, and feeder board locking bracket (20).
15. Pull top of water tank (15) toward jogging table and into feeder board storage rack. Pull water tank (15) out enough to clear sink assembly and remove.
16. Remove elbows (14) from water tank (15).

NOTE

To prevent leakage, apply PTFE tape to all threaded pipe connections in the following steps.

17. Install elbows (14) on new water tank (15).
18. Position water tank (15) in feeder board storage rack and slide toward sink. Lift into position.
19. Install screws (18).
20. Install lag bolts (17), lockwashers, and flatwashers.
21. Install feeder board locking bracket (20) with screws (19), lockwashers, and flatwashers.

2-44. REPAIR WATER TANK ASSEMBLY (CONT)

WARNING

CHEMICAL HAZARD. Use rubber cement thinner in a well-ventilated area. Failure to do so may result in damage to respiratory system. Wear gloves and goggles to prevent injuries to skin and eyes.

22. Clean rubber cement from back of rubber molding (16) with rag and rubber cement thinner.
23. Spread rubber cement on rubber molding (16) and install on water tank (15).
24. Pull elbows (14) from under water tank (15) and position.
25. Install T-assembly (13).
26. Install nylon adapter (12).
27. Install hose (11) with clamp (10).
28. Install gate valve assembly (9) with clamp (8). Tighten union (7).
29. Install coupling with copper fitting (6).

WARNING

CHEMICAL HAZARD. Use silicone compound in a well-ventilated area. Silicone compound is harmful to eyes and skin. In case of contact with eyes, immediately flush eyes with water for 15 minutes, then seek medical help. In case of contact with skin, wipe off with dry cloth, then wash with soap and water.

30. Apply silicone compound to ferrule on probe (5) and install with B-nut (4).
31. Install nylon adapters (3).
32. Install hoses (2) with clamps (1).
33. Install pile boards in feeder board storage rack and secure locking bar.
34. Install immersion heater and liquid level gage (para 2-44).

2-45. REPLACE WATER BOX ASSEMBLY

This task covers: a. Removal b. Installation

INITIAL SETUP

Tools

Shop equipment common no. 1 tool kit (appendix B, section III, item 12)
Adjustable wrench
Pipe wrench
Flat-tip screwdriver
Scraping knife (appendix B, section III, item 9)

Materials/Parts

Water box assembly, 13226E7874
PTFE tape (appendix C, item 30)
Silicone compound (appendix C, item 7)
Rubber cement thinner (appendix C, item 33)
Rag (appendix C, item 24)

Personnel Required

Utilities Equipment Repairer 52C10

Equipment Conditions

Water tank drained (TM 5-3610-287-10, para 2-7)

2-45. REPLACE WATER BOX ASSEMBLY (CONT)

REMOVAL

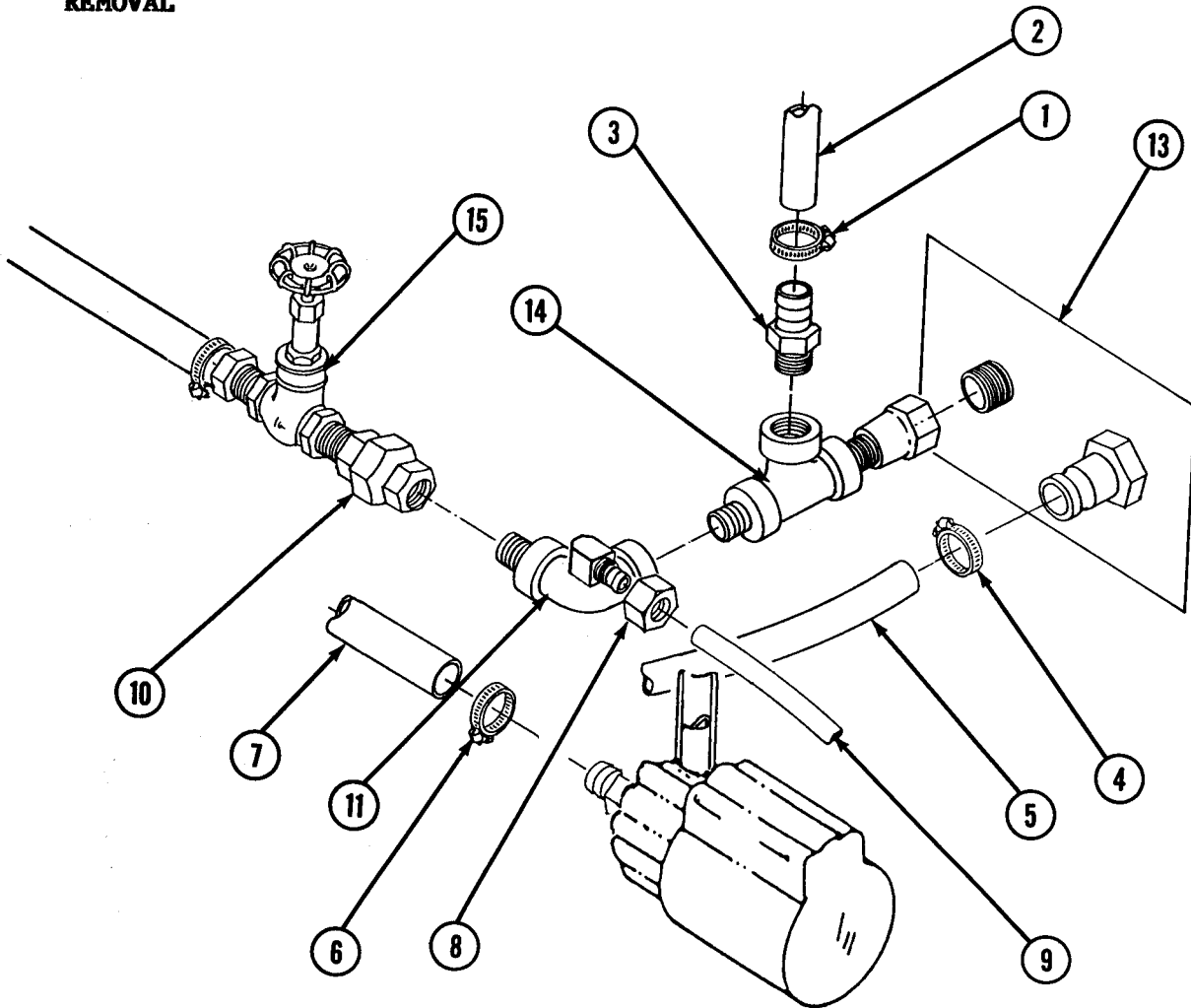

1. Set WATER HEATER and WATER PUMP switches to OFF.
2. Loosen hose clamps (1) and remove hose (2).
3. Remove nylon adapter (3).
4. Remove clamp (4) and hose (5).
5. Remove clamp (6) and hose (7).
6. Loosen B-nut (8) and remove tubing (9).
7. Loosen pipe union (10), then remove from elbow (11).

2-45. REPLACE WATER BOX ASSEMBLY (CONT)

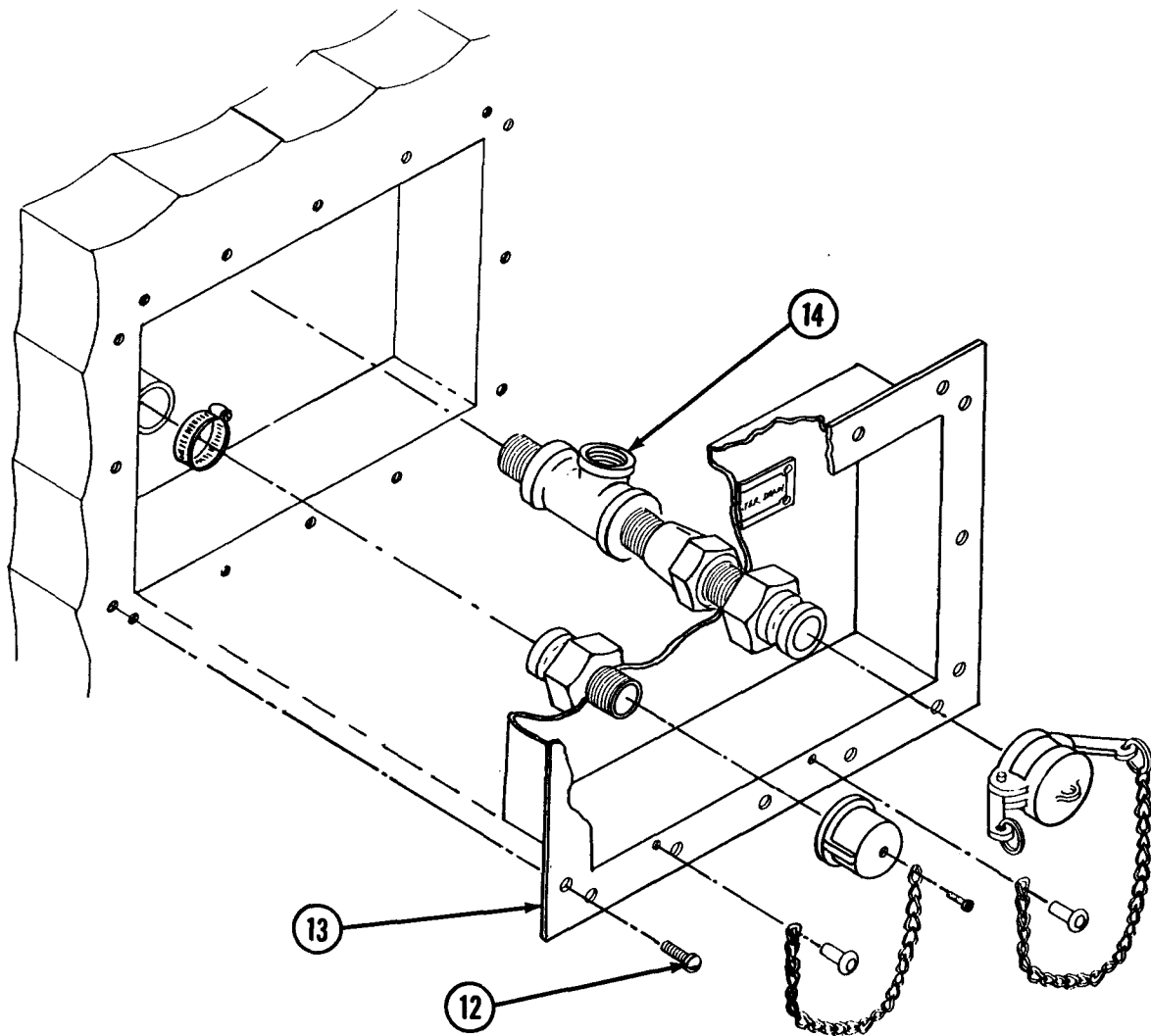

8. Outside Section, remove screws (12).
9. With scraping knife, cut through silicone compound between water box assembly (13) and Section body.
10. Inside Section, tilt piping up and remove elbow (11).
11. Outside Section, pull water box assembly (13) and piping (14) from Section body.

2-45. REPLACE WATER BOX ASSEMBLY (CONT)

WARNING

CHEMICAL HAZARD. Use rubber cement thinner in a well-ventilated area. Failure to do so may result in damage to respiratory system. Wear gloves and goggles to prevent injuries to skin and eyes.

12. Scrape silicone compound from Section body and remove residue with rubber cement thinner.
13. Remove piping (14) from water box assembly (13).

INSTALLATION

NOTE

To prevent leakage, apply PTFE tape to all threaded pipe connections in the following steps.

1. Install piping (14) on new water box assembly (13).
2. Position water box assembly (13) in Section body.
3. Tilt piping (14) up and install elbow (11).

WARNING

CHEMICAL HAZARD. Use silicone compound in a well-ventilated area. Silicone compound is harmful to eyes and skin. In case of contact with eyes, immediately flush eyes with water for 15 minutes, then seek medical help. In case of contact with skin, wipe off with dry cloth, then wash with soap and water.

4. Spread silicone compound on flanged area of water box assembly (13) and secure with screws (12).
5. Install union (10) on elbow (11), then secure to gate valve (15).
6. Install tubing (9) and tighten B-nut (8).
7. Install hose (7) and tighten hose clamp (6).
8. Install nylon adapter (3).
9. Install hose (2) and tighten hose clamp (1).

2-45. REPLACE WATER BOX ASSEMBLY (CONT)

10. Install hose (5) and tighten hose clamp (4).
11. To test operate, fill water tank (TM 5-3610-287-10, para 2-6) and check for leaks.

2-46. REPAIR WATER BOX ASSEMBLY

Water box assembly is repaired by replacing: Pipe caps and chain

PIPE CAPS AND CHAIN

INITIAL SETUP

Tools

Light machine repair tool kit (appendix B, section III, item 11)
Hammer
Chisel
Punch
Rivet gun (appendix B, section III, item 10)

Materials/Parts

Dust cap, MS27028-6
Pipe cap, 13226E7807
Blind rivet, MS20600-MP4W6 (3 required)
Copper 7" chain, RR-C-271 (2 required)

2-46. REPAIR WATER BOX ASSEMBLY (CONT)

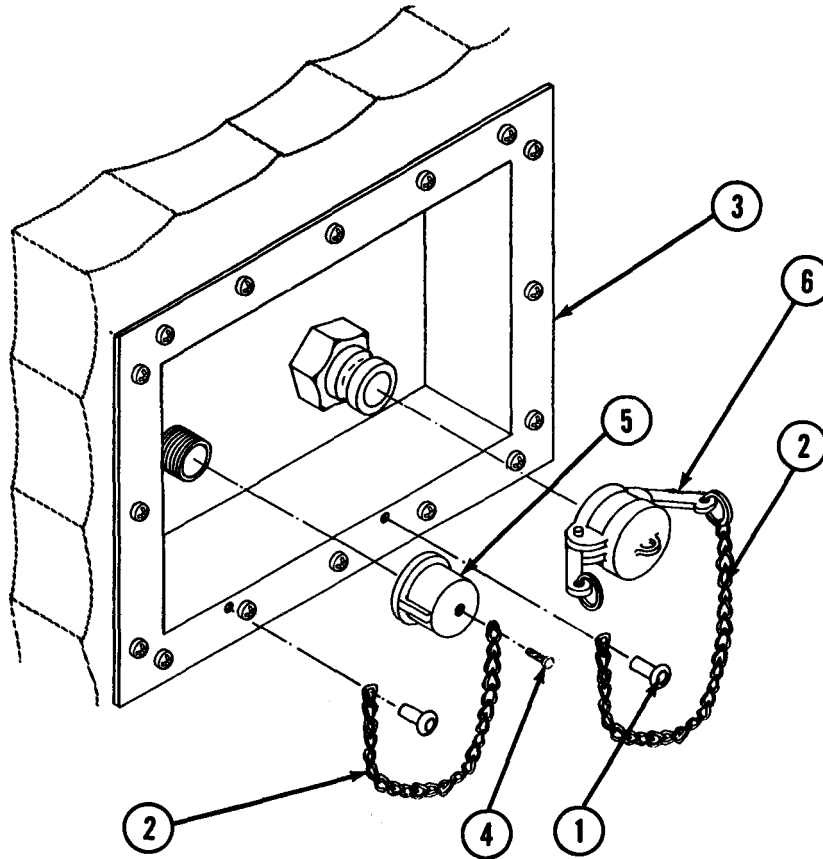

1. Remove rivets (1) and separate chains (2) from water box assembly (3).
2. Remove rivet (4) and separate chain (2) from pipe cap (5).
3. Remove chain (2) from dust cap (6).
4. Install new chains (2) on water box assembly (3) with rivets (1).
5. Install chain (2) on pipe cap (5) with rivet (4).
6. Install chain (2) on dust cap (6).

2-47. REPAIR TELEPHONE INSTALLATION

Telephone installation is repaired by replacing: a. Outside cover
 b. Exterior binding posts c. Interior binding posts d. Wiring

OUTSIDE COVER

INITIAL SETUP

Tools

Light machine repair tool kit (appendix B, section III, item 11)

Pliers

Flat-tip screwdriver

Materials/Parts

Outside cover, 13222E1156

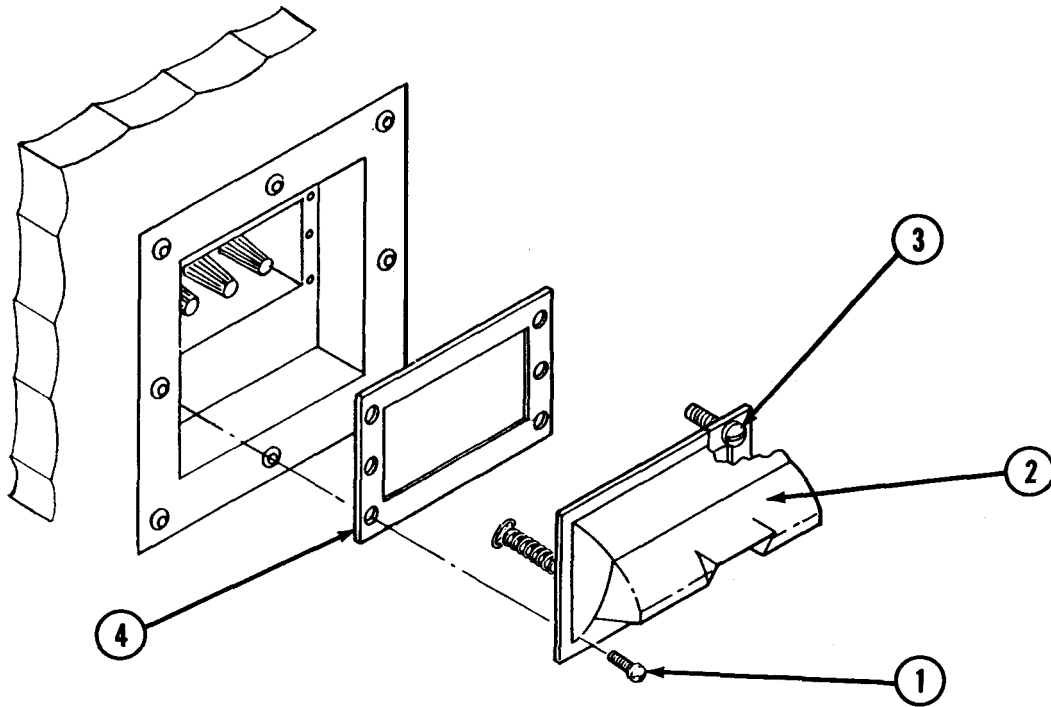

1. Tag and disconnect wires from binding posts.
2. Remove two lower screws (1) under telephone entrance panel cover (2).

2-47. REPAIR TELEPHONE INSTALLATION (CONT)

3. Close cover (2), then slide cover down.
4. Remove two top screws (3) under cover (2). Remove cover (2) and seal (4).
5. Install new seal (4) and new cover (2) with two top screws (3).
6. Open cover (2) and install two bottom screws (1).
7. Connect wires to binding posts.
8. Test operate telephone.

EXTERIOR BINDING POSTS

INITIAL SETUP

Tools

Light machine repair tool kit (appendix B, section III. item 11)
Flat-tip screwdriver
Combination wrench

Materials/Parts

Binding Posts, 5940-00-272-1477
Lead pencil (appendix C, item 13)
Masking tape (appendix C, item 29)

2-47. REPAIR TELEPHONE INSTALLATION (CONT)

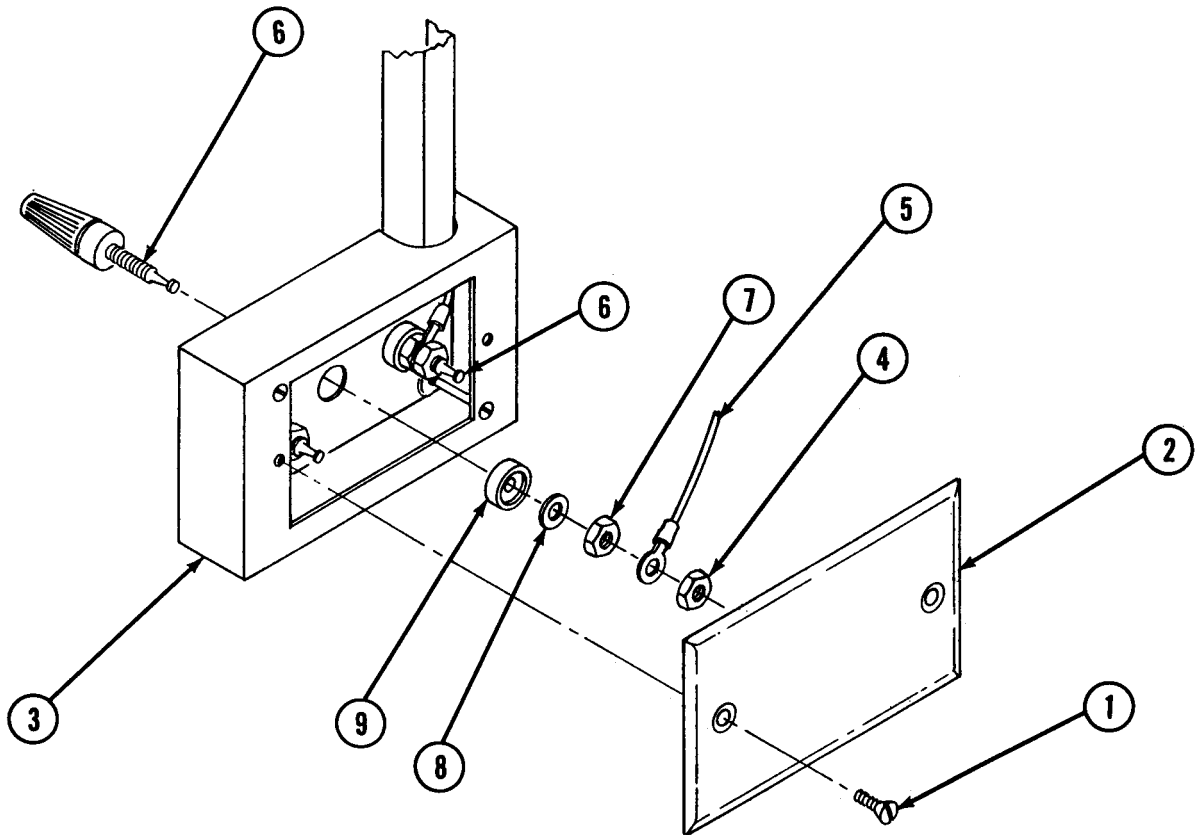

1. Remove screws (1) and cover (2) from lower telephone entrance panel receptacle box (3).
2. Remove hex nut (4). Tag and disconnect wire (5) from binding post (6).

NOTE

An extra person is required outside Section to hold binding posts in the following steps.

3. Remove hex nut (7), washer (8), and insulator ring (9).
4. Remove binding posts (6).
5. Install new binding post (6).

2-47. REPAIR TELEPHONE INSTALLATION (CONT)

6. Install insulator ring (9), washer (8), and hex nut (7).
7. Install wire (5) with hex nut (4).
8. Install telephone entrance panel receptacle box cover (2) with screws (1).
9. Test operate telephone.

INTERIOR BINDING POSTS

INITIAL SETUP

Tools

- Light machine repair tool kit (appendix B, section III, item 11)
- Flat-tip screwdriver
- Combination wrench

Materials/Parts

Binding posts, 5940-00-272-1477

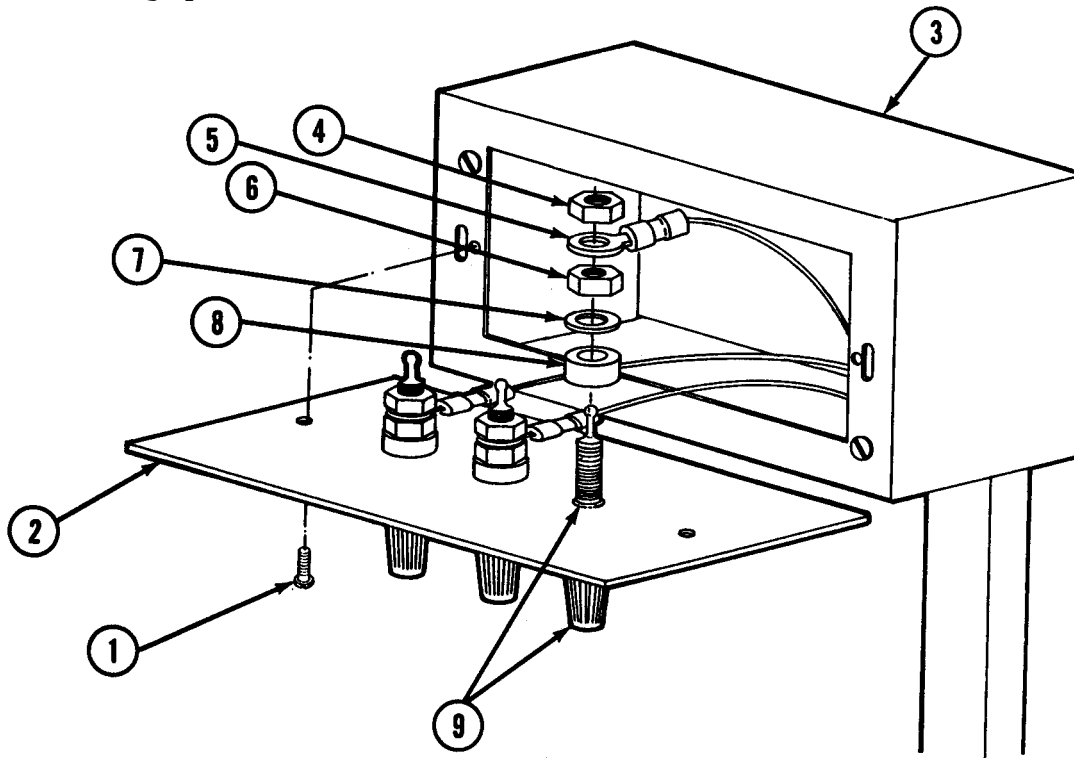

1. Remove screws (1) and cover (2) from upper telephone entrance panel receptacle box (3).

2-47. REPAIR TELEPHONE INSTALLATION (CONT)

2. Remove hex nut (4). Tag and disconnect wire (5).
3. Remove hex nut (6), washer (7), insulator ring (8), and binding post (9).
4. Install new binding post (9), insulator ring (8), washer (7), and hex nut (6).
5. Install wire (5) with hex nut (4).
6. Install cover (2) with screws (1).
7. Test operate telephone.

WIRING

INITIAL SETUP

Tools

- Light machine repair tool kit (appendix B, section III, item 11)
- Flat-tip screwdriver
- Combination wrench
- Crimping tool (appendix B, section III, item 14)

Materials/Parts

- 22 gage wire, 3 feet
- Wire eyelets (2 required)

2-47. REPAIR TELEPHONE INSTALLATION (CONT)

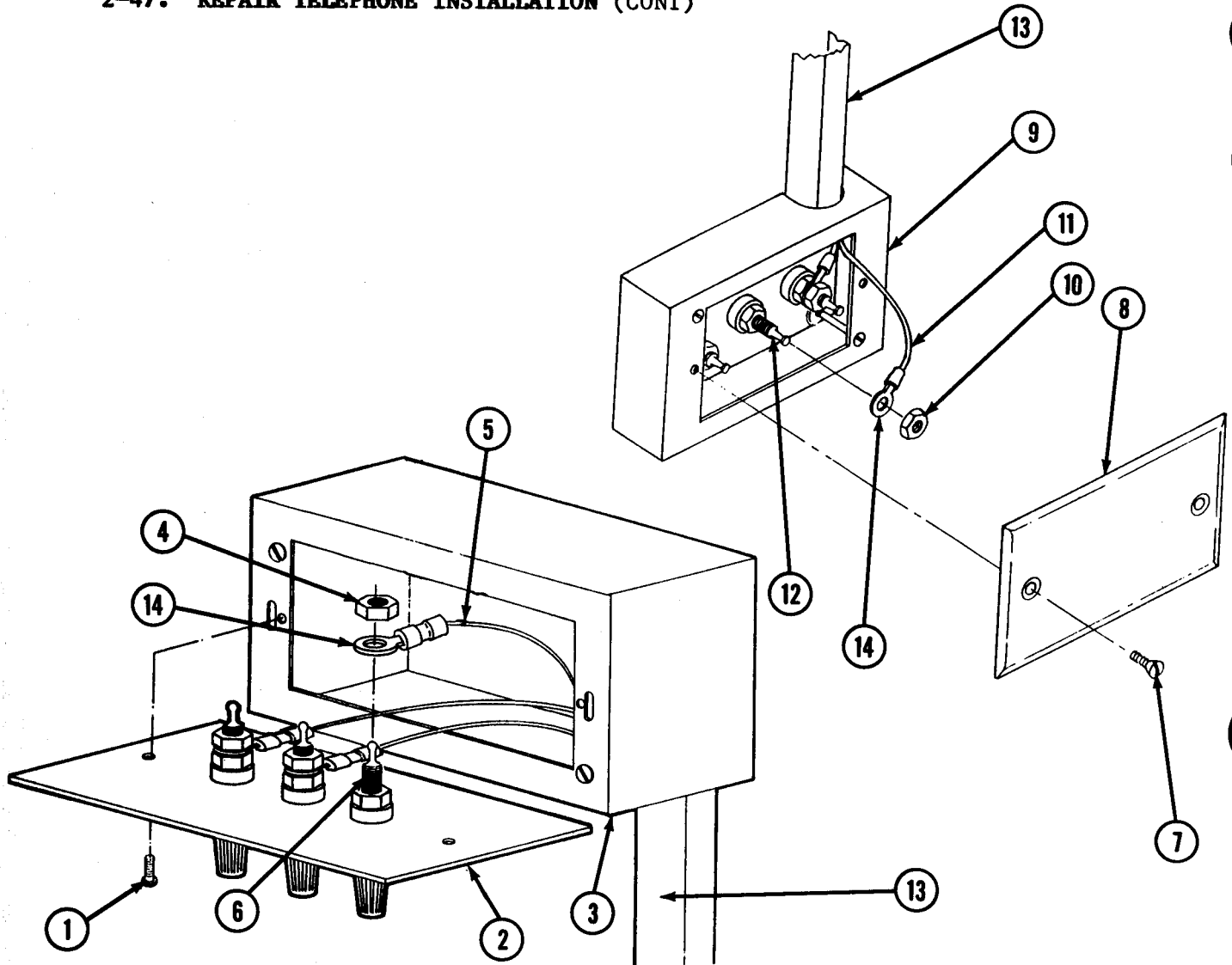

1. Remove screws (1) and cover (2) from upper telephone entrance panel receptacle box (3).
2. Remove hex nut (4) and wire (5) from binding posts (6).
3. Remove screws (7) and cover (8) from lower telephone receptacle box (9).
4. Remove hex nut (10) and wire (11) from binding posts (12).
5. Attach new wire (5) to old wire (5) and pull old wire out through conduit (13).

2-47. REPAIR TELEPHONE INSTALLATION (CONT)

6. Strip wire ends and crimp wire eyelets (14) onto ends of wire.
7. Install wire to matching binding posts on upper and lower receptacle boxes and secure with hex nuts (4) and (10).
8. Install upper telephone receptacle box cover (2) with screws (1).
9. Install lower telephone receptacle box cover (8) with screws (7).
10. Test operate telephone.

2-48. REPAIR POWER ENJOY PANEL ASSEMBLY

Power entry panel assembly is repaired by replacing: a. Power input receptacle b. DC power receptacle c. Duplex receptacle d. Grounding lug

POWER INPUT RECEPTACLE

INITIAL SETUP

Tools

- Light machine repair tool kit (appendix B, section III, item 11)
- Cross-tip screwdriver
- Flat-tip screwdriver
- Combination wrench set
- Socket wrench set
- Extension light

Materials/Parts

- Power input receptacle, X8728-16
- Lead pencil (appendix C, item 13)
- Masking tape (appendix C, item 29)
- Paint (appendix C, items 18, 19, 20)
- Aliphatic thinner (appendix C, item 32)
- Spray kit (appendix C, item 26)

2-48. REPAIR POWER ENTRY PANEL ASSEMBLY (CONT)

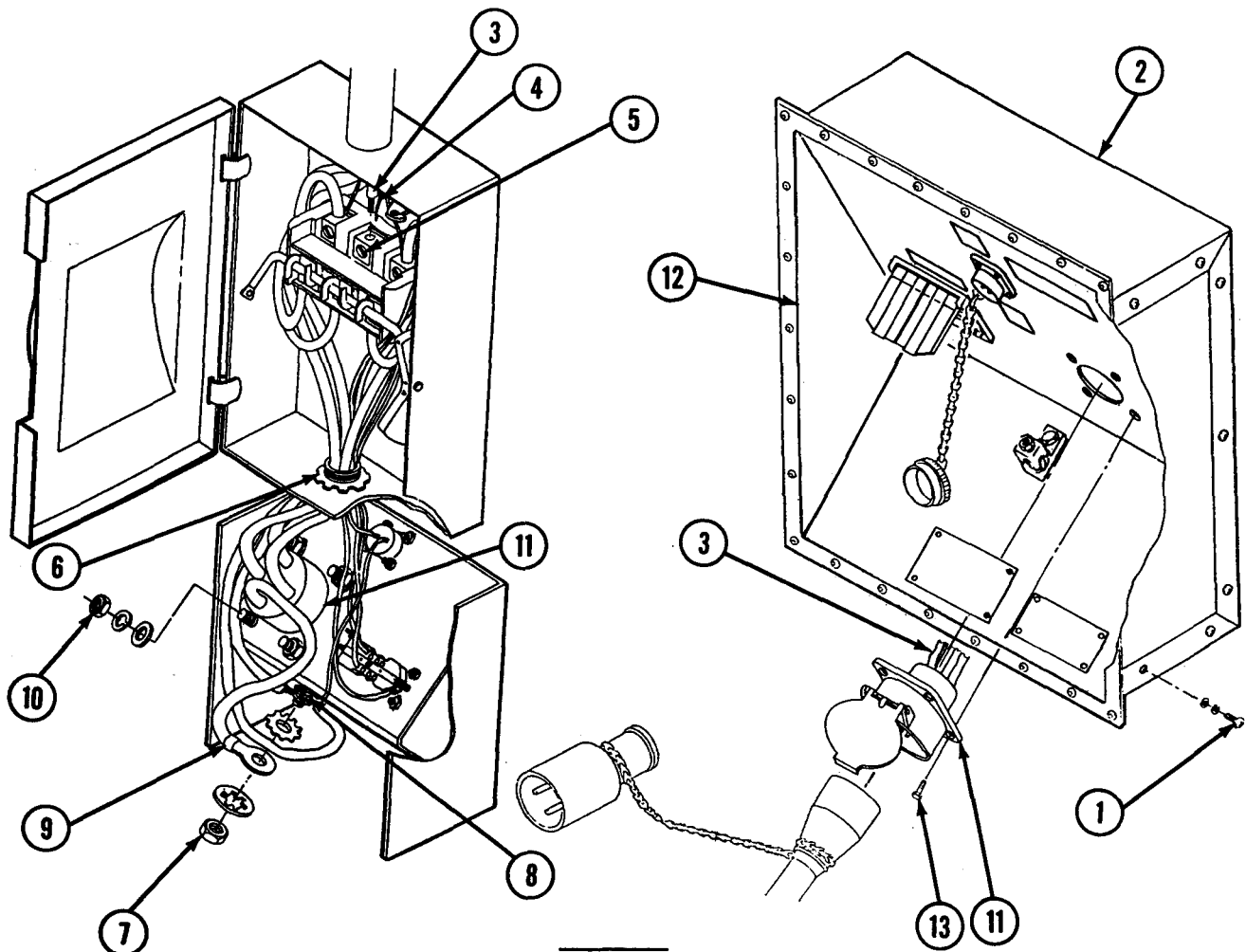

WARNING

ELECTRICAL HAZARD. Turn off main power switch and disconnect Section from power source before repairing power entry panel assembly. Failure to do so may result in death or serious injury.

1. Set MAIN POWER switch to OFF and disconnect main power cable.
2. Remove screws (1), lockwashers, flatwashers, and power entry panel cover (2).
3. Open main power switch door.

2-48. REPAIR POWER ENTRY PANEL ASSEMBLY (CONT)**WARNING**

Cables and wires on new main power receptacle MUST be tagged and installed in exactly the same order as on old receptacle. Failure to observe this warning may result in death or serious injury.

4. Tag power input cables (3) and power monitor assembly wires (4).
5. Loosen terminal block screws (5) and remove cables (3) and wires (4).
6. Pull loose power input cables (3) down through conduit (6).
7. Remove hex nut (7) and starwasher from grounding terminal (8). Remove ground cable (9).

NOTE

An extra person outside Section is required for the following procedure.

8. Inside Section, remove hex nuts (10), lockwashers, and flatwashers from power input receptacle (11).
9. Outside Section, pull power input receptacle (11) and power input cables (3) from power entry panel (12). Remove hex bolts (13).

WARNING

Cables and wires on new main power receptacle MUST be tagged and installed in exactly the same order as on old receptacle. Failure to observe this warning may result in death or serious injury.

10. Outside Section, feed cables (3) through power entry panel (12). Position new main power receptacle (11) so that dust flap opens from bottom and lifts up.
11. Outside Section, install hex bolts (13) in power input receptacle (11).
12. Inside Section, install flatwashers, lockwashers, and nuts (10) on hex bolts (13).
13. Install ground cables (9), starwasher, and hex nut (7) on grounding terminal (8).
14. Insert power input cables (3) through conduit (6).

2-48. REPAIR POWER ENTRY PANEL ASSEMBLY (CONT)

15. Install power input cables (3) and wires (4) on main power switch terminal block. Secure terminal block screws (5).
16. Close main power switch door.
17. Install power entry panel cover (2) with screws (1), lockwashers, and flatwashers.

WARNING

ELECTRICAL HAZARD. Do not connect power cable to Section before grounding. Failure to observe this warning may result in death or serious injury.

18. Ensure Section is grounded, then connect main power cable.
19. Test phase and voltage at power monitor assembly (TM 5-3610-287-10, para 2-6).
20. To test operate, set MAIN POWER switch and MAIN and auxiliary circuit breakers to ON and ensure lighting and outlets are operational.
21. If necessary, paint main power receptacle in accordance with TM 43-0139.

DC POWER RECEPTACLE

INITIAL SETUP

Tools

Light machine repair tool kit (appendix B, section III, item 11)
Cross-tip screwdriver
Flat-tip screwdriver
Combination wrench set
Extension light
Solder gun
Solder

Materials/Parts

Dc power receptacle, MS3102A-16-10P
Lead pencil (appendix C, item 13)
Masking tape (appendix C, item 29)
Paint (appendix C, items 18, 19, 20)
Aliphatic thinner (appendix C, item 32)
Spray kit (appendix C, item 29)

2-48. REPAIR POWER ENTRY PANEL ASSEMBLY (CONT)

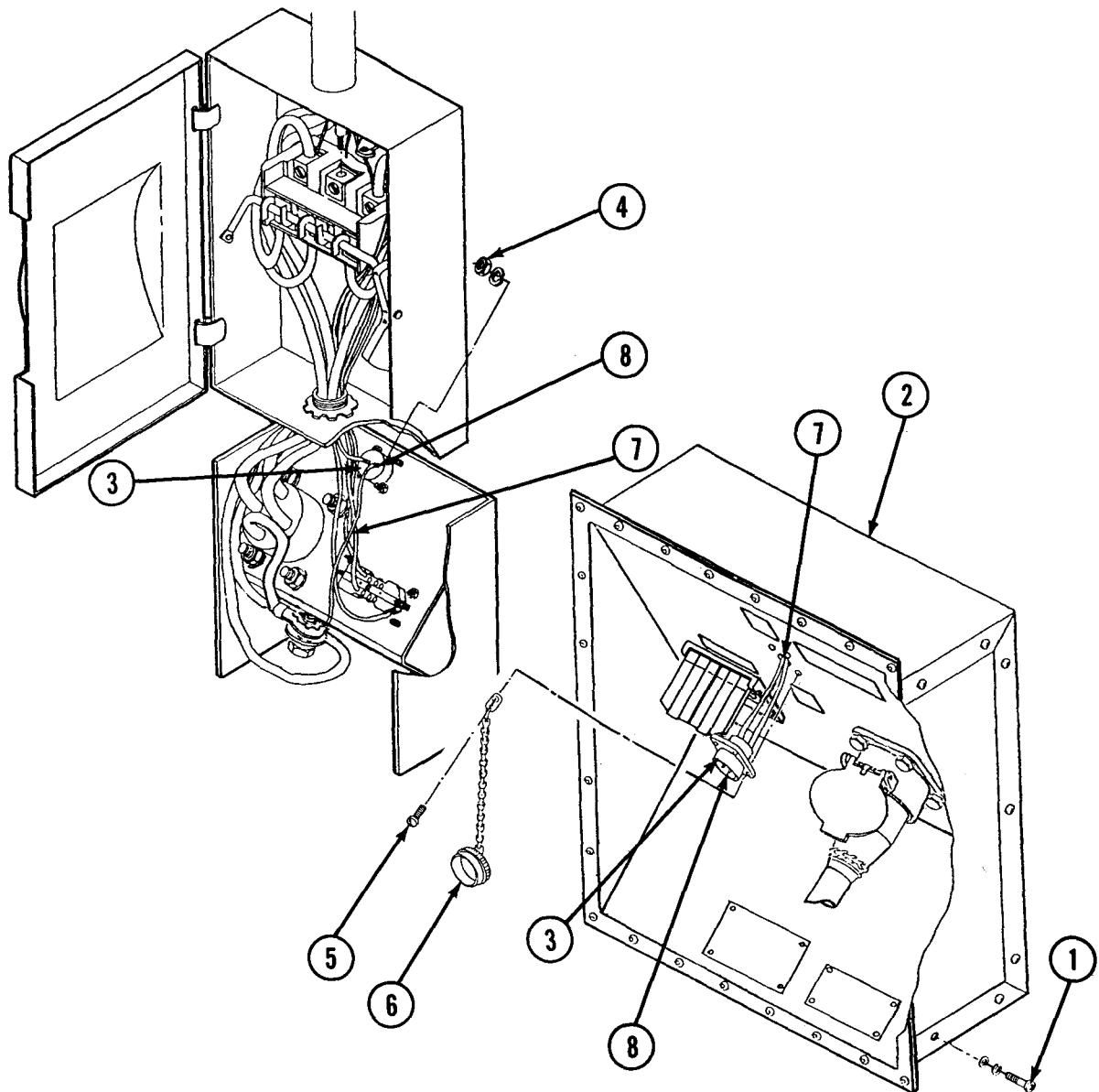
**WARNING**

ELECTRICAL HAZARD. Turn off main power switch and disconnect Section from power source before replacing dc power receptacle. Failure to do so may result in death or serious injury.

1. Set MAIN POWER switch to OFF, and disconnect main power cable.
2. Remove screws (1), lockwashers, flatwashers, and power entry panel cover (2).

2-48. REPAIR POWER ENTRY PANEL ASSEMBLY (CONT)

NOTE

An extra person outside Section is required for the following procedure.

3. Inside Section at dc power receptacle (3), remove hex nuts (4) and lockwashers.
4. Outside Section, pull back dc power receptacle (3). Remove screws (5) and dust cover (6) from dc power receptacle (3).
5. Tag and desolder wires (7) according to pins (8) inside dc power receptacle (3).
6. Solder wires (7) to pins (8) inside new dc power receptacle (3).
7. Install new dc power receptacle (3) and dust cover (6) with screws (5).
8. Inside Section at new dc power receptacle (3), install lockwashers and hex nuts (4).
9. Install power entry panel cover (2) with screws (1), lockwashers, and flatwashers.
10. To test operate, connect external 12-volt dc power source and ensure dome lights are operational.
11. If necessary, paint dc power receptacle in accordance with TM 43-0139.

DUPLEX RECEPTACLE

INITIAL SETUP

Tools

Light machine repair tool kit (appendix B, section III, item 11)
Cross-tip screwdriver
Flat-tip screwdriver
Extension light
Combination wrench set
Scraping knife (appendix B, section III, item 9)

2-48. REPAIR POWER ENTRY PANEL ASSEMBLY (CONT)

Materials/Parts

- Duplex receptacle, 5739
- Silicone compound (appendix C, item 7)
- Spray kit (appendix C, item 26)
- Paint (appendix C, items 18, 19, 20)
- Aliphatic thinner (appendix C, item 32)
- Masking tape (appendix C, item 29)
- Lead pencil (appendix C, item 13)

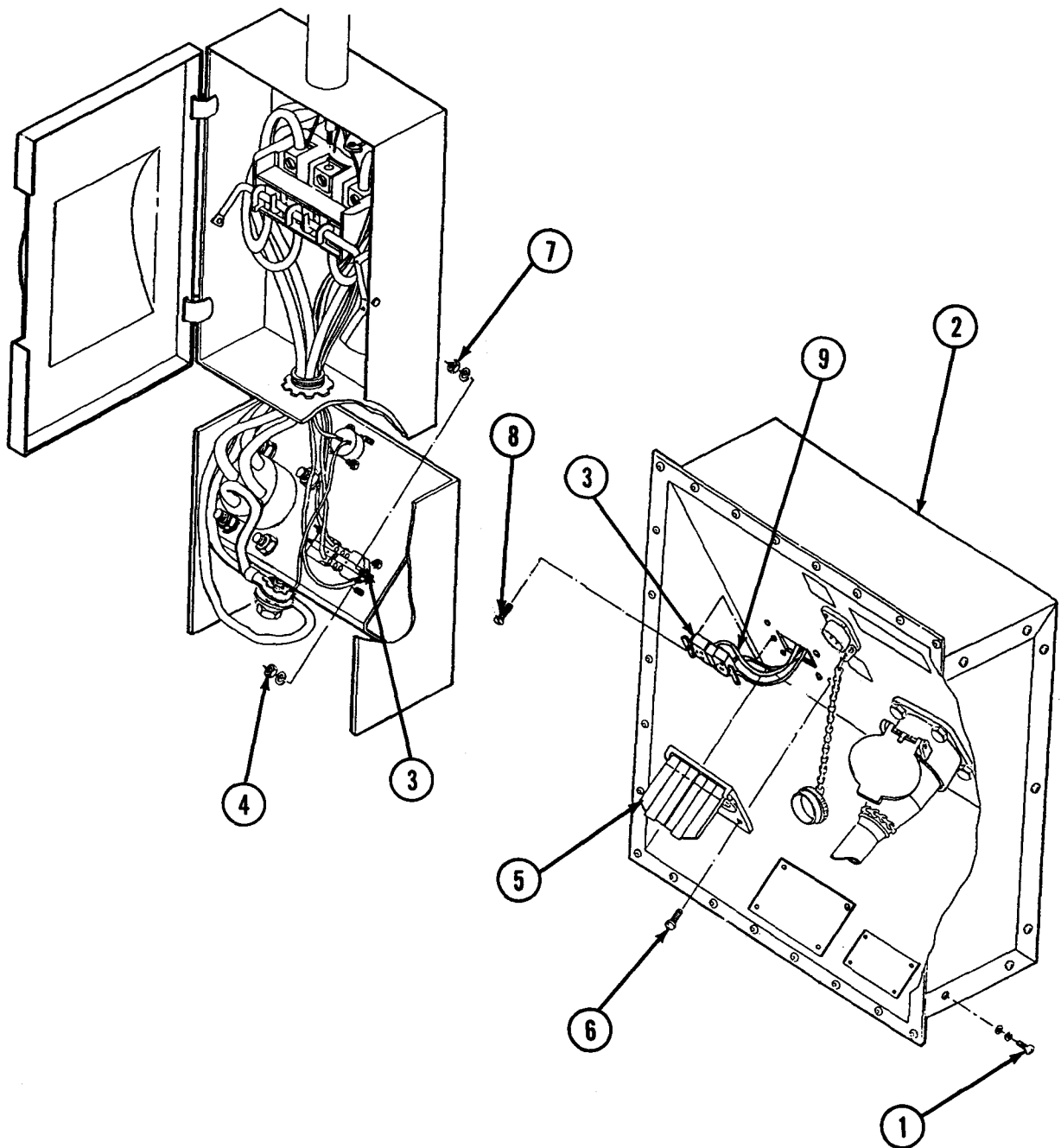

2-48. REPAIR POWER ENTRY PANEL ASSEMBLY (CONT)

WARNING

ELECTRICAL HAZARD. Turn off main power switch and disconnect Section from power source before replacing duplex receptacle. Failure to do so may result in death or serious injury.

1. Set MAIN POWER switch to OFF and disconnect main power cable.
2. Remove screws (1), lockwashers, flatwashers, and power entry panel cover (2).

NOTE

An extra person outside Section is required for the following procedure.

3. Inside Section at duplex receptacle (3), remove hex nuts (4) and lockwashers.
4. Outside Section, remove waterproof cover (5) and screws (6).
5. Inside Section, remove hex nut (7) and lockwashers.
6. Outside Section, remove screws (8) from duplex receptacle (3). Pull duplex receptacle (3) out.
7. Outside Section at duplex receptacle (3), tag and disconnect wires (9).
8. Scrape silicone compound from power entry panel and waterproof cover (5).
9. Connect wires (9) to new duplex receptacle (3).
10. Install duplex receptacle (3) with screws (8).
11. Inside Section, install lockwashers and hex nuts (7).

WARNING

CHEMICAL HAZARD. Use silicone compound in a well-ventilated area. Silicone compound is harmful to eyes and skin. In case of contact with eyes, immediately flush eyes with water for 15 minutes, then seek medical help. In case of contact with skin, wipe off with dry cloth, then wash with soap and water.

12. Outside Section, apply silicone compound to back of waterproof cover (5) and install with screws (6).

2-48. REPAIR POWER ENTRY PANEL ASSEMBLY (CONT)

13. Inside Section, install lockwashers and hex nuts (4).
14. Install power entry panel cover (2) with screws (1), lockwashers, and flatwashers.

WARNING

ELECTRICAL HAZARD. Do not connect power cable to Section before grounding. Failure to observe this warning may result in death or serious injury.

15. Ensure Section is grounded, then connect main power cable.
16. To test operate, set MAIN POWER switch and MAIN and ROADSIDE OUTLET circuit breakers to ON. Ensure roadside outlets are operational.
17. If necessary, paint duplex receptacle in accordance with TM 43-0139.

GROUNDING LUG**INITIAL SETUP****Tools**

Light machine repair tool kit (appendix B, section III, item 11)
 Cross-tip screwdriver
 Combination wrench set
 Extension light

Materials/Parts

Grounding lug, QA26B
 Spray kit (appendix C, item 26)
 Paint (appendix C, items 18, 19, 20)
 Aliphatic thinner (appendix C, item 32)

2-48. REPAIR POWER ENTRY PANEL ASSEMBLY (CONT)

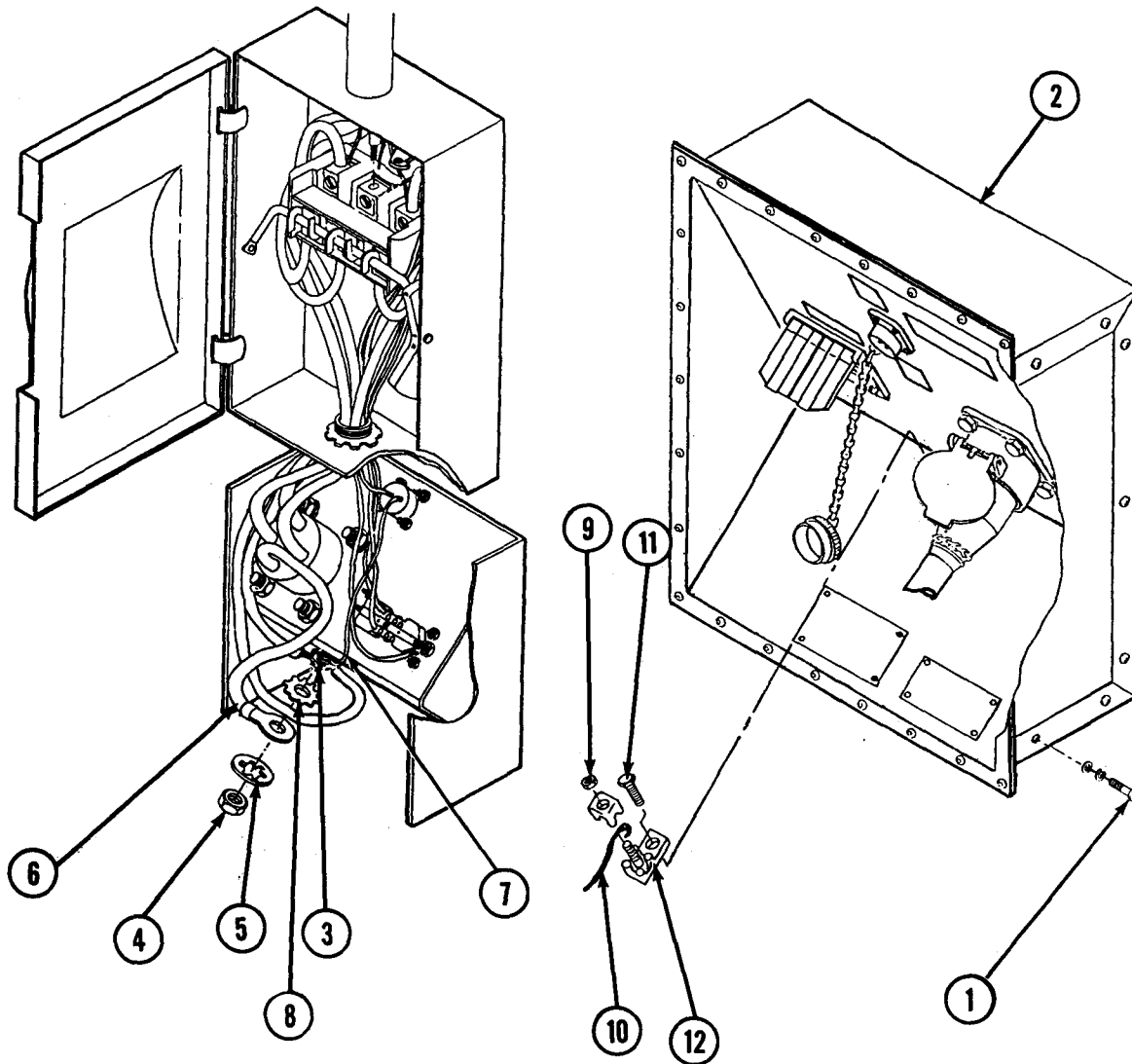

WARNING

ELECTRICAL HAZARD. Turn off main power switch and disconnect Section from power source before replacing grounding lug. Failure to do so may result in death or serious injury.

1. Set MAIN POWER switch to OFF and disconnect main power cable.
2. Remove screws (1), lockwashers, flatwashers, and power entry panel cover (2).
3. Inside Section at grounding lug post (3), remove hex nut (4), starwasher (5), three grounding cables (6), one grounding wire (7), and starwasher (8).

2-48. REPAIR POWER ENTRY PANEL ASSEMBLY (CONT)

4. Outside Section, loosen hex nut (9) and remove grounding cable (10).
5. Remove hex bolt (11) and grounding lug (12).
6. Install new grounding lug (12) with hex bolt (11).
7. Install old grounding cable (10) and tighten hex nut (9).
8. Inside Section at grounding lug post (3), install starwasher (8), grounding wire (7), three grounding cables (6), starwasher (5), and hex nut (4).
9. Install power entry panel cover (2) with screws (1), lockwashers, and flatwashers.
10. If necessary, paint grounding lug in accordance with TM 43-0139.

2-49. REPLACE POWER MONITOR ASSEMBLY

This task covers: a. Removal b. Installation

INITIAL SETUP**Tools**

Light machine repair tool kit (appendix B, section III, item 11)
Socket wrench set
Soldering iron
Solder
Extension light

Materials/Parts

Power monitor assembly, 13225E4381
Wire ties, 230425N (2 required)

2-49. REPLACE POWER MONITOR ASSEMBLY (CONT)

REMOVAL

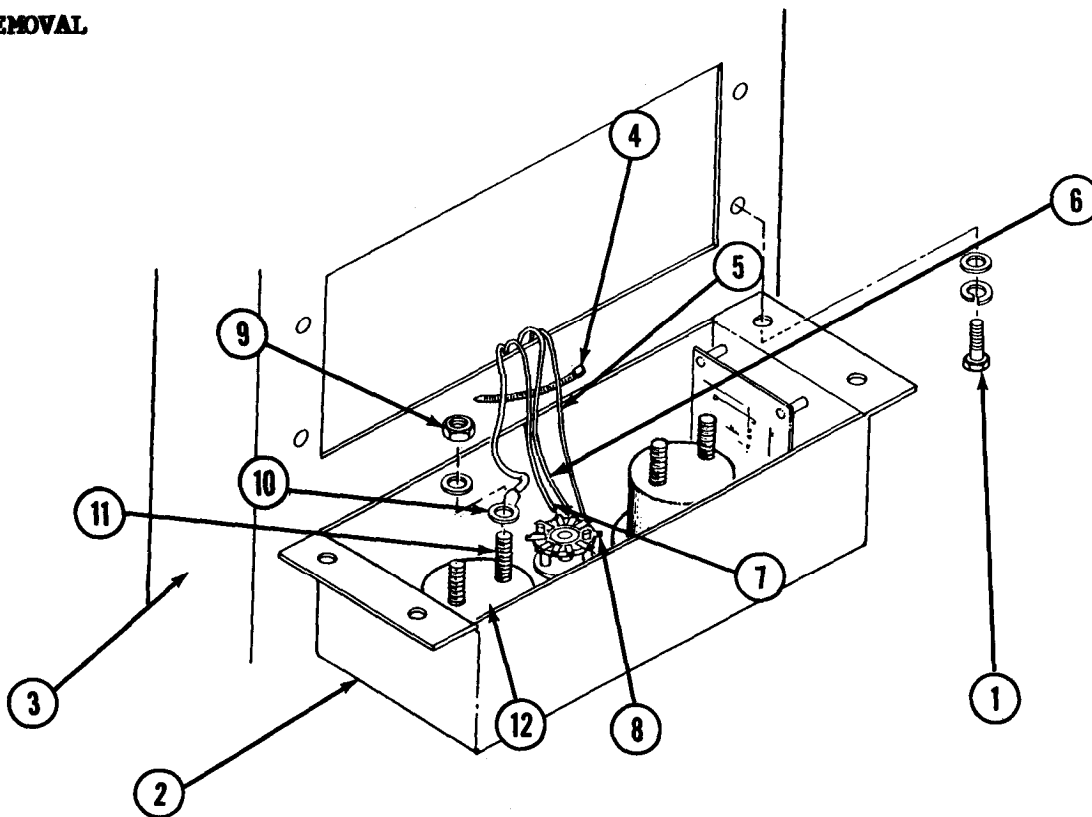

WARNING

ELECTRICAL HAZARD. Main power cable MUST be disconnected from Section before performing maintenance on power monitor assembly. Wiring to power monitor assembly comes directly from main power input receptacle. Failure to disconnect main power cable WILL result in death or serious injury.

1. Set MAIN POWER switch to OFF and disconnect power cable.
2. Remove hex bolts (1), lockwashers, and flatwashers. Rest power monitor assembly (2) on load center (3).
3. Remove wire ties (4).
4. Desolder black (5), blue (6), and red (7) leads from rotary switch (8).
5. Remove hex nut (9), flatwasher, and white lead (10) from terminal (11) of voltage meter (12).
6. Remove power monitor assembly (2).

2-49. REPLACE POWER MONITOR ASSEMBLY (CONT)**INSTALLATION****WARNING**

ELECTRICAL HAZARD. Main power cable MUST be disconnected from Section before performing maintenance on power monitor assembly. Wiring to power monitor assembly comes directly from main power input receptacle. Failure to disconnect main power cable WILL result in death or serious injury.

1. Position new power monitor assembly (2) and secure white lead (10), flatwasher, and hex nut (9) on terminal (11) of voltage meter (12).
2. Solder black (5), blue (6), and red (7) leads to rotary switch (8).
3. Install wire ties (4).
4. Install power monitor assembly (2) with hex bolts (1), lockwashers, and flatwashers.

WARNING

ELECTRICAL HAZARD. Do not connect power cable to Section before grounding. Failure to observe this warning may result in death or serious injury.

5. Ground Section and connect power cable.
6. Test operate by checking for correct phase and voltage (TM 5-3610-287-10, para 2-6).
7. Set MAIN POWER switch to ON.

2-50. REPAIR POWER MONITOR ASSEMBLY

Power monitor assembly is repaired by replacing: a. Voltage meter
b. Frequency meter c. Circuit card assembly

VOLTAGE METER**INITIAL SETUP****Tools**

Light machine repair tool kit (appendix B, section III, item 11)
Combination wrench set
Socket wrench set
Extension light

2-50. REPAIR POWER MONITOR ASSEMBLY (CONT)

Materials/Parts

- Voltage meter, 331S, 0-150V
- Masking tape (appendix C, item 29)
- Lead pencil (appendix C, item 13)

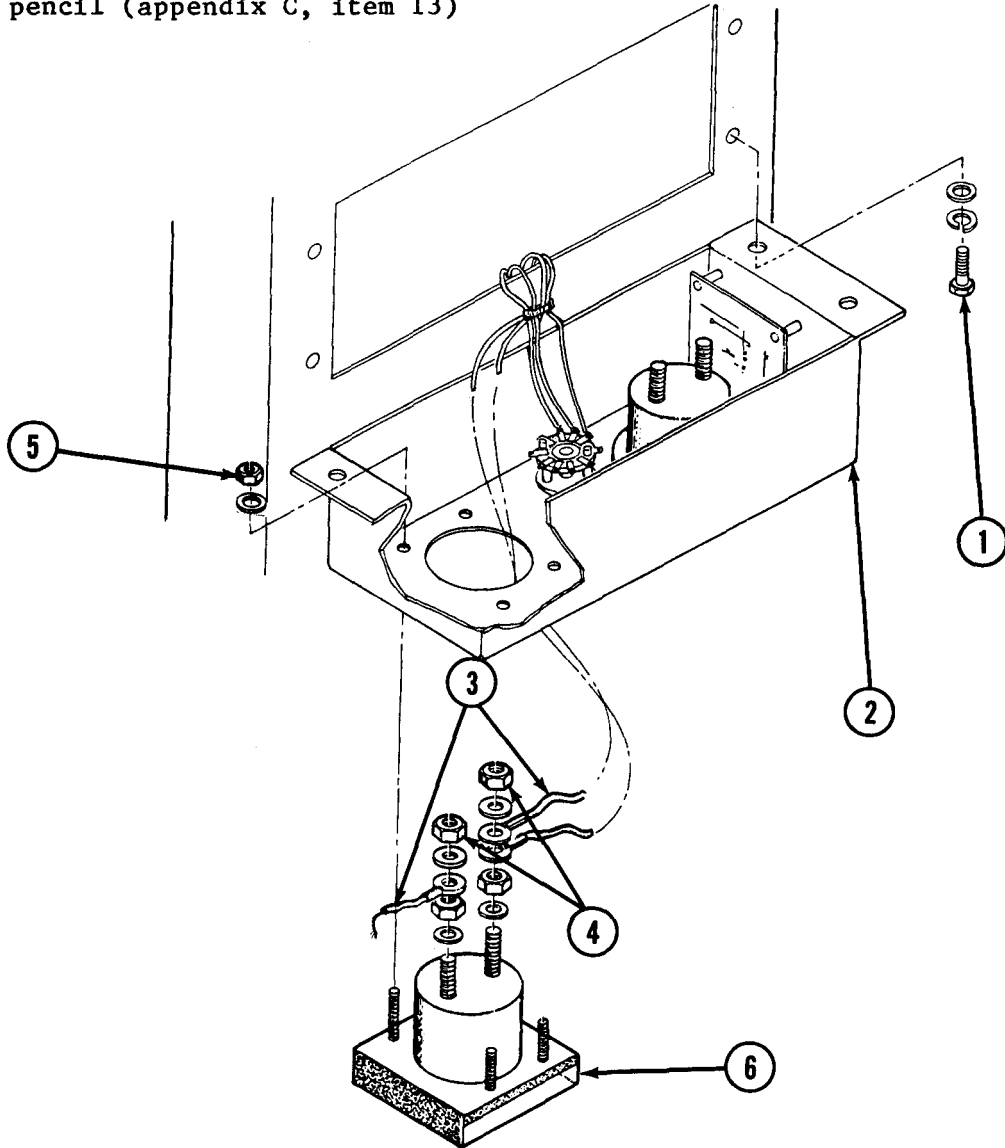

WARNING

ELECTRICAL HAZARD. Main power cable MUST be disconnected from Section before performing maintenance on power monitor assembly. Wiring to power monitor assembly comes directly from main power input receptacle. Failure to disconnect main power cable WILL result in death or serious injury.

1. Set MAIN POWER switch to OFF and disconnect main power cable.

2-50. REPAIR POWER MONITOR ASSEMBLY (CONT)

2. Remove hex bolts (1), lockwashers, and flatwashers. Rest power monitor assembly (2) on load center.
3. Tag wires (3) and remove hex nuts (4), flatwashers, and wires (3).
4. Remove hex nuts (5), flatwashers, and voltage meter (6).
5. Install new voltage meter (6) with hex nuts (5) and flatwashers.
6. Install wires (3) with hex nuts (4) and flatwashers.
7. Install power monitor assembly (2) with hex bolts (1), lockwashers, and flatwashers.

WARNING

ELECTRICAL HAZARD. Do not connect power cable to Section before grounding. Failure to observe this warning may result in death or serious injury.

8. Ground Section and connect main power cable.
9. Test operate by checking for correct phase and voltage (TM 5-3610-287-10, para 2-6).
10. Set MAIN POWER switch to ON.

FREQUENCY METER**INITIAL SETUP****Tools**

Light machine repair tool kit (appendix B, section III, item 11)
 Flat-tip screwdriver
 Socket wrench set
 Combination wrench set
 Extension light

Materials/Parts

Frequency meter, 31FX, 60 CPS
 Masking tape (appendix C, item 29)
 Lead pencil (appendix C, item 13)

2-50. REPAIR POWER MONITOR ASSEMBLY (CONT)

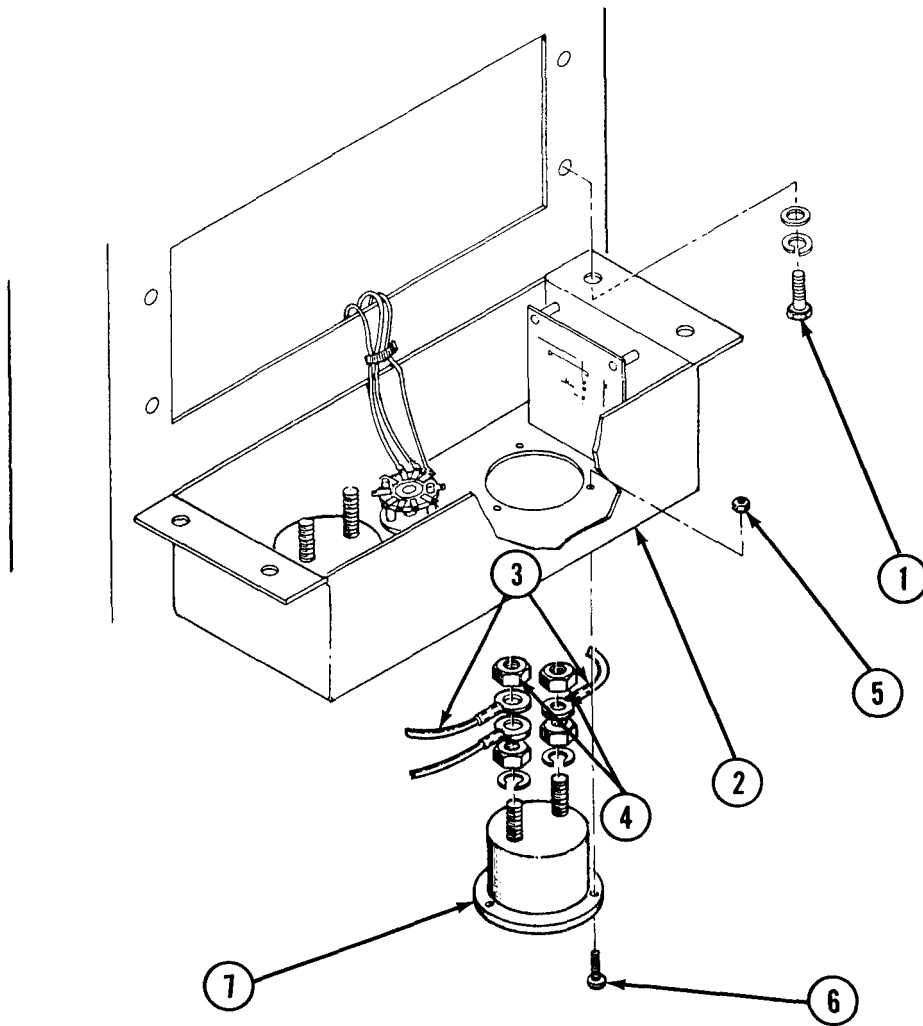

WARNING

ELECTRICAL HAZARD. Main power cable **MUST** be disconnected from Section before performing maintenance on power monitor assembly. Wiring to power monitor assembly comes directly from main power input receptacle. Failure to disconnect main power cable **WILL** result in death or serious injury.

1. Set MAIN POWER switch to OFF and disconnect main power cable.
2. Remove hex bolts (1), lockwashers, and flatwashers. Rest power monitor assembly (2) on load center.
3. Tag wires (3). Remove hex nuts (4), flatwashers, and wires (3).

2-50. REPAIR POWER MONITOR ASSEMBLY (CONT)

4. Remove nuts (5), screws (6), and frequency meter (7).
5. Install new frequency meter (7) with screws (6) and nuts (5).
6. Install wires (3), flatwashers, and hex nuts (4).
7. Install power monitor assembly (2) with hex bolts (1), lockwashers, and flatwashers.

WARNING

ELECTRICAL HAZARD. Do not connect power cable to Section before grounding. Failure to observe this warning may result in death or serious injury.

8. Ground Section and connect main power cable.
9. Test operate by checking for correct phase and voltage (TM 5-3610-287-10, para 2-6).
10. Set MAIN POWER switch to ON.

CIRCUIT CARD ASSEMBLY**INITIAL SETUP****Tools**

Light machine repair tool kit (appendix B, section III, item 11)
 Cross-tip screwdriver
 Flat-tip screwdriver
 Socket wrench set
 Soldering iron
 Solder
 Extension light

Materials/Parts

Circuit card assembly, 13225E3282
 Masking tape (appendix C, item 29)
 Lead pencil (appendix C, item 13)

2-50. REPAIR POWER MONITOR ASSEMBLY (CONT)

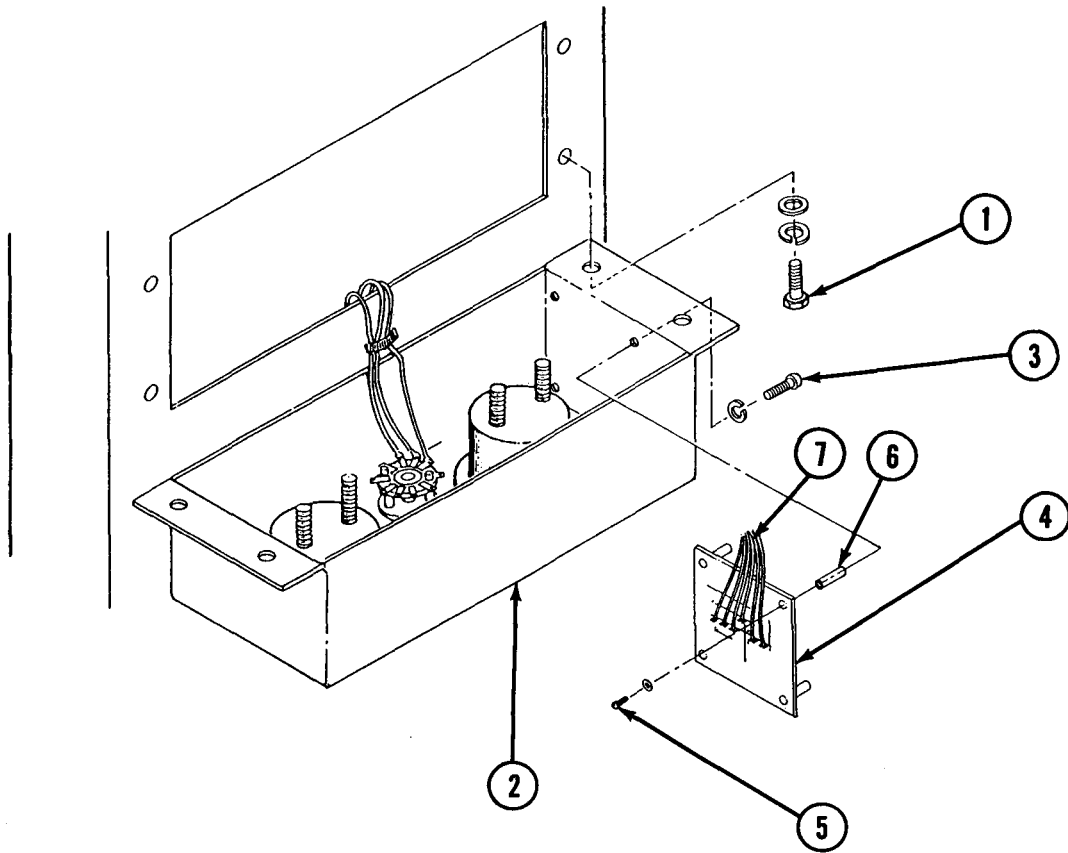

WARNING

ELECTRICAL HAZARD. Main power cable MUST be disconnected from Section before performing maintenance on power monitor assembly. Wiring to power monitor assembly comes directly from main power input receptacle. Failure to disconnect main power cable WILL result in death or serious injury.

1. Set MAIN POWER switch to OFF and disconnect main power cable.
2. Remove hex bolts (1), lockwashers, and flatwashers. Rest power monitor assembly (2) on load center.
3. Remove screws (3) and lockwashers, and partially remove circuit card assembly (4).
4. Remove screws (5), lockwashers, and standoffs (6).
5. Tag and remove wires (7) and circuit card assembly (4).

2-50. REPAIR POWER MONITOR ASSEMBLY (CONT)

6. Install standoffs (6) on new circuit card assembly (4) with screws (5) and lockwashers.
7. Install wires (7) on circuit card assembly (4).
8. Install circuit card assembly (4) with screws (3) and lockwashers.
9. Install power monitor assembly (2) with hex bolts (1), lockwashers, and flatwashers.

WARNING

ELECTRICAL HAZARD. Do not connect power cable to Section before grounding. Failure to observe this warning may result in death or serious injury.

10. Ground Section and connect main power cable.
11. Test operate by checking for correct phase and voltage (TM 5-3610-287-10, para 2-6).
12. Set MAIN POWER switch to ON.

2-51. REPAIR LOAD CENTER

Load center is repaired by replacing: a. 110-Volt circuit breaker
b. 12-Volt circuit breaker c. Main power switch

110-VOLT CIRCUIT BREAKERINITIAL SETUPTools

Light machine repair tool kit (appendix B, section III, item 11)
Flat-tip screwdriver
Extension light

Materials/Parts

GFI circuit breaker, QF-120
Main circuit breaker, Q3100
70 Amp circuit breaker, 3 pole, Q370
20 Amp circuit breaker, 3 pole, Q320
20 Amp circuit breaker, 2 pole, Q220
20 Amp dual circuit breaker, Q2020
20 Amp circuit breaker, Q120
15 Amp dual circuit breaker, Q1515
15 Amp circuit breaker, Q115
Masking tape (appendix C, item 29)
Lead pencil (appendix C, item 13)

2-51. REPAIR LOAD CENTER (CONT)

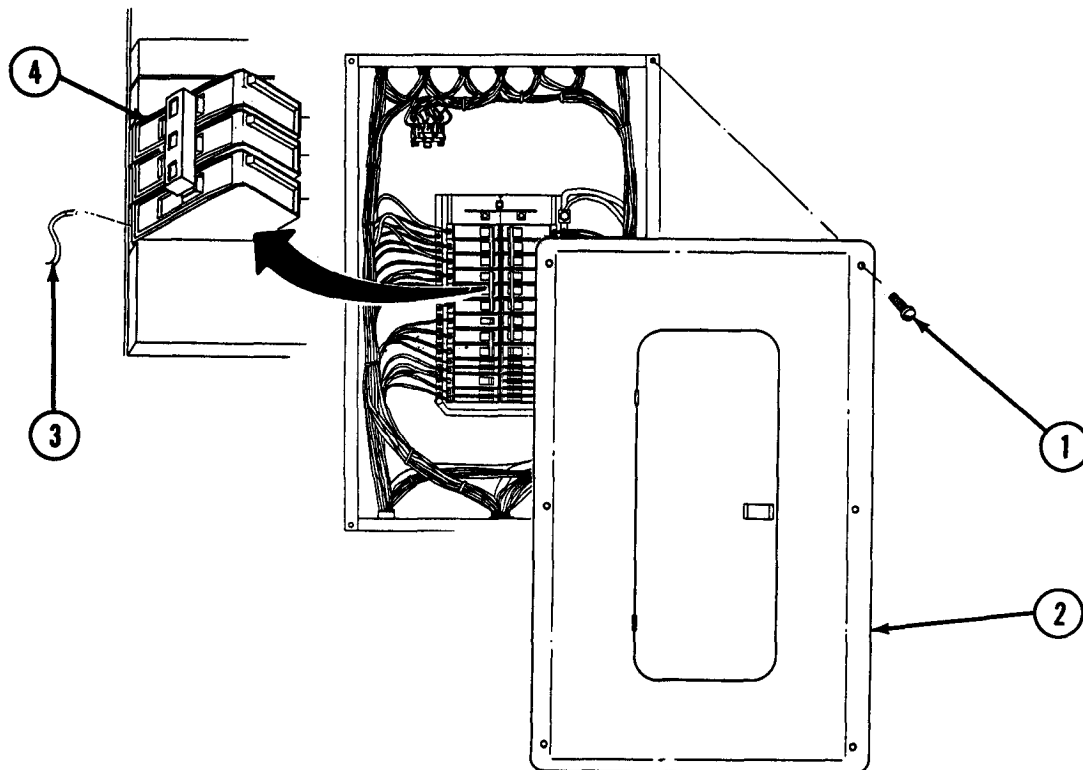

WARNING

ELECTRICAL HAZARD. Turn off main power switch before repairing load center. Failure to do so may result in death or serious injury.

1. Set MAIN POWER switch to OFF.
2. Remove screws (1) and circuit breaker panel cover (2).
3. Tag and remove wiring (3) from defective circuit breaker (4).
4. Insert screwdriver between rows of circuit breakers. Carefully pry defective circuit breaker (4) toward outside edge of circuit breaker panel and remove defective circuit breaker.
5. Insert new circuit breaker (4) in panel.
6. Install wiring (3).
7. Position circuit breaker panel cover (2) and install screws (1).
8. Set MAIN POWER switch and MAIN circuit breaker to ON.
9. To test operate, set auxiliary circuit breakers to ON and ensure that replacement circuit breaker does not trip.

2-51. REPAIR LOAD CENTER (CONT)

12-VOLT CIRCUIT BREAKER

INITIAL SETUP

Tools

- Light machine repair tool kit (appendix B, section III, item 11)
- Flat-tip screwdriver
- Cross-tip screwdriver
- Combination wrench set

Materials/Parts

- 12-Volt circuit breaker, 30055-15
- Masking tape (appendix C, item 29)
- Lead pencil (appendix C, item 13)

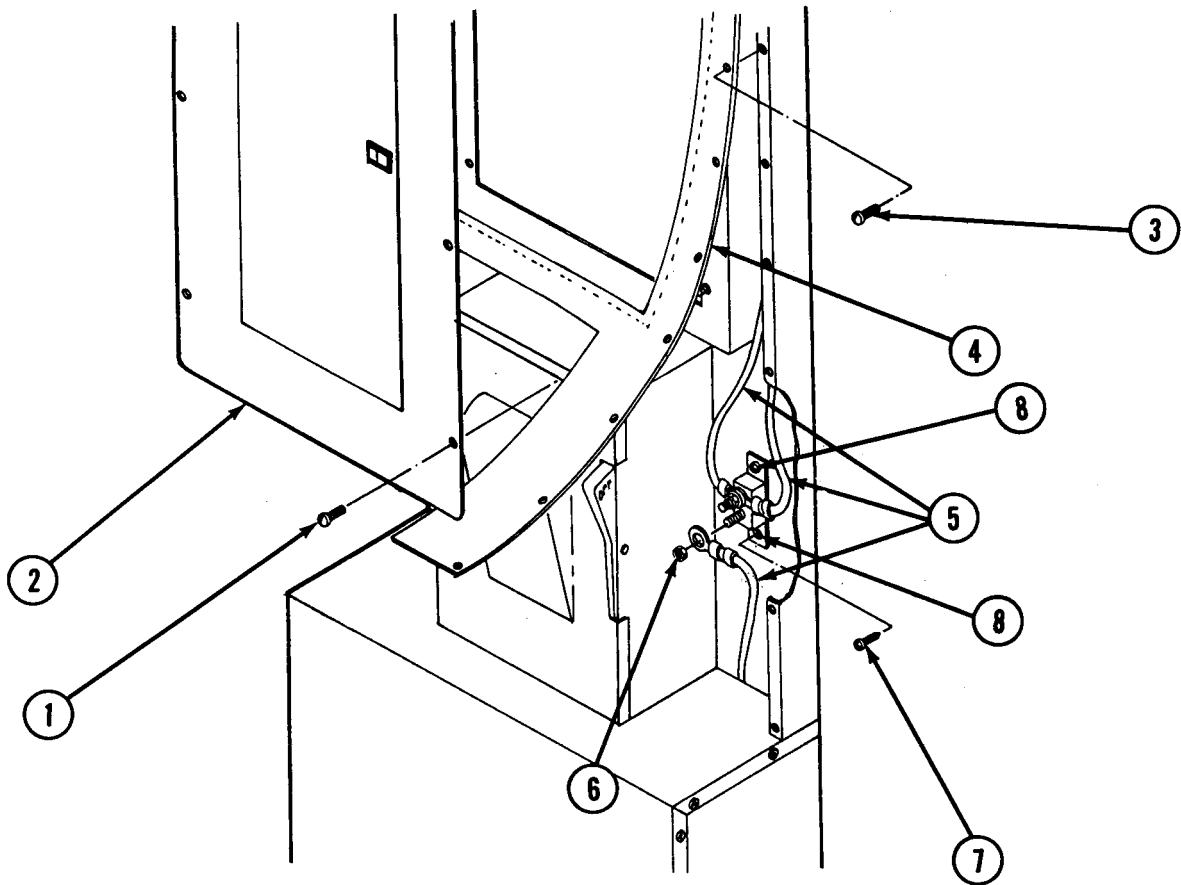

2-51. REPAIR LOAD CENTER (CONT)

WARNING

Turn off main power switch before repairing load center.
Failure to do so may result in death or serious injury.

1. Set MAIN POWER switch to OFF.
2. Remove screw (1) and circuit breaker cover panel (2).
3. Remove screws (3) along right side of load center and pull back load center cover (4).
4. Tag wires (5).
5. Remove hex nuts (6) and wires (5).
6. Remove screws (7) and 12-volt circuit breaker (8).
7. Install new 12-volt circuit breaker (8) with screws (7).
8. Install wires (5) with hex nuts (6).
9. Install load center cover (4) with screws (3).
10. Install circuit breaker cover panel (2) with screws (1).
11. Set MAIN POWER switch to ON.
12. To test operate, connect 12-volt power source to Section and ensure dome lights operate.

MAIN POWER SWITCH

INITIAL SETUP

Tools

Light machine repair tool kit (appendix B, section III, item 11)
Cross-tip screwdriver
Flat-tip screwdriver
Pipe wrench

Materials/Parts

Main switch, JU323
Masking tape (appendix C, item 29)
Lead pencil (appendix C, item 13)

2-51. REPAIR LOAD CENTER (CONT)

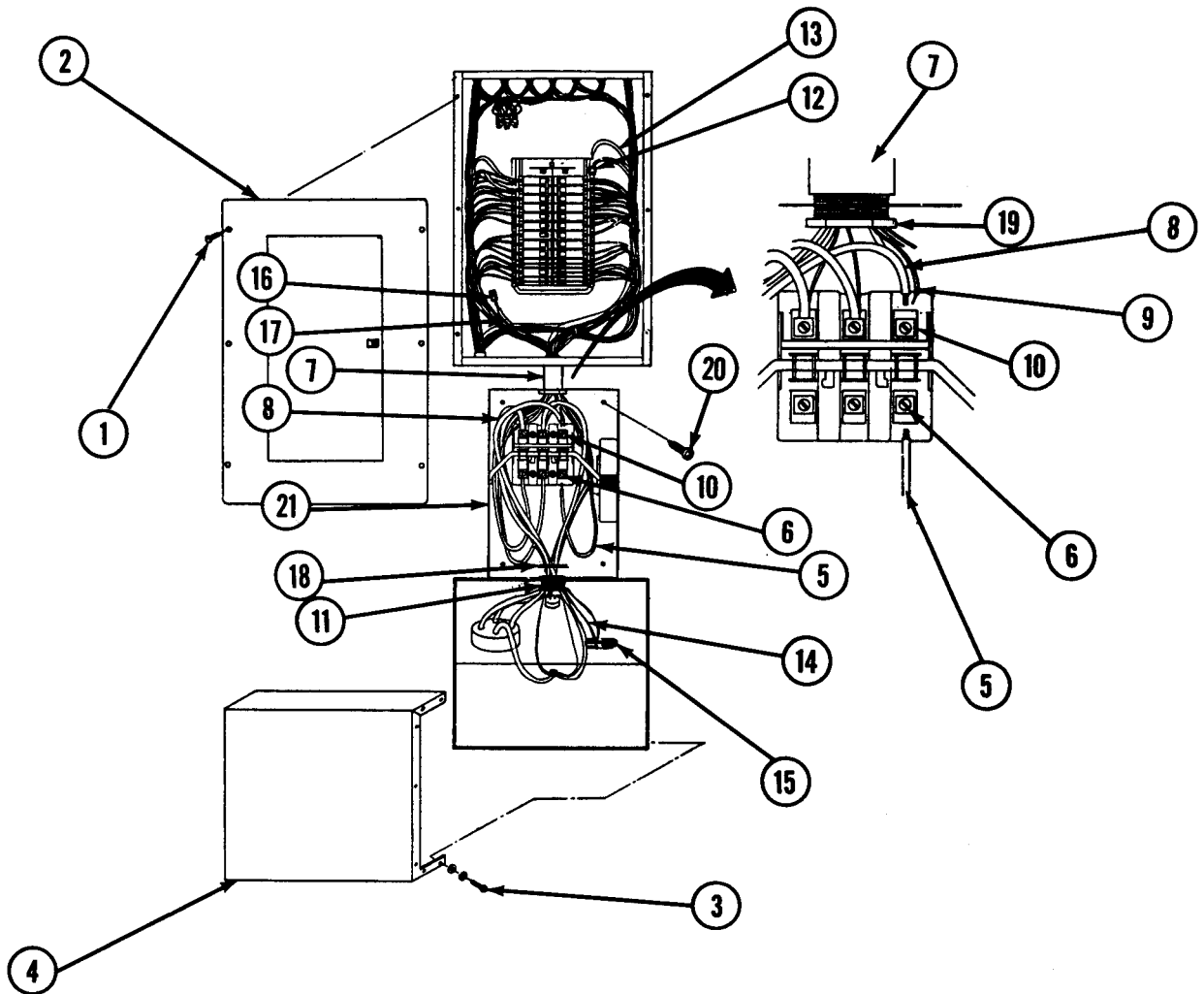

WARNING

ELECTRICAL HAZARD. Turn off main power switch and disconnect main power cable before replacing main power switch. Failure to do so may result in death or serious injury.

1. Set MAIN POWER switch to OFF and disconnect main power cable.
2. Remove screws (1) and circuit breaker cover panel (2).
3. Remove screws (3), lockwashers, flatwashers, and power entry panel cover (4).

2-51. REPAIR LOAD CENTER (CONT)

WARNING

Pay careful attention when tagging cables and wires on main power receptacle. Cables and wires on new receptacle must be installed in exactly the same order as on old receptacle. Failure to observe this warning may result in death or serious injury.

4. Tag wires (5), loosen screws (6), remove wires (5), and pull through conduit (7).
5. Tag main power receptacle cables (8) and power monitor assembly wires (9). Loosen screws (10) and remove-wires (9) and cables (8).
6. Pull cables (8) through conduit (11).
7. Loosen screw (12), remove white grounding cable (13), and pull through conduits (7) and (11).
8. Tag and remove wires (14) from exterior receptacle (15). Pull wires (14) through conduits (11) and (7).
9. Loosen screw (16), remove green ground wire (17), and pull through conduits (7) and (11).
10. Remove segmented locknut (18) and conduit (11).
11. Remove plug (19) from conduit (7).
12. Remove screws (20) and main power switch (21).
13. Install new main power switch (21) with screws (20).
14. Install plug (19) in conduit (7).
15. Install conduit (11) with segmented locknut (18).

WARNING

Cables and wires on new main power switch must be installed in exactly the same order as on old switch. Failure to observe this warning may result in death or serious injury.

16. Feed green ground wire (17) through conduits (11) and (7) and install with screw (16).
17. Feed wires (14) through conduits (7) and (11) connect to exterior receptacle (15).

2-51. REPAIR LOAD CENTER (CONT)

18. Feed white ground cable (13) through conduits (11) and (7) and install with screw (12).
19. Feed power receptacle cables (8) through conduit (11).
20. Install cables (8) and power monitor assembly wires (9) with screws (10).
21. Feed wires (5) through conduit (7) and install with screws (6).
22. Install power entry panel cover (4) with screws (3), lockwashers, and flatwashers.
23. Install circuit breaker cover panel (2) with screws (1).

WARNING

ELECTRICAL HAZARD. Do not connect power cable to Section before grounding. Failure to observe this warning may result in death or serious injury.

24. Ground Section and connect main power cable.
25. Test for correct phase and voltage (TM 5-3610-287-10, para 2-6) before setting MAIN POWER switch to ON.
26. To test operate, set MAIN POWER switch and MAIN and auxiliary circuit breakers to ON and ensure lighting and outlets are operational.

2-52. REPAIR BLACKOUT LIGHT SYSTEM

Blackout light system is repaired by replacing: a. Bulb socket
b. Marker light c. Door switch d. Relay

BULB SOCKET**INITIAL SETUP****Tools**

Light machine repair tool kit (appendix B, section III, item 11)
Flat-tip screwdriver
Cross-tip screwdriver
Pliers

Materials/Parts

Bulb socket
Wire nut, 2978 (2 required)
Masking tape (appendix C, item 29)
Lead pencil (appendix C, item 13)

2-52. REPAIR BLACKOUT LIGHT SYSTEM (CONT)

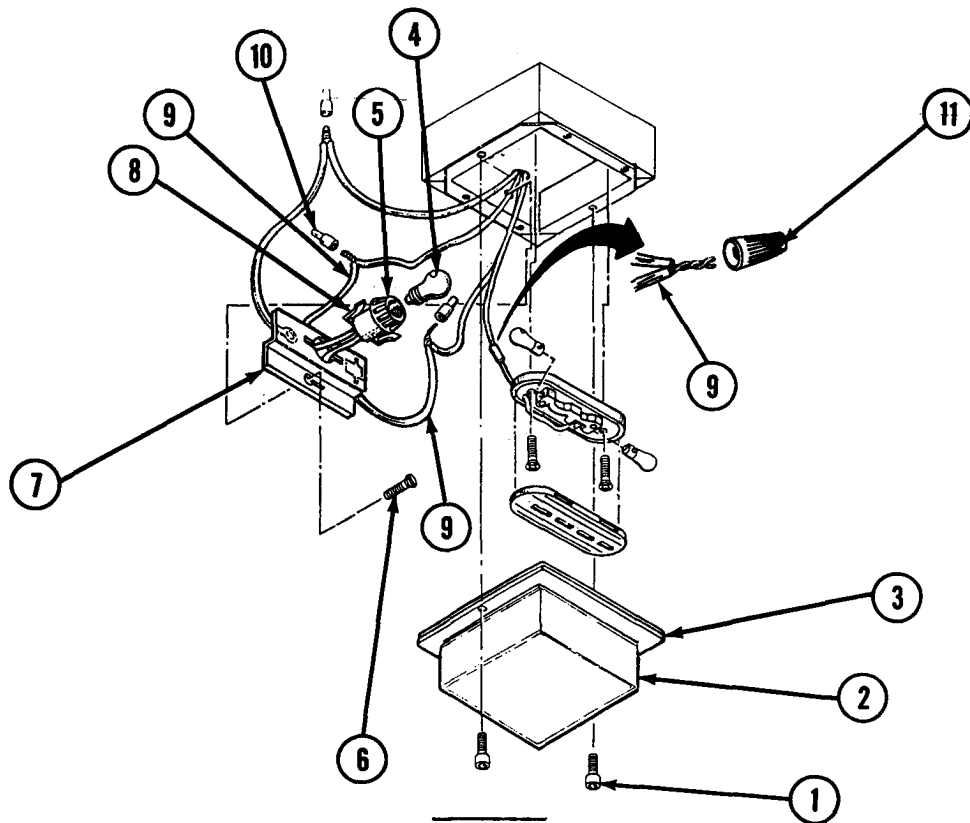

WARNING

ELECTRICAL HAZARD. Turn off power to blackout light system by setting blackout lights switch to off before repairing. Failure to observe this warning may result in death or serious injury.

1. Set BLACKOUT LIGHTS switch to OFF.
2. Remove thumbscrews (1). Remove blackout light cover (2) and foam gasket (3) from blackout light assembly.
3. Remove light bulb (4) from bulb socket (5).
4. Loosen screw (6) securing bulb socket bracket (7). Slip bracket (7) over screw (6) and partially remove from blackout light assembly.
5. Remove bulb socket (5) from bulb socket bracket (7) by squeezing metal retaining springs (8) and pulling outward.
6. Tag and cut two wires (9) above connectors (10).
7. Run wires from new bulb socket (5) through socket bracket (7) to blackout light assembly wires (9). Attach with new wire nuts (11).

2-52. REPAIR BLACKOUT LIGHT SYSTEM (CONT)

8. Snap bulb socket (5) into bulb socket bracket (7).
9. Position bulb socket bracket (7) over screw (6) and slip into position. Secure bracket (7) with screw (6).
10. Install light bulb (4).
11. Position foam gasket (3) on blackout light cover (2) and align holes.
12. Install blackout light cover (2) with thumbscrews (1).
13. To test operate, set BLACKOUT LIGHTS switch to ON (up) position. Then set BLACKOUT BYPASS switch to OFF (down) position and open personnel door.

MARKER LIGHTINITIAL SETUPTools

Light machine repair tool kit (appendix B, section III, item 11)
Flat-tip screwdriver
Cross-tip screwdriver
Pliers

Materials/Parts

Marker light, 77-556
Wire nut, 2978 (2 required)

2-52. REPAIR BLACKOUT LIGHT SYSTEM (CONT)

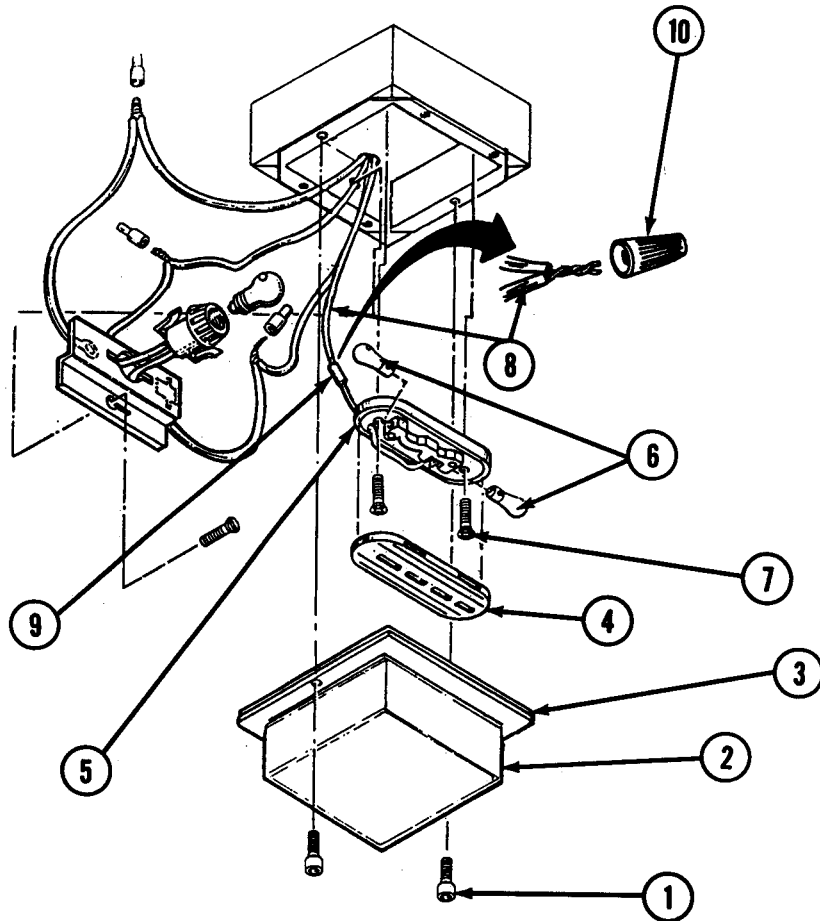

WARNING

ELECTRICAL HAZARD. Turn off power to blackout light system by setting blackout lights switch to off before repairing. Failure to observe this warning may result in death or serious injury.

1. Set BLACKOUT LIGHTS switch to OFF.
2. Remove thumbscrew (1). Remove blackout light cover (2) and foam gasket (3) from blackout light assembly.
3. Remove lens (4) from marker light (5) by inserting flat-tip screwdriver into slot and gently twisting.
4. Remove bulbs (6) by pressing in and turning.

2-52. REPAIR BLACKOUT LIGHT SYSTEM (CONT)

5. Remove screws (7) and marker light (5) from blackout light assembly.
6. Cut wire (8) above connector (9).
7. Connect wire from new marker light (5) to blackout light assembly wire (8) with new wire nut (10).
8. Install marker light (5) with screws (7).
9. Install light bulbs (6) by pushing in and turning.
10. Gently snap lens (4) onto marker light (5).
11. Position foam gasket (3) on blackout light cover (2) and align holes.
12. Install blackout light cover (2) with thumbscrews (1).
13. To test operate blackout light system, set BLACKOUT LIGHTS switch to ON (up) position. Then set BLACKOUT BYPASS switch to OFF (down) position and open personnel door.

DOOR SWITCHINITIAL SETUPTools

Light machine repair tool kit (appendix B, section III, item 11)
Flat-tip screwdriver
Extension light
Pliers
Crimping tool (appendix B, section III, item 14)

Materials/Parts

Switch, 4030
Electrical splice, NAS1388-2

2-52. REPAIR BLACKOUT LIGHT SYSTEM (CONT)

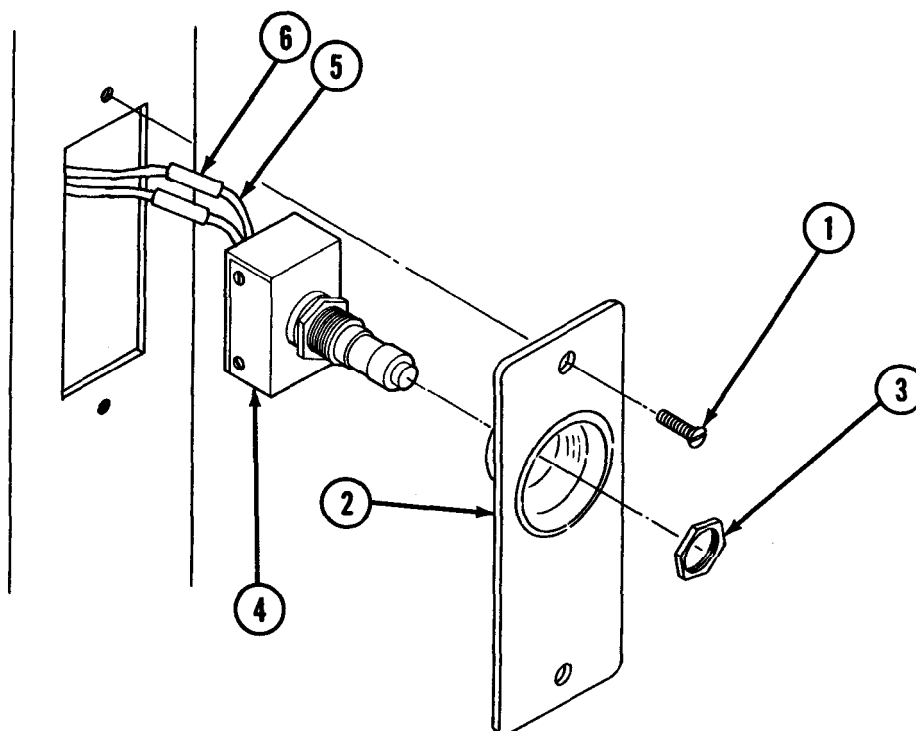

WARNING

ELECTRICAL HAZARD. Turn off main power switch before replacing door switch. Failure to do so may result in death or serious injury.

1. Set MAIN POWER switch to OFF.
2. Remove screws (1) securing door switch plate (2) to personnel door jamb.
3. Using needle-nose pliers, remove retaining nut (3) securing switch (4) to switch plate (2). Remove switch plate (2).
4. Cut two wires (5) above electrical splice (6) and remove switch.
- 5* Strip ends of wires (5) approximately 1/2 inch (1.3 cm) back from cut.
6. Connect wires from new switch (4) to wires (5) in door jamb with new electrical splice (6).

2-52. REPAIR BLACKOUT LIGHT SYSTEM (CONT)

7. Position switch plate (2) over switch (4) and secure with retaining nut (3).
8. Secure switch plate (2) with screws (1).
9. Set MAIN POWER switch to ON.
10. To test operate blackout light system, set BLACKOUT LIGHTS switch to ON (up) position. Then set BLACKOUT BYPASS switch to OFF (down) position and open personnel door.

RELAY

INITIAL SETUP

Tools

- Light machine repair tool kit (appendix B, section III, item 11)
- Flat-tip screwdriver
- Cross-tip screwdriver
- Extension light

Materials/Parts

Relay, PR011A40-120

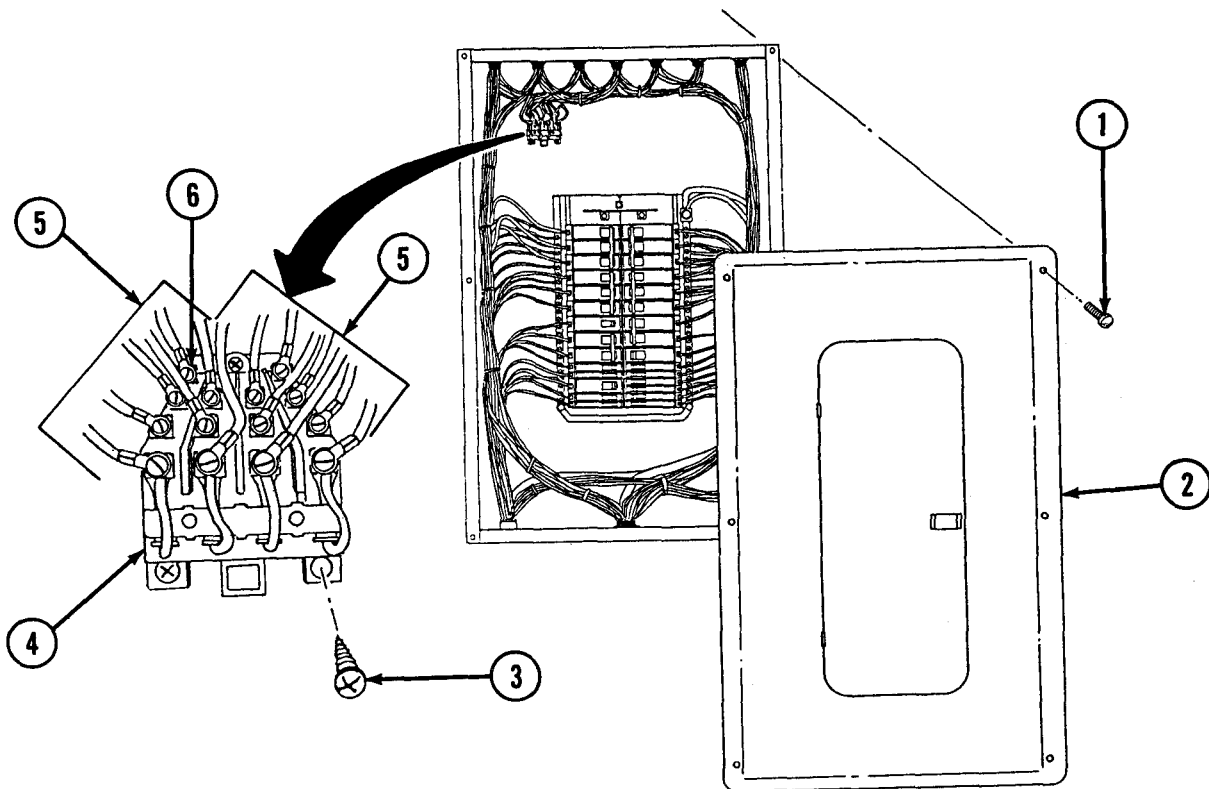

2-52. REPAIR BLACKOUT LIGHT SYSTEM (CONT)

WARNING

ELECTRICAL HAZARD. Turn off main power switch and disconnect main power cable before repairing blackout light system relay. Failure to do so may result in death or serious injury.

1. Set MAIN circuit breaker and MAIN POWER switch to OFF. Disconnect main power cable from Section.
2. Remove screws (1) and circuit breaker cover panel (2).
3. Remove three screws (3) securing relay (4) to back of circuit breaker box.

NOTE

For ease of installation, replacement of relay is wire-by-wire.

4. Before removing wires (5) from old relay (4), secure new relay (4) to back of circuit breaker box with three screws (3).
5. Starting at rear row of terminals (6), remove wire from old relay (4) and secure to new relay (4), one wire-at a time. Continue with remaining wires (5).
6. Install circuit breaker cover panel (2) with screws (1).

WARNING

ELECTRICAL HAZARD. Do not connect power cable to Section before grounding. Failure to observe this warning may result in death or serious injury.

7. Ground Section, connect main power cable, and set MAIN POWER switch and MAIN circuit breaker to ON.
8. To test operate blackout light system, set BLACKOUT LIGHTS switch to ON (up) position. Then set BLACKOUT BYPASS switch to OFF (down) position and open personnel door.

2-53. REPLACE DOME LIGHT ASSEMBLY

This task covers: a. Removal b. Installation

INITIAL SETUP

Tools

Light machine repair tool kit (appendix B, section III, item 11)
Cross-tip screwdriver
Pliers

Materials/Parts

Dome light assembly, 46583
Wire nut, 2978

REMOVAL

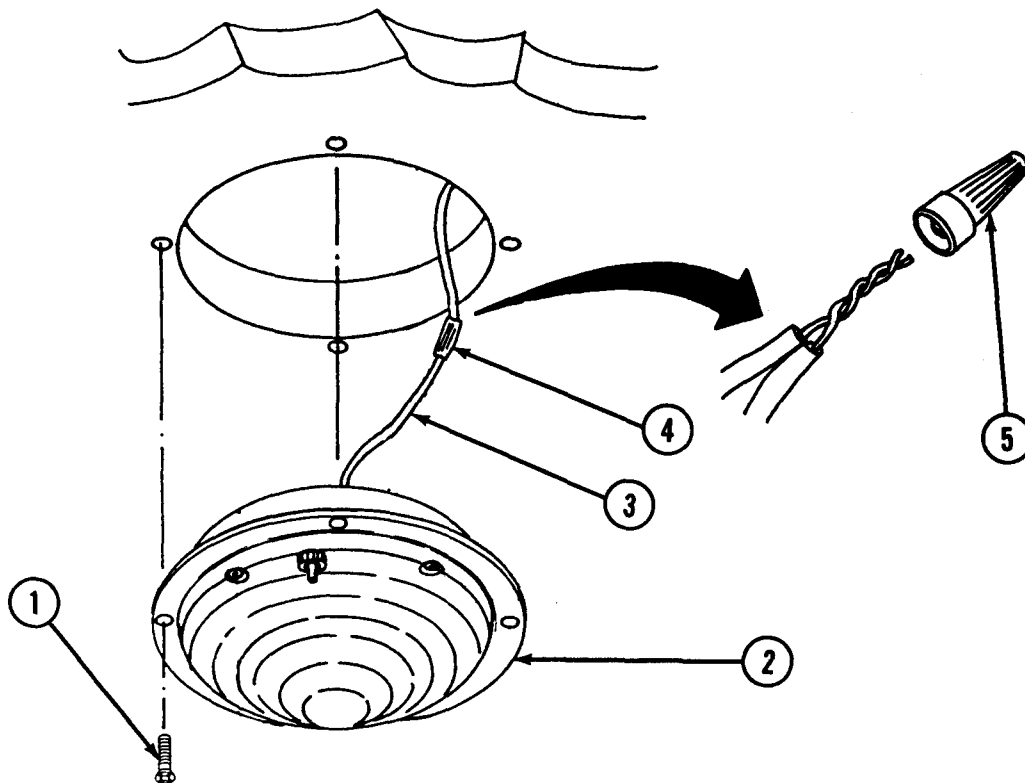

2-53. REPLACE DOME LIGHT ASSEMBLY (CONT)

WARNING

ELECTRICAL HAZARD. Disconnect Section from dc power supply before replacing dome light assembly. Failure to observe this warning may result in death or serious injury.

1. If necessary, disconnect Section from dc power supply.
2. Remove screws (1) securing dome light assembly (2) to ceiling and allow dome light assembly to hang by wire (3).
3. Cut wire (3) above connector (4) and remove dome light assembly (2).

INSTALLATION

1. Connect wire (3) to new dome light assembly (2) with wire nut (5).
2. Install dome light assembly (2) to ceiling with screws (1).
3. Connect 12-volt dc power source to Section and test operate dome light assembly.

2-54. REPAIR FLUORESCENT LIGHT

Fluorescent lights are repaired by replacing: a. Ballast
b. Diffuser panel

BALLAST

INITIAL SETUP

Tools

Light machine repair tool kit (appendix B, section III, item 11)
Flat-tip screwdriver
Wire cutter
Socket wrench set
Extension light

Materials/Parts

Lamp ballast, RQM-2540-3-TD
Wire nuts, 2978 (2 required)
Wire ties, 230425N (2 required)
Masking tape (appendix C, item 29)
Lead pencil (appendix C, item 13)
Electrical tape (appendix C, item 28)

2-54. REPAIR FLUORESCENT LIGHT (CONT)

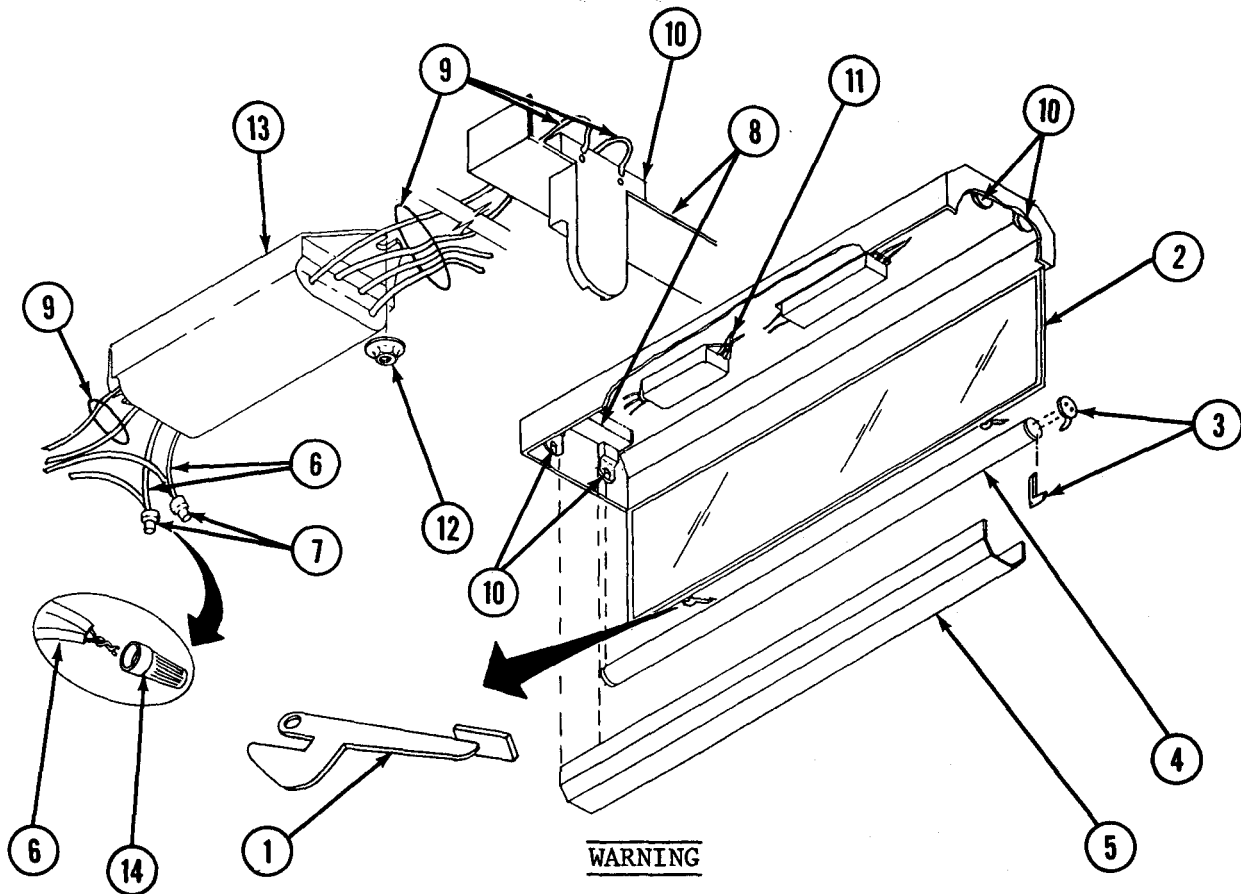

ELECTRICAL HAZARD. Turn off fluorescent light switch and ceiling circuit breaker before working on fluorescent lights. Failure to observe this warning may result in death or serious injury.

1. Set light switch and CEILING LIGHTS circuit breaker to OFF.
2. Release latches (1) and remove diffuser panel (2).
3. Remove safety latches (3) from fluorescent lamps (4).
4. Remove fluorescent lamps (4).
5. Remove wiring guard (5).
6. Tag and cut black and white wires (6) above wire connectors (7).
7. Remove lamp receptacle brackets (8).
8. Tag and remove wires (9) from receptacles (10).
9. Cut wire ties (11).

2-54. REPAIR FLUORESCENT LIGHT (CONT)

10. Remove hex nuts (12) and lamp ballast (13).
11. Install new lamp ballast (13) with hex nuts (12).
12. Install wires (9) on receptacles (10).
13. Install receptacle brackets (8).
14. Install black and white wires (6) with wire nuts (14).
15. Install wire ties (11) and wrap wires with electrical tape as needed.
16. Install wiring guard (5).
17. Install fluorescent lamps (4).
18. Install safety latches (3).
19. Install diffuser panel (2) with latches (1).
20. Set CEILING LIGHTS circuit breaker to ON. Test operate by setting light switch to ON.

DIFFUSER PANEL

INITIAL SETUP

Tools

Light machine repair tool kit (appendix B, section III, item 11)
Cross-tip screwdriver

Materials/Parts

Diffuser panel insert

2-54. REPAIR FLUORESCENT LIGHT (CONT)

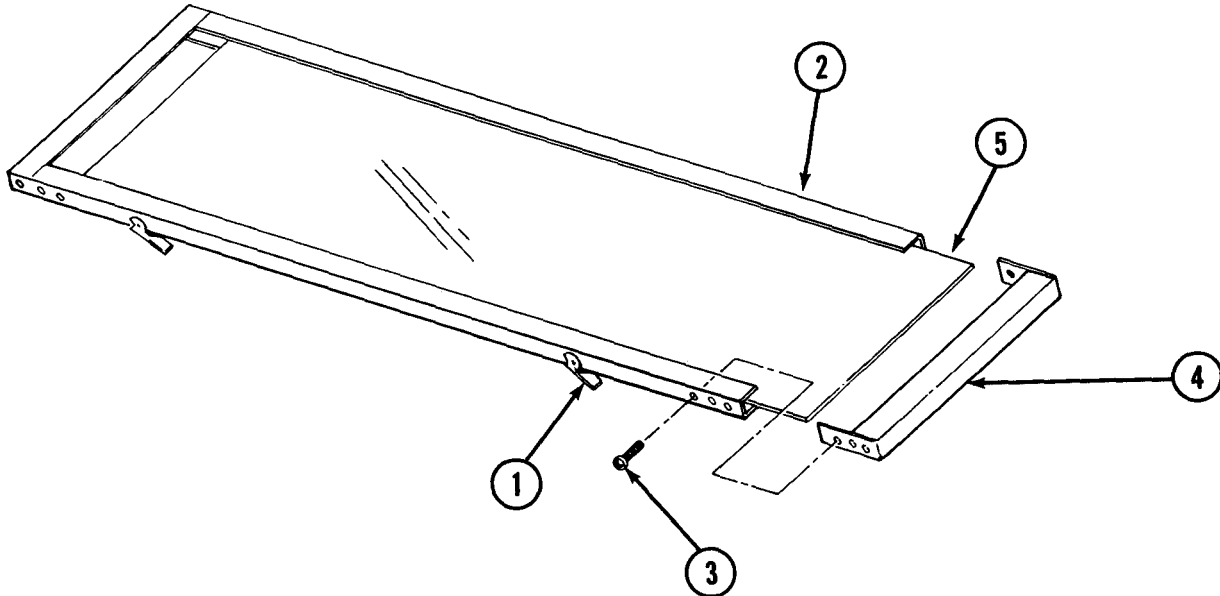

1. Release latches (1) and open fluorescent light diffuser panel (2).
2. Remove panel (2) from light fixture.
3. Remove screws (3) and end piece (4).
4. Slide out diffuser panel insert (5).
5. Slide new diffuser panel insert (5) in panel (2) and secure end piece (4) with screws (3).
6. Install diffuser panel (2).
7. Close panel (2) and secure with latches (1).

2-55. REPLACE ON/OFF SWITCH

This task covers: a. Removal b. Installation

INITIAL SETUP

Tools

Light machine repair tool kit (appendix B, section III, item 11)
 Flat-tip screwdriver

2-55. REPLACE ON/OFF SWITCH(CONT)

Materials/Parts

- Switch, 7083K12
- Lead pencil (appendix C, item 13)
- Masking tape (appendix C, item 29)

REMOVAL

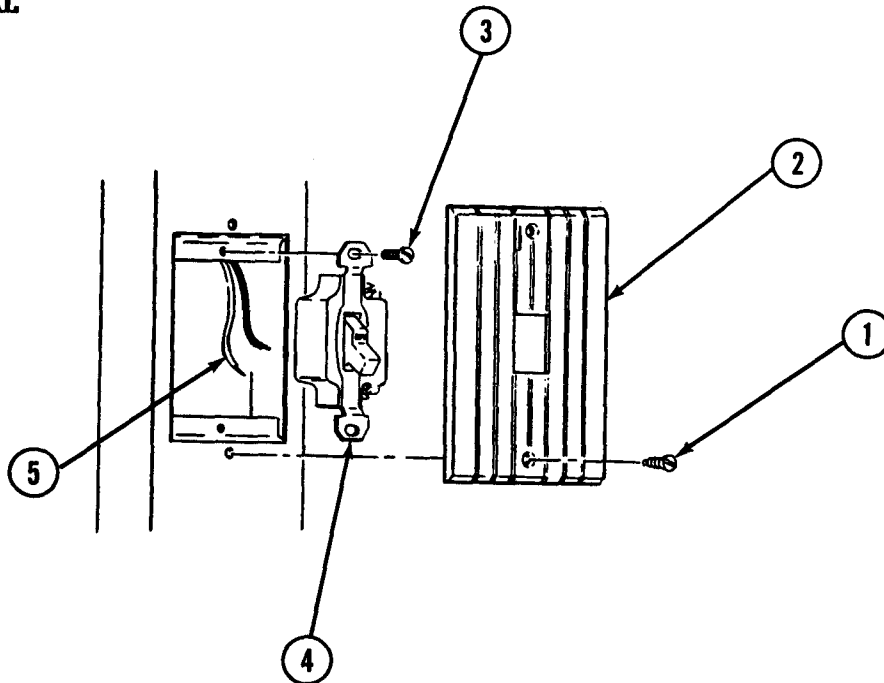

WARNING

ELECTRICAL HAZARD. Turn switch and circuit breaker off before replacing switch. Failure to observe this warning may result in death or serious injury.

1. Set ON/OFF switch and appropriate circuit breaker to OFF.
2. Remove screws (1) and cover plate (2).
3. Remove mounting screws (3) and partially remove switch (4).
4. Tag and remove wires (5) from terminals on switch (4).
5. Remove switch (4).

INSTALLATION

1. Install wires (5) on terminals of new switch (4).
2. Install switch (4) with mounting screws (3).

2-55. REPLACE ON/OFF SWITCH (CONT)

3. Install cover plate (2) with screws (1).
4. Set circuit breaker to ON.
5. Test operate.

2-56. REPLACE WALL OUTLET

This task covers: a. Removal b. Installation

INITIAL SETUP

Tools

- Light machine repair tool kit (appendix B, section III, item 11)
- Flat-tip screwdriver

Materials/Parts

- Duplex receptacle, 5739
- Lead pencil (appendix C, item 13)
- Masking tape (appendix C, item 29)

REMOVAL

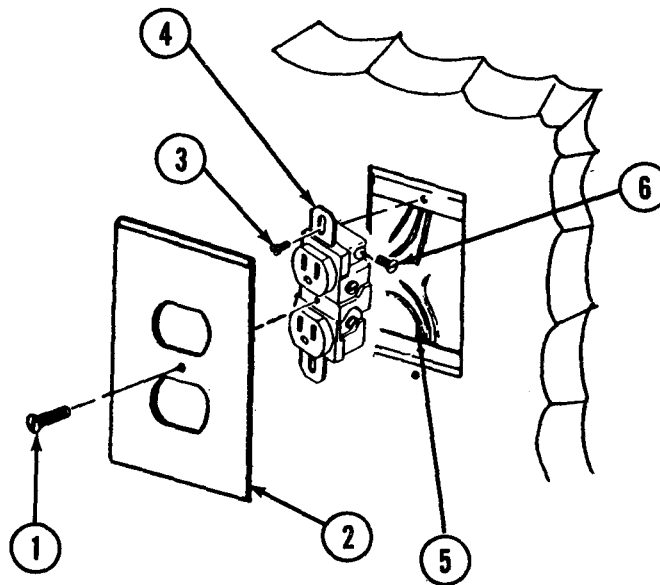

2-56. REPLACE WALL OUTLET (CONT)

1. Unplug appliances connected to wall outlet.

WARNING

ELECTRICAL HAZARD. Turn off wall outlet circuit breaker before replacing wall outlet. Use multimeter to be sure power is off. Failure to observe this warning may result in death or serious injury.

2. Set appropriate wall outlet circuit breaker to OFF. Use multimeter to ensure power is off.
3. Remove screw (1) and cover plate (2).
4. Remove mounting screws (3) and partially remove wall outlet (4).

NOTE

Electrical wires may be secured with screws or plugged into terminals. Ground wires will always be secured by screws.

5. Tag and disconnect wires (5) from terminals and ground screws (6).
6. Remove wall outlet (4).

INSTALLATION

1. Connect wires (5) to terminals and ground screw (6) on new wall outlet.
2. Install new wall outlet (4) with two mounting screws (3).
3. Install cover plate (2) with screw (1).
4. Set wall outlet circuit breaker to ON.
5. Test operate by plugging in and operating appliance.

2-57. REPLACE EXHAUST FAN ASSEMBLY

This task covers: a. Removal b. Installation

INITIAL SETUP

Tools

Light machine repair tool kit (appendix B, section III, item 11)
Flat-tip screwdriver
Cross-tip screwdriver

2-57. REPLACE EXHAUST FAN ASSEMBLY (CONT)

Materials/Parts

- Exhaust fan assembly, 13227E6274
- Masking tape (appendix C, item 29)
- Lead pencil (appendix C, item 13)

REMOVAL

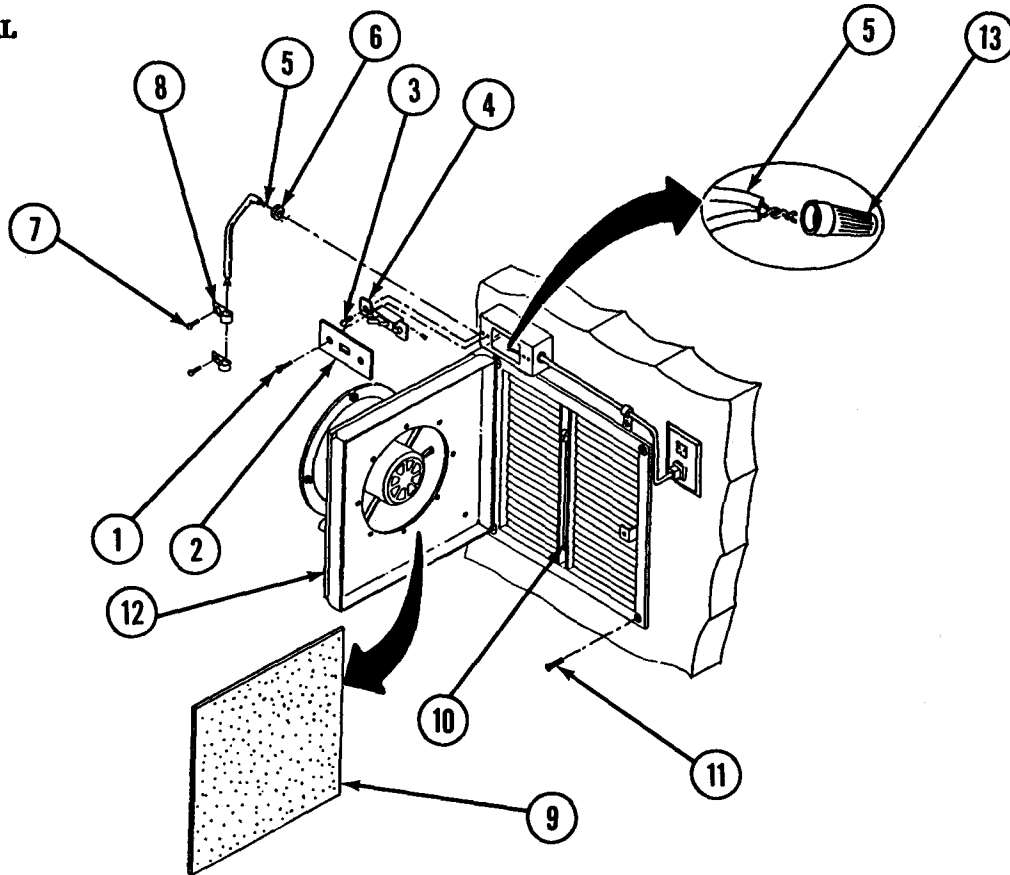

WARNING

ELECTRICAL HAZARD. Turn off exhaust fan and disconnect power cord before working on exhaust fan. Death or serious injury could result if power is on.

1. Set exhaust fan switch to OFF and unplug power cord.
2. Remove screws (1) and switch cover (2).
3. Remove screws (3) and partially remove switch (4).
4. Tag and disconnect wires (5). Untie knot in wiring and pull wire through grommet (6).

2-57. REPLACE EXHAUST FAN ASSEMBLY (CONT)

5. Remove screws (7) and clamps (8).
6. Open assembly door, remove foam filter (9), and check external exhaust fan door latch (10) to ensure that latch is not hooked.
7. Remove screws (11) and exhaust fan assembly (12).

INSTALLATION

1. Position external exhaust fan door latch (10) through slot in new exhaust fan assembly (12). Install assembly (12) with screws (11).
2. Install foam filter (9) in exhaust fan assembly door and secure door.
3. Install clamps (8) with screws (7).
4. Thread wires (5) through grommet (6) and tie knot in wires.
5. Connect black wire (5) to switch (4). Connect white wire (5) and secure with wire nut (13).
6. Install switch (4) with screws (3).
7. Install plate cover (2) with screws (1).
8. Plug power cord into wall outlet.
9. To test operate, open exterior exhaust fan door and set exhaust fan switch to ON.

2-58. REPAIR EXHAUST FAN ASSEMBLY

Exhaust fan assembly is repaired by replacing: Fan

FAN

INITIAL SETUP

Tools

Light machine repair tool kit (appendix B, section III, item 11)
Cross-tip screwdriver
Flat-tip screwdriver
Combination wrench set

Materials/Parts

Fan, 13222E4374
Masking tape (appendix C, item 29)
Lead pencil (appendix C, item 13)

2-58. REPAIR EXHAUST FAN ASSEMBLY (CONT)

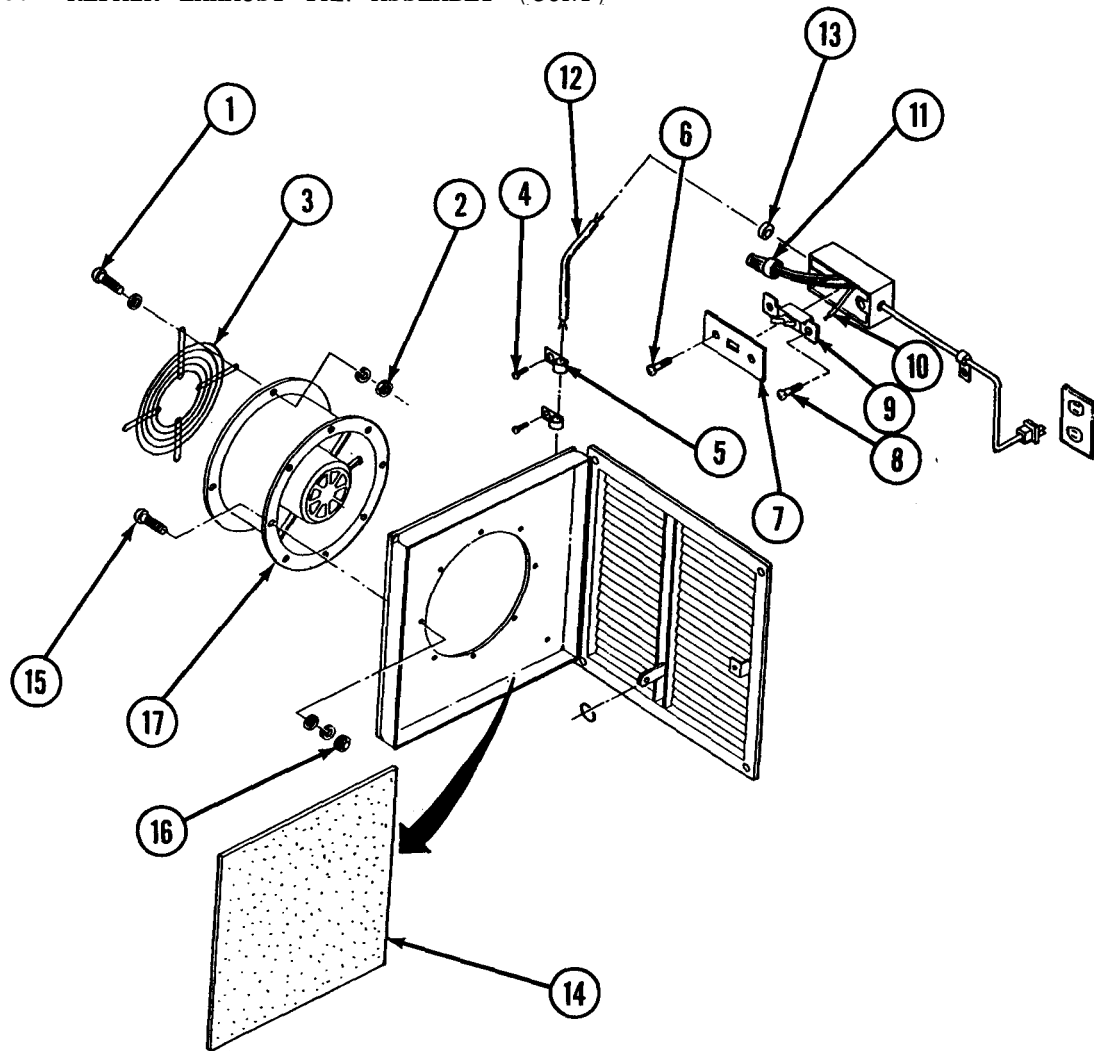
**WARNING**

ELECTRICAL HAZARD. Turn off exhaust fan switch and disconnect power cord before working on exhaust fan. Death or serious injury may result if power is on.

1. Set exhaust fan switch to OFF and unplug power cord.
2. Remove screws (1), flatwashers, lockwashers, hex nuts (2), and fan guard (3).
3. Remove screws (4) and cable clamps (5).
4. Remove screws (6) and switch cover (7).
5. Remove screws (8) securing switch (9).

2-58. REPAIR EXHAUST FAN ASSEMBLY (CONT)

6. Tag and remove wires (10) on terminals of switch (9).
7. Remove wire nut (11) from wires (10).
8. Untie knot in cable (12) and remove from receptacle box by gently pulling through grommet (13).
9. Open exhaust fan door. Remove foam filter (14).
10. Remove screws (15), flatwashers, lockwashers, hex nuts (16), and fan (17).
11. Install new fan (17) with screws (15), flatwashers, lockwashers, and hex nuts (16).
12. Install fan guard (3) with screws (1), flatwashers, lockwashers, and hex nuts (2).
13. Install two cable clamps (5) with screws (4).
14. Thread cable (12) through grommet (13) on receptacle box. Tie knot in cable to prevent cable from being pulled through grommet (13).
15. Connect wire (10) with wire nut (11). Secure wires (10) to switch (9).
16. Install switch (9) with screws (8).
17. Install switch cover (7) with screws (6).
18. Install foam filter (14), open exterior door, and close exhaust fan door.
19. Plug power cord into wall outlet.
20. To test operate, set exhaust fan switch to ON.

2-59. REPLACE WALL HEATER

This task covers: a. Removal b. Installation

INITIAL SETUP

Tools

- Light machine repair tool kit (appendix B, section III, item 11)
- Cross-tip screwdriver
- Pliers
- Crimping tool (appendix B, section III, item 14)

2-59. REPLACE WALL BEATER (CONT)

Materials/Parts

- Wall heater, LWA2440-D
- Wire nuts, 2978 (2 required)
- Masking tape (appendix C, item 29)
- Lead pencil (appendix C, item 13)

REMOVAL

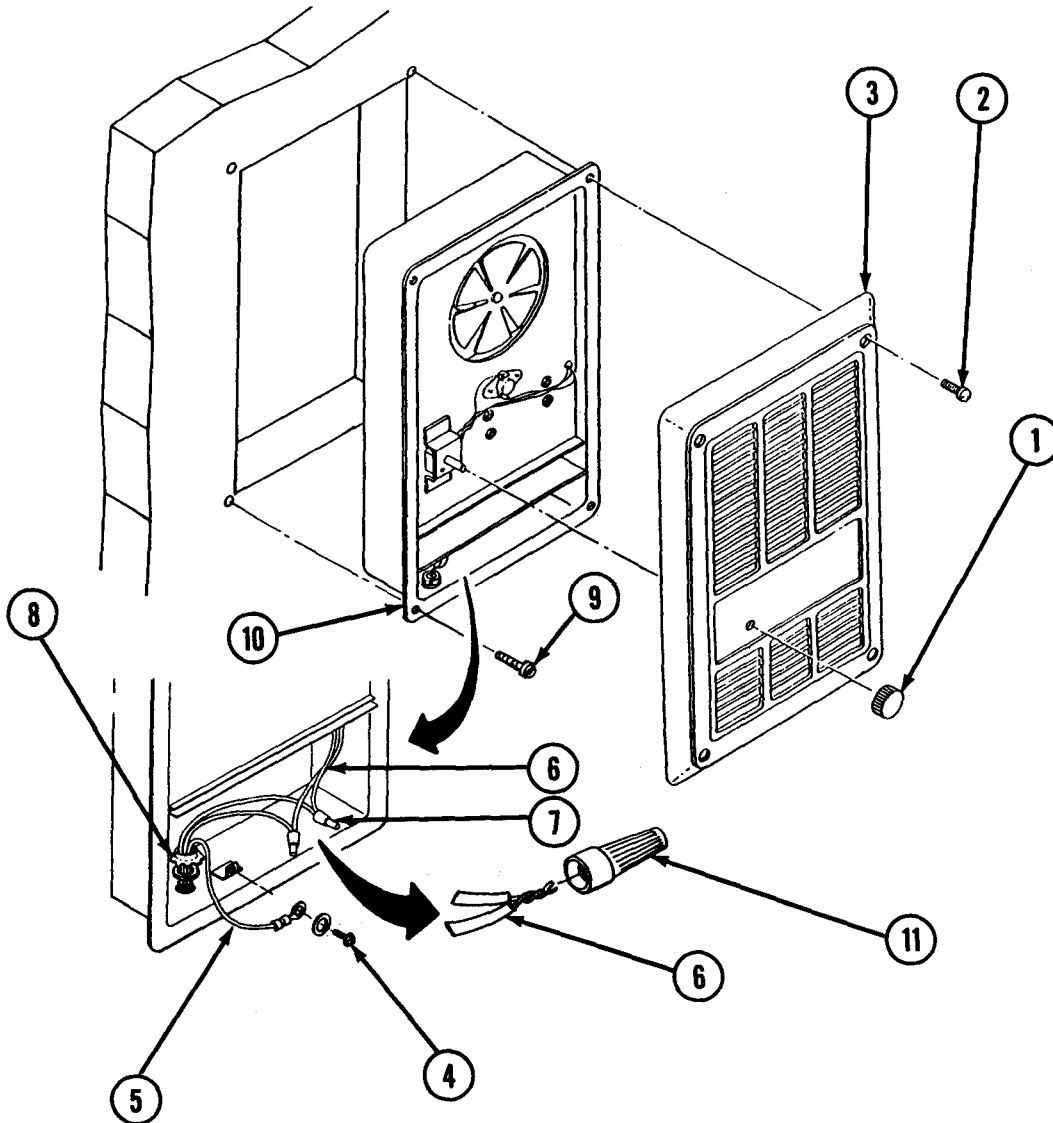

2-59. REPLACE WALL HEATER (CONT)

WARNING

- ELECTRICAL HAZARD. There are two heater circuit breakers. Set specific circuit breaker for wall heater being replaced to off. Failure to observe this warning may result in death or serious injury.
- Do not operate wall heater with grill removed or with wall heater removed from enclosure. Serious personal injury may result.

1. Set specific HEATER circuit breaker to OFF.
2. Remove control knob (1) by pulling gently.

WARNING

Grill may fall when last screw is removed. Failure to hold grill with free hand may result in personal injury.

3. Remove screws (2) and grill (3).
4. Remove screw (4), cupped washer, and wire (5).
5. Tag wires (6) and cut below connections (7).
6. Remove conduit locknut (8) and washer.
7. Remove screws (9) and wall heater (10) from Section wall, pulling wires (5) and (6) through housing.

INSTALLATION

1. Insert wires (5) and (6) through new wall heater housing and install wall heater (10) on Section wall with screws (9).
2. Install washer and conduit locknut (8).
3. Connect wires (6) and secure with new wire nuts (11).
4. Install wide (5) with cupped washer and screw (4).
5. Install grill (3) with screws (2).
6. Install control knob (1).

2-59. REPLACE WALL HEATER (CONT)

7. Set HEATER circuit breaker to ON.
8. Test operate wall heater by turning control knob to right.

2-60. REPAIR WALL HEATER

Wall heaters are repaired by replacing: a. Limiting thermostat
 b. Thermostat c. Element assembly d. Fan motor

LIMITING THERMOSTAT

INITIAL SETUP

Tools

- Light machine repair tool kit (appendix B, section III, item 11)
- Cross-tip screwdriver

Materials/Parts

- Limiting thermostat, 42545-003-01
- Masking tape (appendix C, item 29)
- Lead pencil (appendix C, item 13)

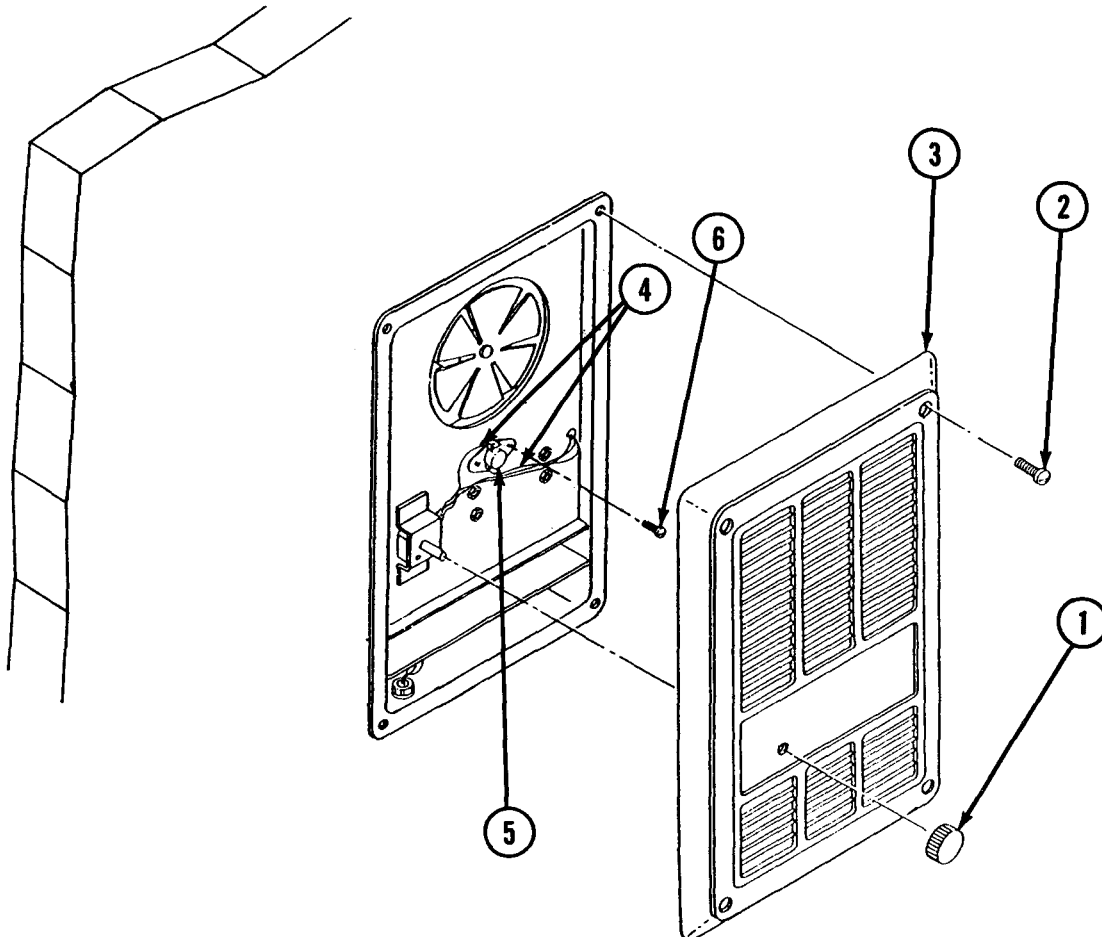

2-60. REPAIR WALL HEATER (CONT)

WARNING

- ELECTRICAL HAZARD. There are two heater circuit breakers. Set specific circuit breaker for wall heater being repaired to off. Failure to observe this warning may result in death or serious injury.
- Do not operate wall heater with grill removed or with wall heater assembly removed from enclosure. Serious personal injury may result.

1. Set specific HEATER circuit breaker to OFF.
2. Remove control knob (1) by pulling gently.

WARNING

Grill may fall when last screw is removed. Failure to hold grill with free hand may result in serious personal injury.

3. Remove screws (2) and grill (3).
4. Tag and disconnect wires (4) on limiting thermostat (5).
5. Remove screws (6) and limiting thermostat (5).
6. Install new limiting thermostat (5) with screws (6).
7. Connect wires (4) to limiting thermostat (5).
8. Install grill (3) with screws (2).
9. Install control knob (1).
10. Set HEATER circuit breaker to ON.
11. Test operate wall heater by turning control knob to right.

2-60. REPAIR WALL HEATER (CONT)

THERMOSTAT

INITIAL SETUP

Tools

- Light machine repair tool kit (appendix B, section III, item 11)
- Cross-tip screwdriver
- Portable electric drill
- Twist drill set
- Pliers
- Rivet gun (appendix B, section III, item 10)

Materials/Parts

- D-option thermostat, 42523-006-03
- Rivet, MS20600AD4W4 (2 required)
- Masking tape (appendix C, item 29)
- Lead pencil (appendix C, item 13)

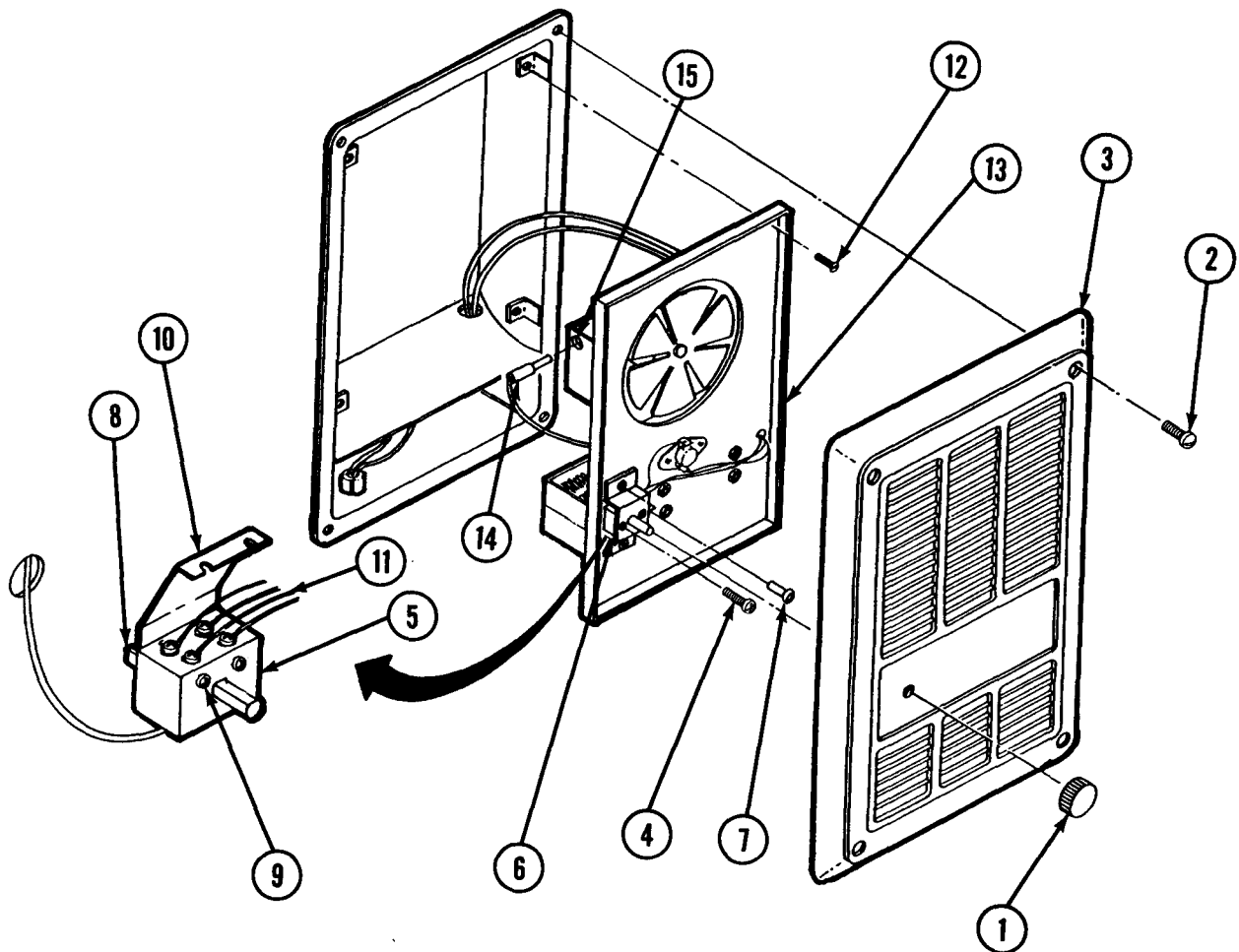

2-60. REPAIR WALL HEATER (CONT)

WARNING

- ELECTRICAL HAZARD. There are two heater circuit breakers. Set specific circuit breaker for wall heater being repaired to off. Failure to do so may result in death or serious injury.
- Do not operate wall heater with grill removed or with wall heater assembly removed from enclosure. Serious personal injury may result.

1. Set specific HEATER circuit breaker to OFF.
2. Remove control knob (1) by pulling gently.

WARNING

Grill may fall when last screw is removed. Failure to hold grill with free hand may result in serious personal injury.

3. Remove screws (2) and grill (3).
4. Remove screws (4) securing thermostat (5) to bracket (6).
5. Drill out rivets (7) and remove bracket (6).
6. Hold hex nuts (8) and loosen, but do not remove screws (9).
7. Remove insulator (10).
8. Tag and disconnect wires (11).
9. Remove screws (12) and tilt out top of interior assembly (13).
10. Remove probe (14) from grommet (15) and remove thermostat (5).

CAUTION

Do not bend copper tubing when inserting probe in grommet. Bending will break copper tubing.

11. Thread new probe (14) through hole in interior assembly (13) and install in grommet (15).
12. Install interior assembly (13) with screws (12).
13. Install wires (11) on new thermostat (5).

2-60. REPAIR WALL HEATER (CONT)

14. Install insulator (10). Holding hex nuts (8), secure screws (9).
15. Install bracket (6) on thermostat (5) with screws (4).
16. Install bracket (6) on interior assembly (13) with rivets (7).
17. Install grill (3) with screws (2).
18. Install control knob (1).
19. Set HEATER circuit breaker to ON.
20. Test operate wall heater by turning control knob to right.

ELEMENT ASSEMBLY

INITIAL SETUP

Tools

Light machine repair tool kit (appendix B, section III, item 11)
Cross-tip screwdriver
Pliers

Materials/Parts

Element assembly, 42523-004-54
Masking tape (appendix C, item 29)
Lead pencil (appendix C, item 13)

2-60. REPAIR WALL HEATER (CONT)

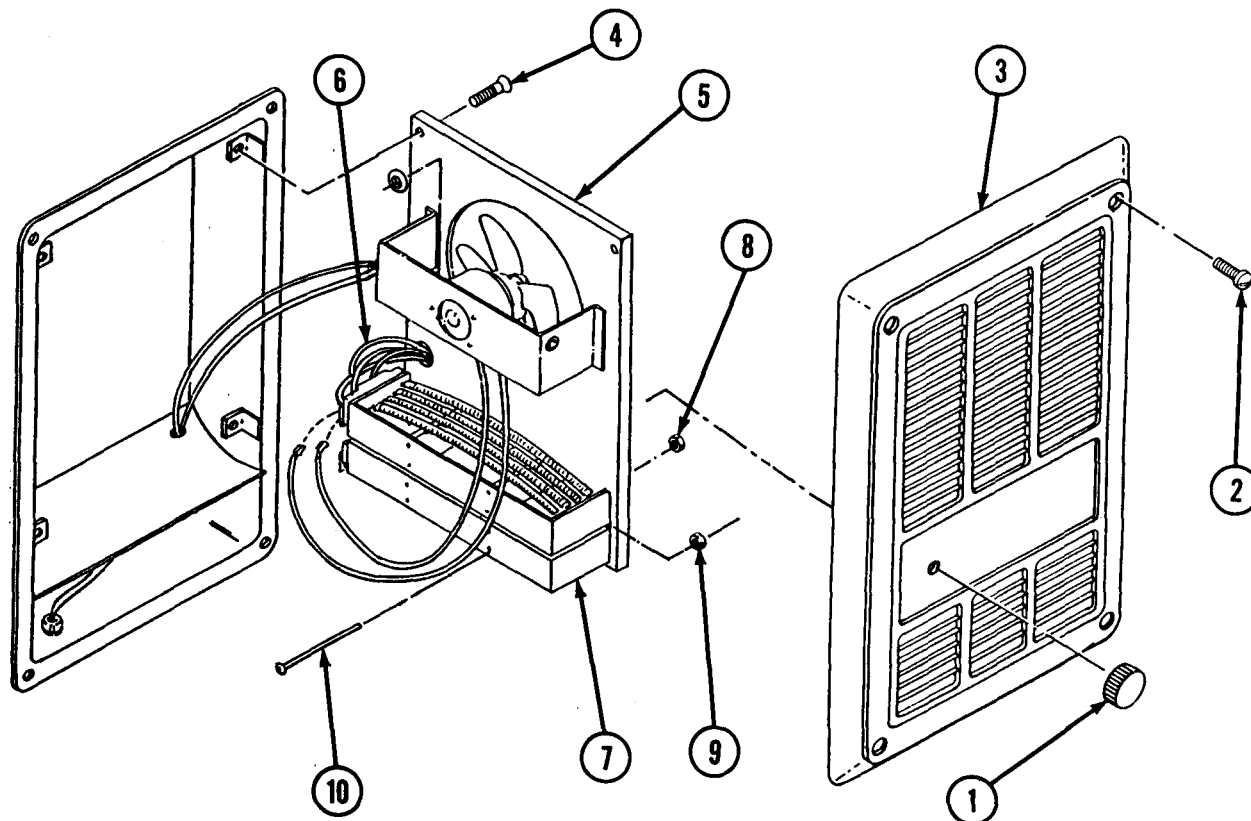

WARNING

- ELECTRICAL HAZARD. There are two heater circuit breakers. Set specific circuit breaker for wall heater being repaired to off. Failure to observe this warning may result in death or serious injury.
- Do not operate wall heater with grill removed or with wall heater assembly removed from enclosure. Failure to observe this warning may result in serious personal injury.

1. Set specific HEATER circuit breaker to OFF.
2. Remove control knob (1) by pulling gently.

2-60. REPAIR WALL HEATER (CONT)**WARNING**

Grill may fall when last screw is removed. Failure to hold grill with free hand may result in personal injury.

3. Remove screws (2) and grill (3).
4. Remove screws (4) and partially remove interior assembly (5).
5. Tag and remove wires (6) from element assembly (7).
6. Remove keps nuts (8) and element assembly (7) from interior assembly (5).
7. Remove hex nuts (9) and bolts (10) from element assembly (7).
8. Install bolts (10) and hex nuts (9) on new element assembly (7).
9. Install new element assembly (7) with keps nuts (8).
10. Connect wires (6) to element assembly (7).
11. Secure interior assembly (5) with screws (4).
12. Install grill (3) with screws (2).
13. Install control knob (1).
14. Set HEATER circuit breaker to ON.
15. Test operate wall heater by turning control knob to right.

FAN MOTOR**INITIAL SETUP****Tools**

Light machine repair tool kit (appendix B, section III, item 11)
 Flat-tip screwdriver
 Cross-tip screwdriver

Materials/Parts

208/240-volt motor, 42523-020-02
 Masking tape (appendix C, item 29)
 Lead pencil (appendix C, item 13)

2-60. REPAIR WALL HEATER (CONT)

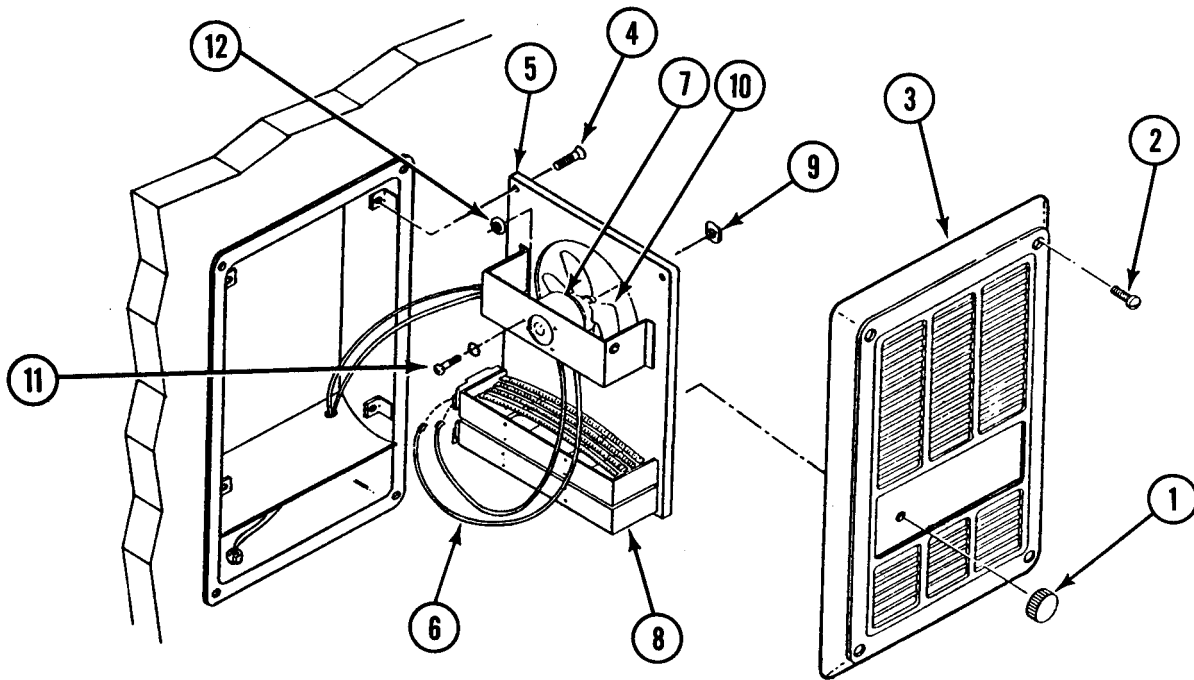

WARNING

●ELECTRICAL HAZARD. There are two heater circuit breakers. Set specific circuit breaker for wall heater being repaired to off. Failure to observe this warning may result in death or serious injury.

●Do not operate wall heater with grill removed or with wall heater assembly removed from enclosure. Serious personal injury may result.

1. Set specific HEATER circuit breaker to OFF.
2. Remove control knob (1) by pulling gently.

WARNING

Grill may fall when last screw is removed. Failure to hold grill with free hand may result in personal injury.

3. Remove screws (2) and grill (3).

2-60. REPAIR WALL HEATER (CONT)

4. Remove screws (4) and partially remove interior assembly (5).
5. Disconnect wires (6) leading from fan motor (7) on element assembly (8).
6. Remove retaining nut (9) and fan blade (10).
7. Remove screws (11), starwashers, rubber grommets (12), and fan motor (7).
8. Install new fan motor (7) with rubber grommets (12), starwashers, and screws (11).
9. Install fan blade (10) with retaining nut (9).
10. Connect wires (6) to element assembly (8).
11. Install interior assembly (5) with screws (4).
12. Install grill (3) with screws (2).
13. Install control knob (1).
14. Set HEATER circuit breaker to ON.
15. Test operate wall heater by turning control knob to right.

2-61. REPAIR EXPANDING SIDE POWER CABLE

Expanding side power cable is repaired by replacing a. Power cable connector b. Power cable

POWER CABLE CONNECTORINITIAL SETUPTools

Light machine repair tool kit (appendix B, section III, item 11)
 Soldering gun
 Solder
 Flat-tip screwdriver

Materials/Parts

Power cable connector, MS31088-28-20P (curbside)
 Power cable connector, MS31088-22-23P (roadside)
 Masking tape (appendix C, item 29)
 Lead pencil (appendix C, item 13)
 Electrical tape (appendix C, item 28)

2-61. REPAIR EXPANDING SIDE POWER CABLE (CONT)

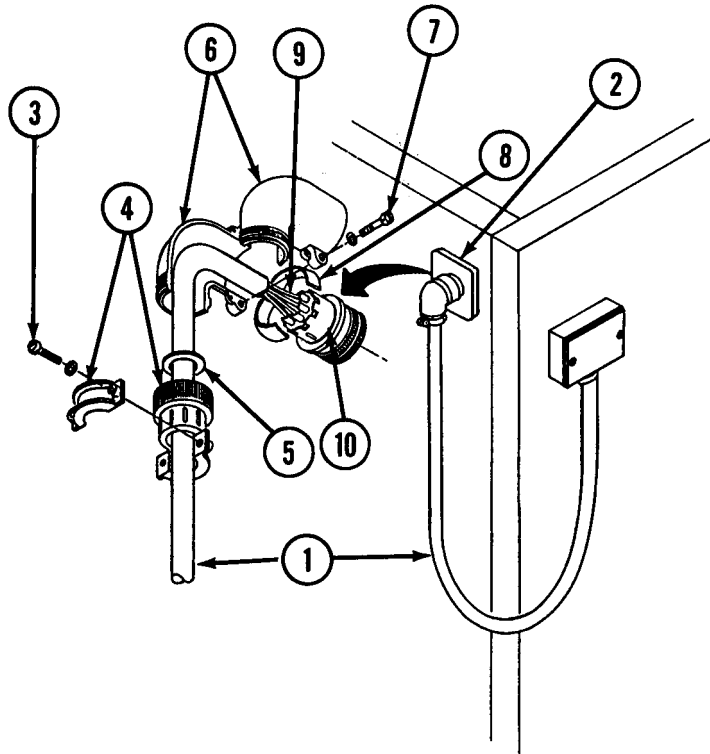

WARNING

ELECTRICAL HAZARD. Turn off main power switch before connecting or disconnecting expanding side power cable. Failure to do so may result in death or serious injury.

NOTE

Curbside and roadside expanding side power cable connectors are not identical.

1. Set MAIN POWER switch to OFF.
2. Disconnect expanding side power cable (1) from wall receptacle (2).
3. Set MAIN POWER switch to ON.
4. Remove screws (3) and lockwashers on strain relief clamp (4).
5. Unscrew strain relief clamp (4) and seal (5). Separate from connector housing (6).

2-61. REPAIR EXPANDING SIDE POWER CABLE (CONT)

6. Remove screws (7) and lockwashers. Separate each section of connector housing (6).
7. Remove wire covering (8). Tag and desolder wires (9) from terminal pin assembly (10). Remove pin assembly (10).
8. Remove seal (5) and strain relief clamp (4).
9. Install new strain relief clamp (4) and new seal (5) on cable (1).
10. Solder wires (9) to new pin assembly (10) and install new wire covering (8).
11. Place new connector housing (6) over new pin assembly (10) and install with screws (7) and lockwashers.
12. Install strain relief clamp (4) on connector housing (6).
13. Install screws (3) and lockwashers on strain relief clamp (4).

WARNING

ELECTRICAL HAZARD. Turn off MAIN POWER switch before connecting or disconnecting expanding side power cable. Failure to do so may result in death or serious injury.

14. Set MAIN POWER switch to OFF.
15. Connect expanding side cable (1) on wall receptacle (2).
16. Set MAIN POWER switch to ON.
17. To test operate, set all expanding side circuit breakers to ON and operate equipment.

POWER CABLE**INITIAL, SETUP****Tools**

Light machine repair tool kit (appendix B, section III, item 11)
 Solder gun
 Solder
 Flat-tip screwdriver
 Extension light

2-61. REPAIR EXPANDING SIDE POWER CABLE (CONT)

Materials/Parts

- Power cable, M3872
- Power cable, M3874
- Terminal ends (10 required)
- Masking tape (appendix C, item 29)
- Lead pencil (appendix C, item 13)
- Electrical tape (appendix C, item 28)

Equipment Conditions

Power cable connectors removed (a, this para)

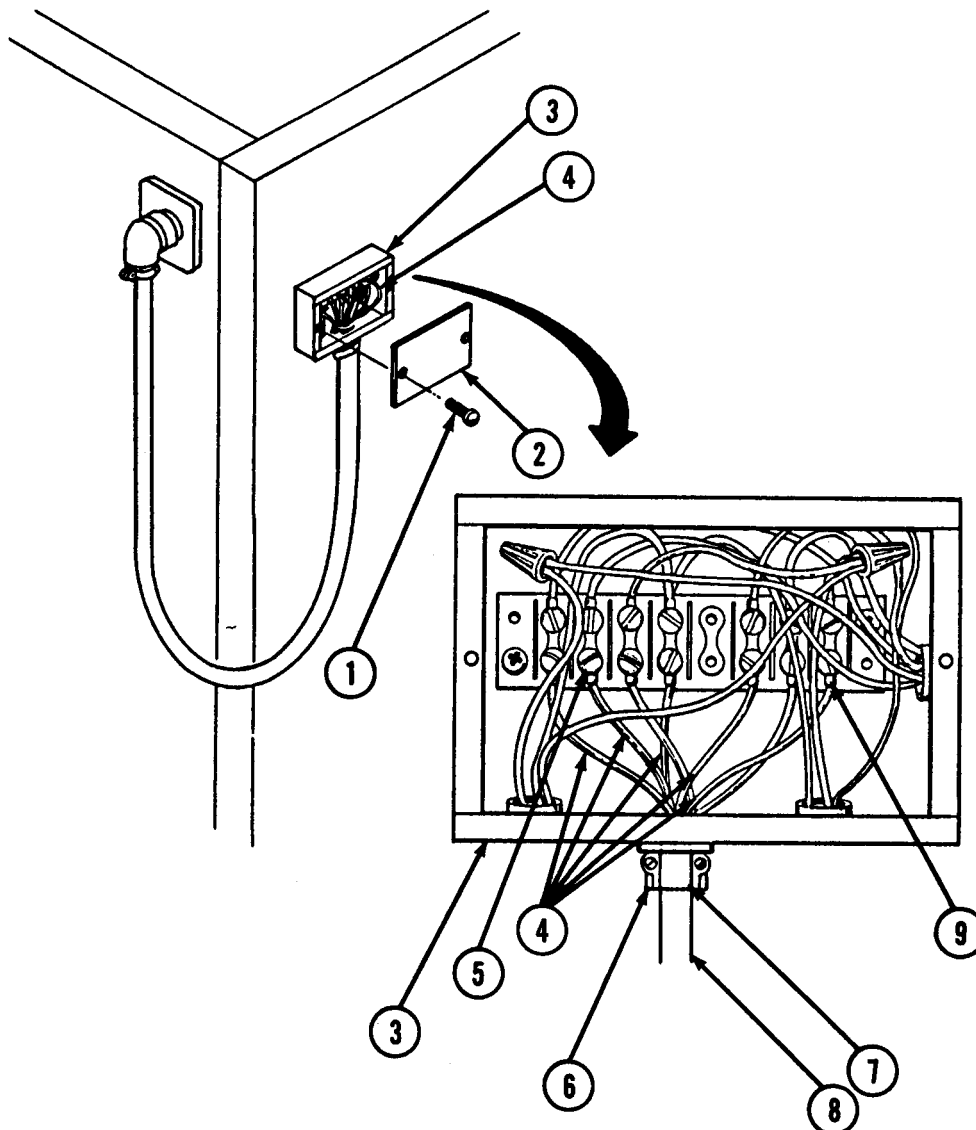

2-61. REPAIR EXPANDING SIDE POWER CABLE (CONT)WARNING

ELECTRICAL HAZARD. Turn off main power switch before connecting or disconnecting expanding side power cable. Failure to do so may result in death or serious injury.

NOTE

Curbside and roadside expanding side power cable connectors are not identical.

1. Set MAIN POWER switch to OFF.
2. Loosen screws (1) securing cover plate (2) to junction box (3).
3. Tag and disconnect wires (4) from junction box terminals (5).
4. Loosen screws (6) securing strain relief clamp (7) to junction box (3). Remove power cable (8).
5. Pull power cable (8) through strain relief clamp (7).
6. Install new power cable (8) through strain relief clamp (7).
7. Tighten screws (6) securing strain clamp (7).
8. Install new terminal ends (9) on wires (4).
9. Connect wires (4) to junction box terminals (5).
10. Install cover plate (2) with screws (1).
11. Install power cable connector (a, this para).

2-62. REPAIR SECTION BODY SKIN (TEMPORARY)

Section body skin is temporarily repaired with tape.

INITIAL SETUPMaterials/Parts

- Rag (appendix C, item 24)
- Duct tape (appendix C, item 27)
- Silicone compound (appendix C, item 7)

2-62. REPAIR SECTION BODY SKIN (TEMPORARY) (CONT)

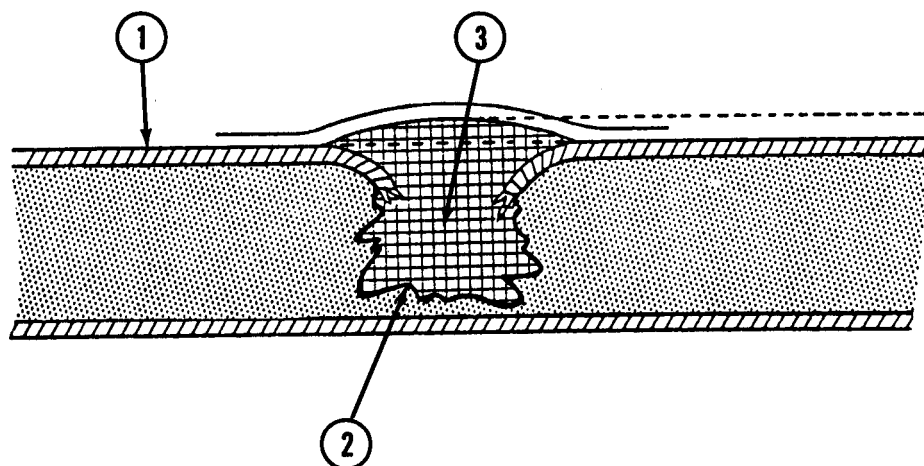

WARNING

Do not attempt to remove body skin fragments by bending, pulling, or cutting. Failure to observe this warning may result in injury to personnel or further damage to equipment.

NOTE

This procedure is for temporary repair only. For permanent repair, refer equipment to direct support/general support maintenance.

1. Bend broken edges of Section body skin (1) into puncture (2).
2. Remove loose fragments of foam (3).
3. Clean area around puncture (2) with rag and water.

WARNING

CHEMICAL HAZARD. Use silicone compound in a well-ventilated area. Silicone compound is harmful to eyes and skin. In case of contact with eyes, Immediately flush eyes with water for 15 minutes, then seek medical help. In case of contact with skin, wipe off with dry cloth, then wash with soap and water.

4. Apply silicone compound in puncture. Fill hole 1/8-inch above surface of unbroken Section body skin. Apply silicone compound to any cracks leading to or from puncture (2).

2-62. MAJOR SECTION BODY SKIN (TEMPORARY) (CONT)

NOTE

For effective sealing, each piece of duct tape should extend at least 1-1/2 inches beyond silicone compound edge.

5. Apply duct tape to puncture (2). Smooth tape and wipe away excess silicone compound.
6. Refer equipment to direct support/general support maintenance as soon as possible for permanent Section body skin repair.

2-63 . REPAIR INCLINOMETER ASSEMBLY

Inclinometer assembly is repaired by replacing: a. Vial b. Seal
c. Cover

VIAL**INITIAL SETUP****Tools**

Light machine repair tool kit (appendix B, section III, item 11)
Flat-tip screwdriver
Pliers
Level

Materials/Parts

Vial, inclinometer, 54-0179

2-63. REPAIR INCLINOMETER ASSEMBLY (CONT)

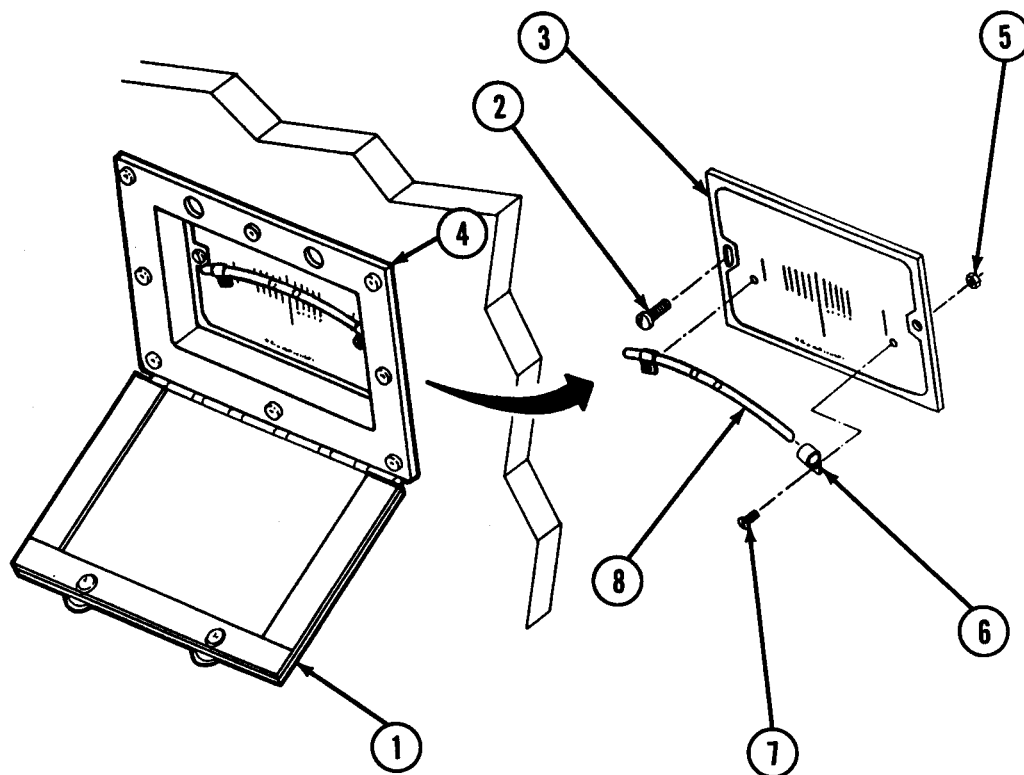

1. Open inclinometer cover (1).
2. Remove screws (2) holding inclinometer plate (3) to pan (4).
3. Remove hex nuts (5), P-clip (6), and screws (7) holding vial (8) to inclinometer plate (3).
4. Install P-clip (6) to new vial (8). Install screws (7) and hex nuts (5) to inclinometer plate (3).
5. Install inclinometer plate (3) to pan (4) with screws (2). Do not tighten.

2-63. REPAIR INCLINOMETER ASSEMBLY (CONT)CAUTION

All four corners of Section must be level. When leveling Section with one or more inoperative inclinometers, use an independent level on inside Section floor in each corner not having an accurate inclinometer. Failure to observe this caution may result in equipment damage.

NOTE

An extra person is required inside Section to observe level on Section floor while person outside raises or lowers leveling jacks.

6. Adjust leveling jacks until level inside Section indicates that Section is level. Adjust inclinometer plate (3) to pan (4) until vial (8) indicates level. Tighten screws (2).
7. Close inclinometer cover (1)

SEALINITIAL SETUPTools

Scraping knife (appendix B, section III, item 9)

Materials/Parts

Seal, 54-0180-3
 Adhesive (appendix C, item 1)
 Rubber cement thinner (appendix C, item 33)
 Rag (appendix C, item 24)

2-63. REPAIR INCLINOMETER ASSEMBLY (CONT)

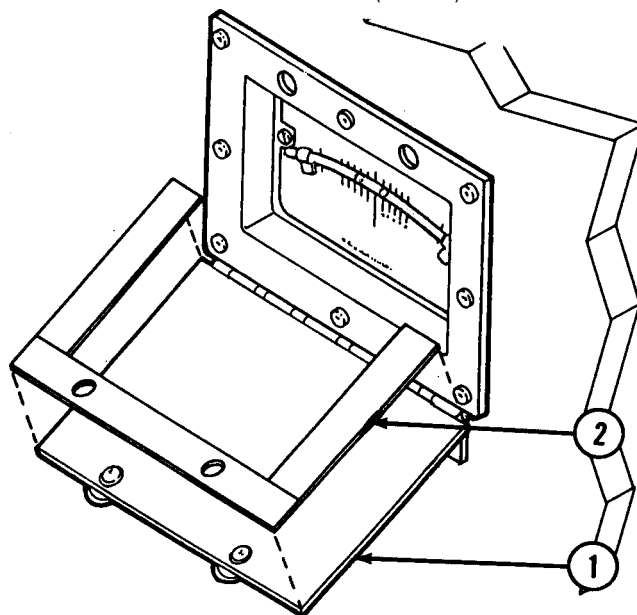

1. Open inclinometer cover (1).
2. Scrape seal (2) from inclinometer cover (1)

WARNING

CHEMICAL HAZARD. Use rubber cement thinner in a well-ventilated area. Failure to do so may result in damage to respiratory system. Wear gloves and goggles to prevent injuries to skin and eyes.

3. Using rubber cement thinner, clean adhesive residue from inclinometer cover (1).
4. Apply adhesive to inclinometer cover (1) and place new seal (2) on inclinometer cover (1).
5. Close inclinometer cover (1).

COVER

INITIAL SETUP

Tools

- Light machine repair tool kit (appendix B, section III, item 11)
- Flat-tip screwdriver
- Portable electric drill
- Twist drill set
- Rivet gun (appendix B, section III, item 10)
- Scraping knife (appendix B, section III, item 9)

2-63. REPAIR INCLINOMETER ASSEMBLY (CONT)

Materials/Parts

Cover assembly, 54-0180
 Blind rivet, 766110603 (4 required)
 Gasket, 54-0180-3
 Silicone compound (appendix C, item 7)
 Rubber cement thinner (appendix C, item 33)

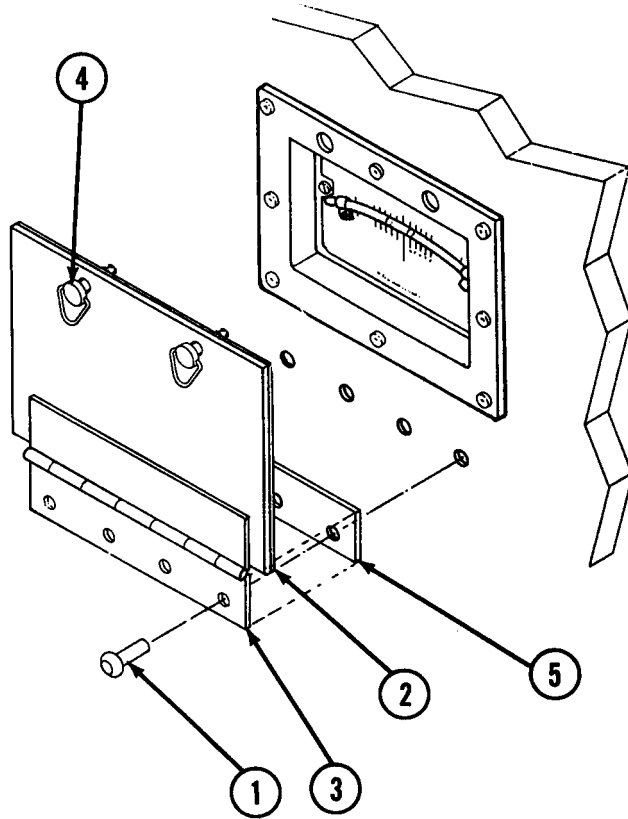

1. Remove rivets (1) securing inclinometer cover assembly (2) at hinge (3).
2. Unlatch bailhead fasteners (4) and remove inclinometer cover assembly (2) from Section body.
3. Scrape gasket (5) from Section body.

2-43. REPAIR INCLINOMETER ASSEMBLY (CONT)

WARNING

CHEMICAL HAZARD. Use rubber cement thinner in a well-ventilated area. Failure to do so may result in damage to respiratory system. Wear gloves and goggles to prevent injuries to skin and eyes.

4. Using rubber cement thinner, clean residue from Section body.

WARNING

CHEMICAL HAZARD. Use silicone compound in a well-ventilated area. Silicone compound is harmful to eyes and skin. In case of contact with eyes, immediately flush eyes with water for 15 minutes, then seek medical help. In case of contact with skin, wipe off with dry cloth, then wash with soap and water.

5. Apply silicone compound to new inclinometer cover assembly (2) at hinge (3) and place new seal (5) on inclinometer cover hinge (3).
6. Place new inclinometer cover assembly (2) on Section body. Lock in place with bailhead fastener (4) and align holes in hinge with holes in Section body.
7. Install new rivets (1) to inclinometer cover hinge (3).

2-64. ADJUST PERSONNEL/EQUIPMENT DOOR

INITIAL SETUP

Tools

Light machine repair tool kit (appendix B, section III, item 11)
Cross-tip screwdriver
Pliers
Socket wrench set
Hammer
Pin punch

2-64. ADJUST PERSONNEL/EQUIPMENT DOOR (CONT)

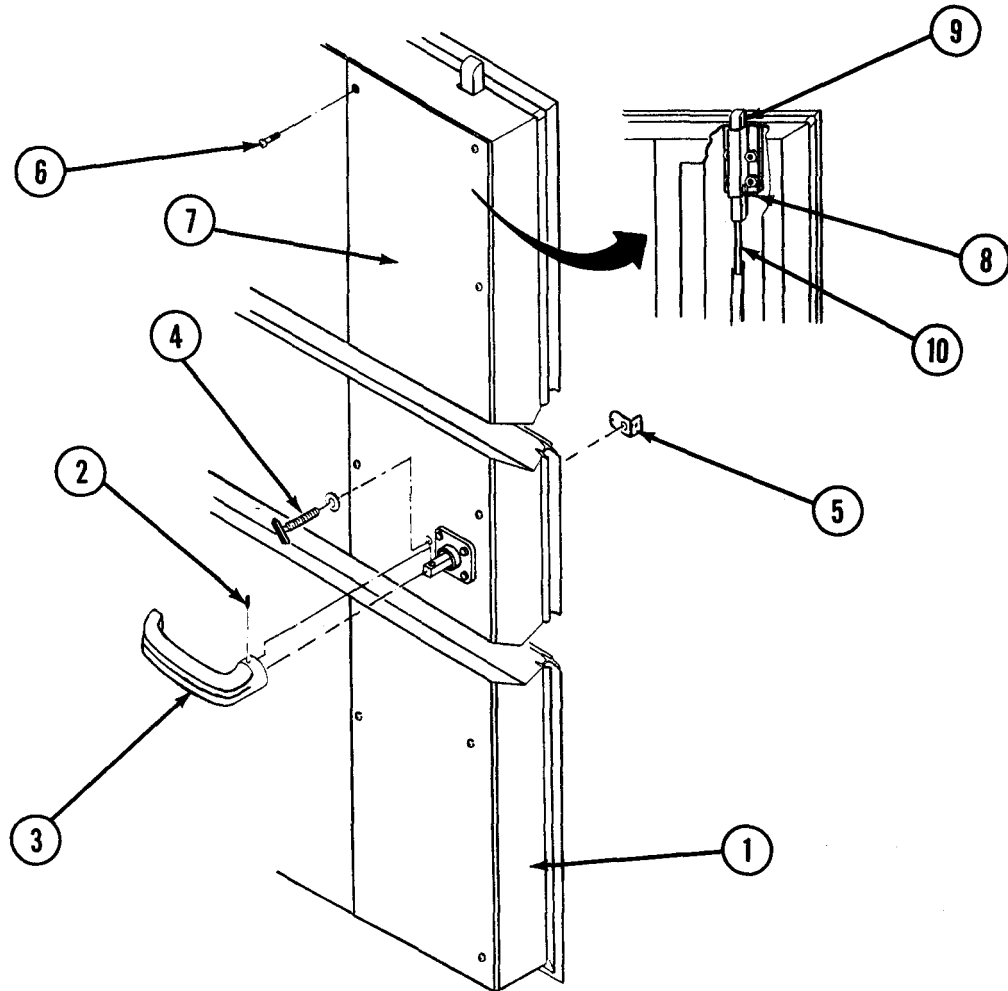

1. Open door (1).
2. Remove roll pin (2) and inner door handle (3).
3. Remove emergency escape bolt (4) and locking bracket (5).
4. Remove screws (6) securing inner door panel (7).
5. Pull back inner panel (7).
6. Loosen bolts (8) at upper and lower strikers (9). Adjust strikers (9) up or down latch arms (10) to obtain proper adjustment of strikers (9).
7. Tighten bolts (8) on upper and lower strikers (9).

2-64. ADJUST PERSONNEL/EQUIPMENT DOOR (CONT)

8. Install inner door panel (7) with screws (6).
9. Install emergency escape bolt (4) and locking bracket (5).
10. Install inner door handle (3) with roll pin (2).
11. Close door (1) and check for proper operation.

2-65. REPAIR PERSONNEL/EQUIPMENT DOOR

Personnel/Equipment doors are repaired by replacing: a. Door handle (personnel door) b. Security bolt (equipment door)

DOOR HANDLE

INITIAL SETUP

Tools

Light machine repair tool kit (appendix B, section III, item 11)
Cross-tip screwdriver
Drive pin punch
Hammer
Scraping knife (appendix B, section III, item 9)

Materials/Parts

Outer door handle assembly, 54-0205-37
Inner door handle, 9-5655
Engine lubricating oil (appendix C, item 16)
Silicone compound (appendix C, item 7)
Rubber cement thinner (appendix C, item 33)
Rag (appendix C, item 24)

2-65. REPAIR PERSONNEL/EQUIPMENT DOOR (CONT)

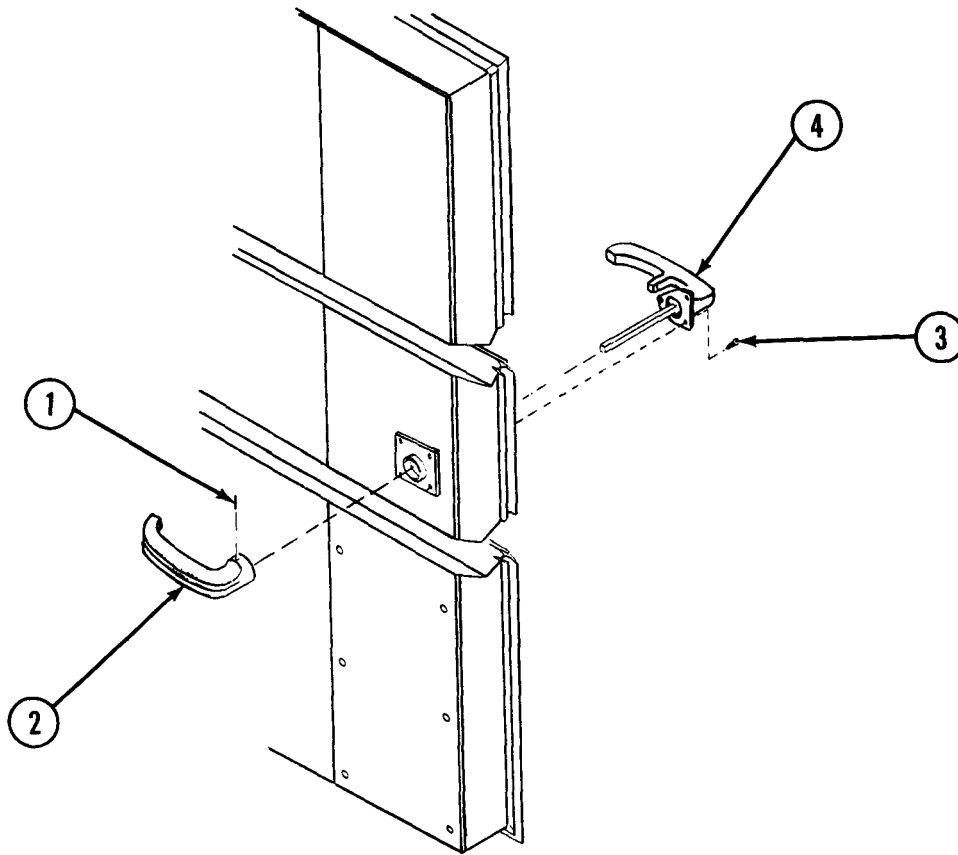

1. Open personnel door.
2. Remove roll pin (1) and inner door handle (2).
3. Remove screws (3) and outer door handle assembly (4).

WARNING

CHEMICAL HAZARD. Use rubber cement thinner in a well-ventilated area. Failure to do so may result in damage to respiratory system. Wear gloves and goggles to prevent injuries to skin and eyes.

4. Scrape adhesive off personnel door. Remove residue with rubber cement thinner and wipe dry.
5. Lubricate new outer door handle assembly (4) with a few drops of engine lubricating oil.

2-65. REPAIR PERSONNEL/EQUIPMENT DOOR (CONT)

WARNING

CHEMICAL HAZARD. Use silicone compound in a well-ventilated area. Silicone compound is harmful to eyes and skin. In case of contact with eyes, immediately flush eyes with water for 15 minutes, then seek medical help. In case of contact with skin, wipe off with dry cloth, then wash with soap and water.

6. Apply silicone compound to new outer door handle assembly (4). Install outer door handle assembly (4) with screws (3).
7. Install new inner door handle (2) with roll pin (1).
8. Close personnel door and ensure strikers engage properly.

SECURITY BOLT

INITIAL SETUP

Tools

Light machine repair tool kit (appendix B, section III, item 11)
Cross-tip screwdriver
Socket head screw key set

Materials/Parts

Security bolt, 895

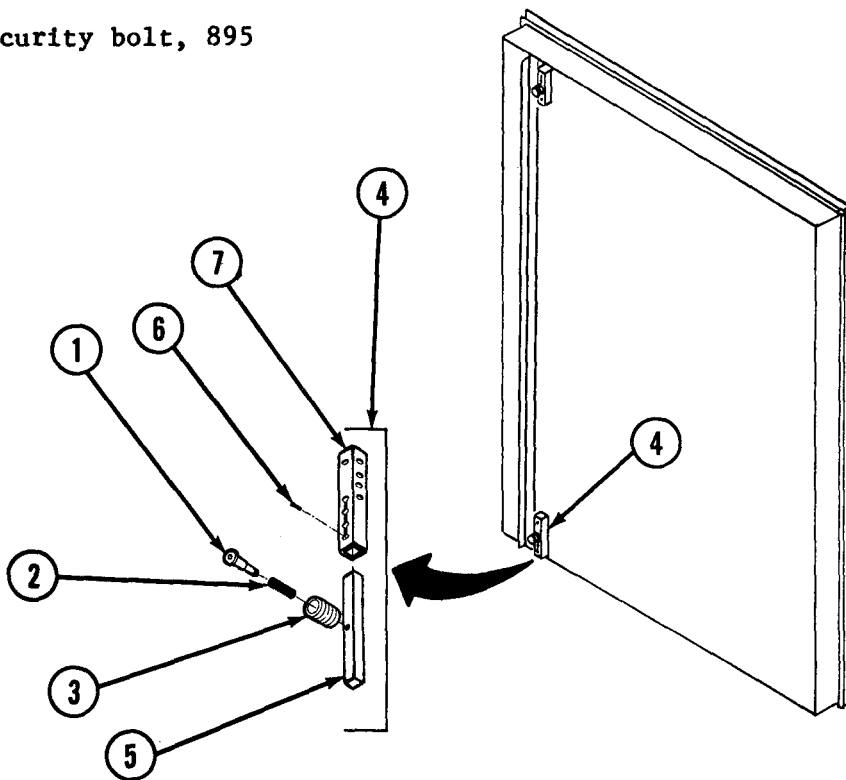

2-65. REPAIR PERSONNEL/EQUIPMENT DOOR (CONT)

1. At equipment door, remove screw (1), spring (2), and knob (3) from security bolt (4). Remove security bolt locking bar (5).
2. Remove screws (6) inside security bolt bracket (7). Remove security bolt bracket (7).
3. Install new security bolt bracket (7) with screws (6).
4. Slide new security bolt locking bar (5) into new security bolt bracket (7).
5. Install new knob (3), new spring (2), and new screw (1).
6. To test operate, close and latch security bolt. Ensure proper alignment and seal of equipment door.

2-66. REPLACE WINCH ASSEMBLY

This task covers: a. Removal b. Installation

INITIAL SETUPTools

Light machine repair tool kit (appendix B, section III, item 11)
Socket wrench set
Flat-tip screwdriver

Materials/Parts

Winch assembly, 54-0207

2-66. REPLACE WINCH ASSEMBLY (CONT)

REMOVAL

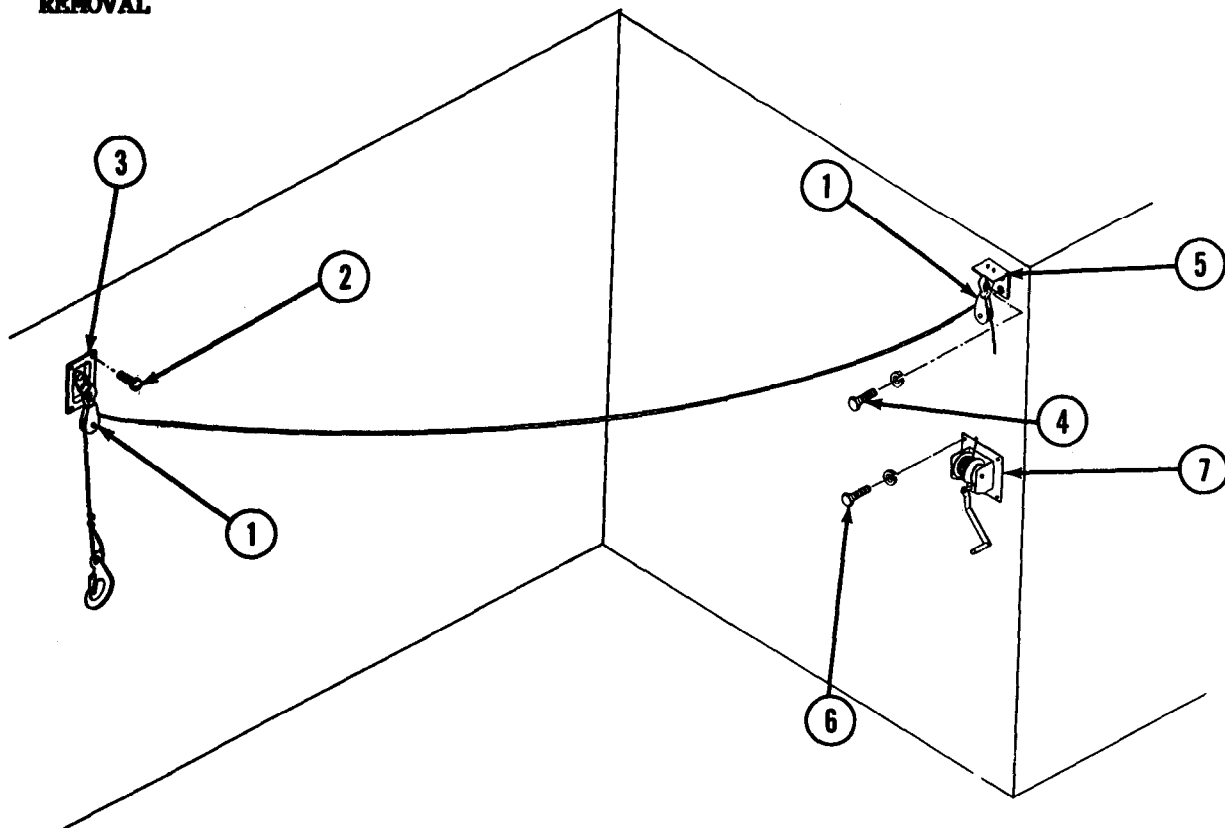

1. Remove both swivel blocks (1).
2. Remove screws (2) and recessed lifting ring (3).
3. Remove hex bolt (4), lockwashers, and angle mounting block (5).
4. Remove hex bolts (6), lockwashers, and winch mounting plate (7).

INSTALLATION

NOTE

It may be necessary to assemble winch assembly (para 2-67) before installation.

1. Install winch mounting plate (7), hex bolts (6), and lockwashers.
2. Install angle mounting block (5), hex bolts (4), and lockwashers.
3. Install recessed lifting ring (3) with screws (2).

2-66. REPLACE WINCH ASSEMBLY (CONT)

4. Install both swivel blocks (1).

WARNING

Stay clear as folding floors are raised or lowered. Weight of floors may cause serious injury.

5. Test operate by raising and lowering folding floor.

2-67. REPAIR WINCH ASSEMBLY

Winch assembly is repaired by replacing: a. Handwinch b. Keeper hook

HANDWINCH

INITIAL SETUP

Tools

- Light machine repair tool kit (appendix B, section III, item 11)
- Combination wrench set
- Socket wrench set
- Pliers

Materials/Parts

- Handwinch, 54-0135

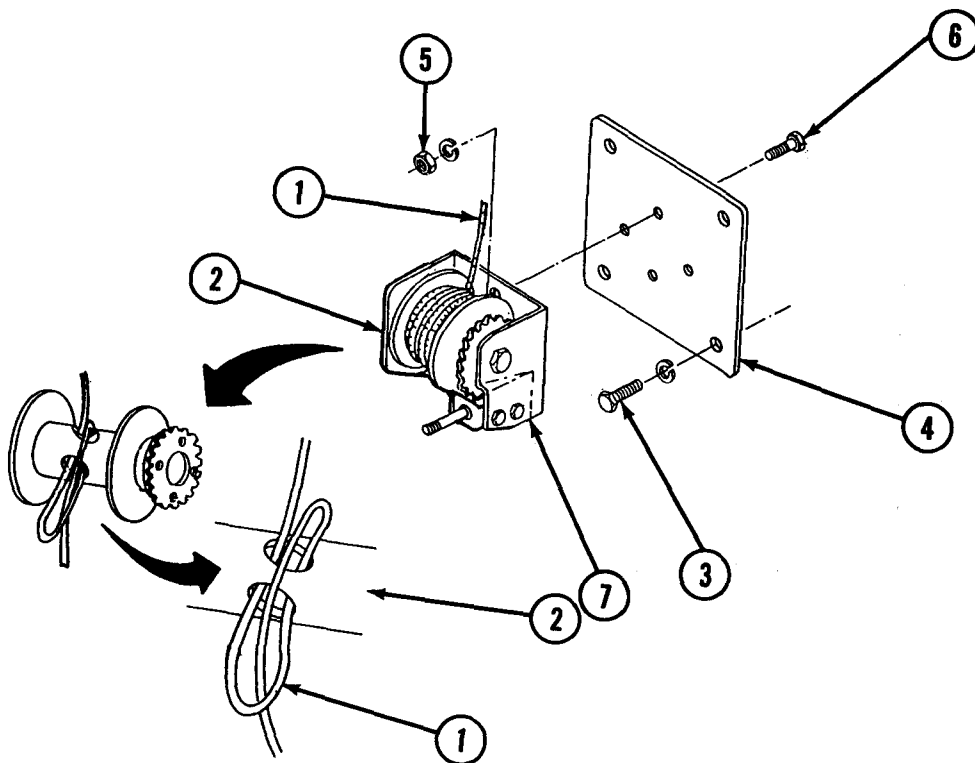

2-67. REPAIR WINCH ASSEMBLY (CONT)

1. Remove cable (1) from reel (2).
2. Remove hex bolts (3), lockwashers, and handwinch mounting plate (4).
3. Remove nuts (5), lockwashers, hex bolts (6), and handwinch (7).
4. Install new handwinch (7) on handwinch mounting plate (4) with hex bolts (6), lockwashers, and nuts (5).
5. Install handwinch mounting plate (4) with hex bolts (3) and lockwashers.
6. Install cable (1) on reel (2) as illustrated.

WARNING

Stay clear as folding floors are raised or lowered. Weight of floors may cause serious injury.

7. Test operate by raising and lowering folding floor.

KEEPER HOOK

INITIAL SETUP

Tools

Light machine repair tool kit (appendix B, section III, item 11)
Socket wrench set
Knife
Blow dryer

Materials/Parts

Keeper hook, FDA-3356-M5
Wire rope thimble, G-411
Shrink tubing, M23053/5-108-2 (6 inches required)

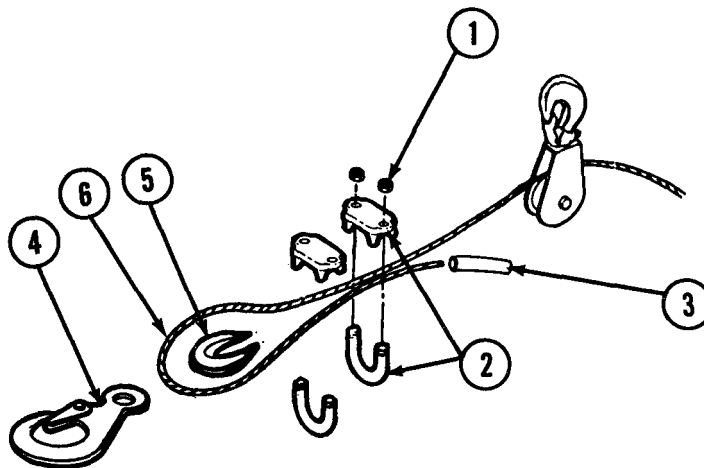

2-67. REPAIR WINCH ASSEMBLY (CONT)

1. Remove nuts (1) and cable clamps (2).
2. Cut shrink tubing (3) and remove.
3. Remove keeper hook (4) and wire rope thimble (5).
4. Thread cable (6) through new shrink tubing (3).

WARNING

Cable clamps must be installed exactly as illustrated. Clamp saddle must be on end of cable coming off reel. If saddle is installed on return end of cable, cable may slip and cause serious injury.

5. Install new wire rope thimble (5), new keeper hook (4), cable clamps (2), and nuts (1).
6. Slide shrink tubing (3) over loose end of cable (6) until cable end is 1/2-inch from shrink tubing end.
7. Shrink the shrink tubing (3) by applying hot air directly to tubing.

WARNING

Stay clear as folding floors are raised or lowered. Weight of floors may cause serious injury.

8. Test operate by raising and lowering folding floor.

2-68. REPAIR HANDWINCH

Handwinch is repaired by replacing: a. Handle b. Worm gear assembly
c. Ring gear and reel

HANDLE**INITIAL SETUP****Tools**

Light machine repair tool kit (appendix B, section III, item 11)
Socket wrench set

Materials/Parts

Handle, 0854-11

2-68. REPAIR HANDWINCH (CONT)

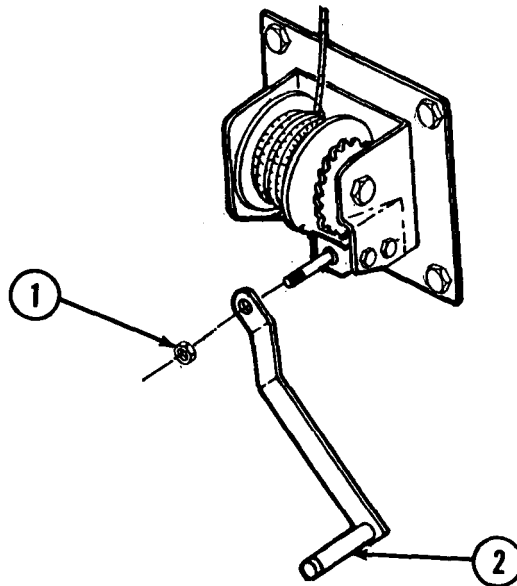

1. Remove nut (1) and handle (2).
2. Install handle (2) with nut (1).

WARNING

Stay clear as folding floors are raised or lowered. Weight of floors may cause serious injury.

3. Test operate by raising and lowering folding floor.

WORM GEAR ASSEMBLY

INITIAL SETUP

Tools

Light machine repair tool kit (appendix B, section III, item 11)
Socket wrench set

Materials/Parts

Worm gear assembly, 0764-11

2-68. REPAIR HANDWINCH (CONT)

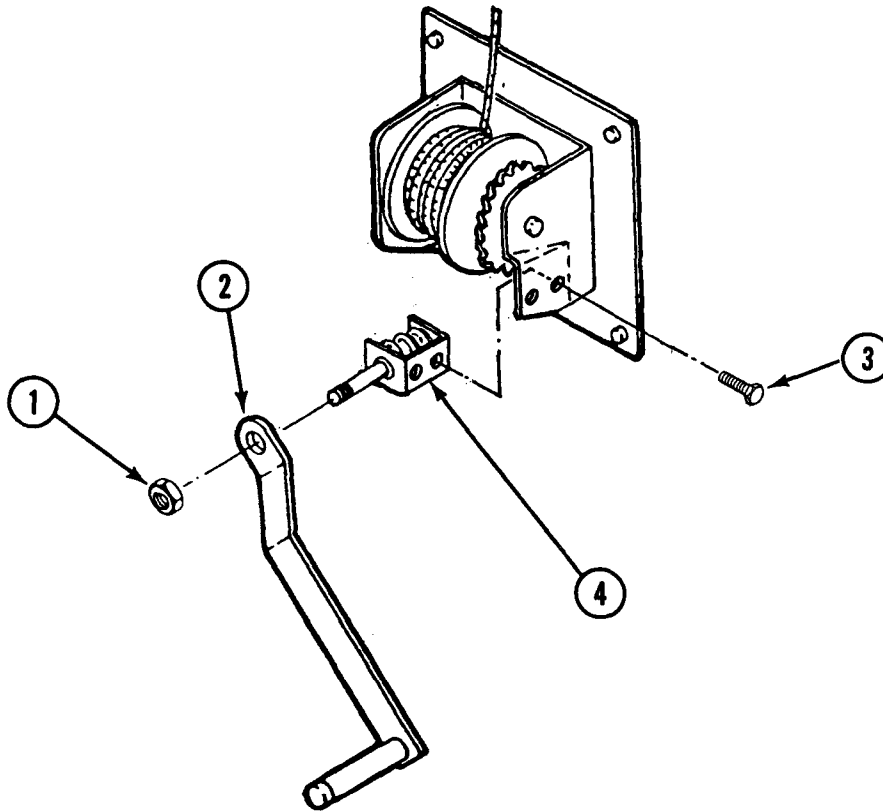
WARNING

Cable must not be under load during the following procedure. Attempting replacement of worm gear while cable is supporting folding floor may result in floor falling and cause serious personal injury.

1. Remove nut (1) and handle (2)
2. Remove hex bolts (3) and worm gear assembly (4).
3. Install new worm gear assembly (4) with hex bolts (3).
4. Install handle (2) with nut (1).

WARNING

Stay clear as folding floors are raised or lowered. Weight of floors may cause serious injury.

5. Test operate by raising and lowering folding floor.

2-68. REPAIR HANDWINCH (CONT)

RING GEAR AND REEL

INITIAL SETUP

Tools

- Light machine repair tool kit (appendix B, section III, item 11)
- Combination wrench set
- Socket wrench set
- Pliers

Materials/Parts

- Ring gear, 0765-09
- Reel subassembly, 0770-07
- Bushing, 2652-09 (2 required)

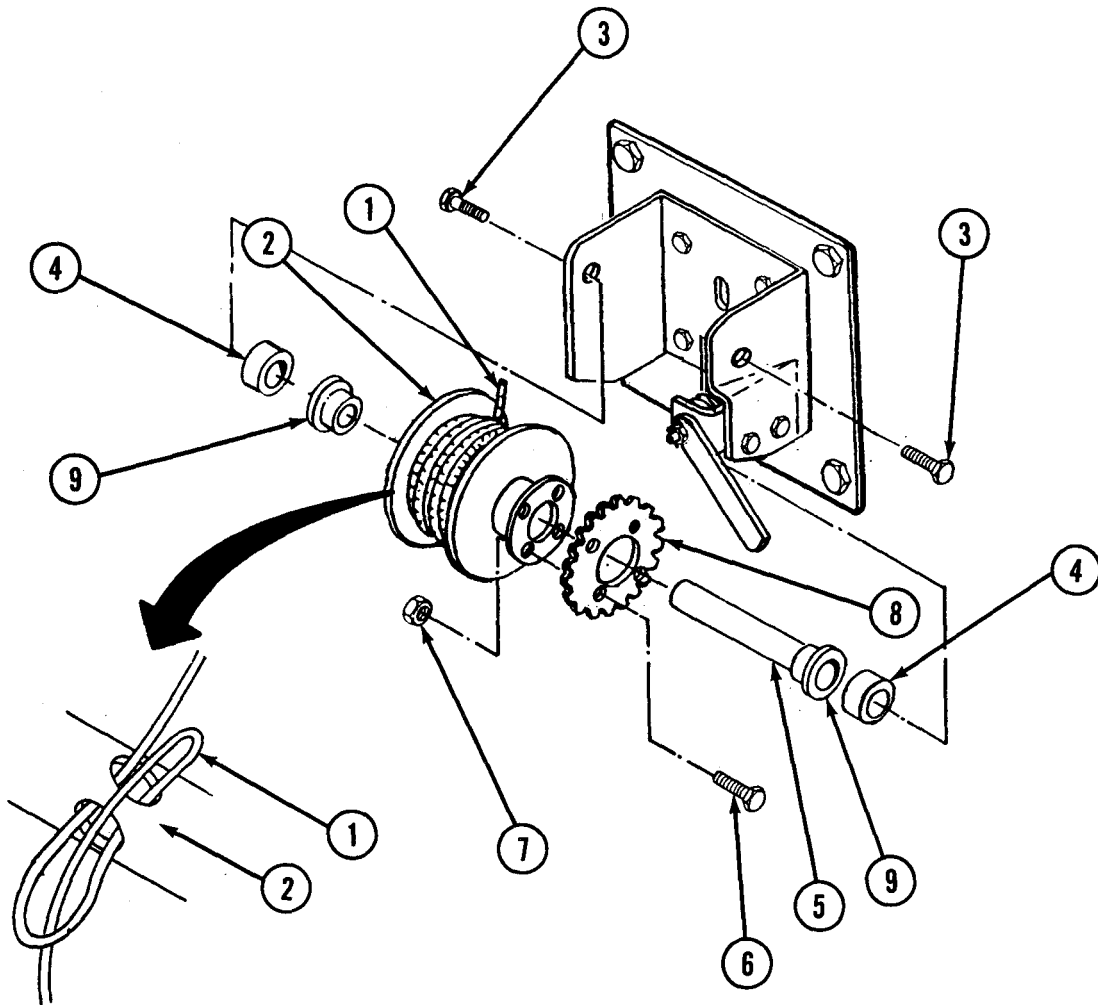

2-68. REPAIR HANDWINCH (CONT)**WARNING**

- Cable must not be under load during the following procedure. Attempting replacement of ring gear and reel while cable is supporting folding floor may cause floor to fall and cause serious personal injury.
- Use care when handling end of cable. Frayed cable ends are sharp and could puncture skin.

1. Remove cable (1) from reel (2).
2. Remove hex bolts (3), spacers/washers (4), reel (2), and shaft (5).
3. Remove hex bolts (6) and nuts (7). Separate ring gear (8) from reel (2).
4. Install new bushing (9) in new ring gear (8) on side opposite pins.
5. Install new bushing (9) in new reel (2) on side opposite ring gear (8).
6. Align pins in ring gear (8) with holes on reel (2). Secure ring gear (8) to reel (2) with hex bolts (6) and nuts (7).
7. Install shaft (5) and spacers/washers (4) in reel (2).
8. Install reel (2) in handwinch frame and secure with hex bolts (3).
9. Install cable (1) on reel (2) as illustrated.

WARNING

Stay clear as folding floors are raised or lowered. Weight of floors may cause serious injury.

10. Test operate by raising and lowering folding floor.

CHAPTER 3

DIRECT SUPPORT AND

GENERAL SUPPORT MAINTENANCE

Section I. REPAIR PARTS; SPECIAL TOOLS; TEST, MEASUREMENT, AND DIAGNOSTIC EQUIPMENT (TMDE); AND SUPPORT EQUIPMENT

3-1. COMMON TOOLS AND EQUIPMENT. For authorized common tools and equipment, refer to the Modified Table of Organization and Equipment (MTOE) applicable to your unit.

3-2. SPECIAL TOOLS, TMDE, AND SUPPORT EQUIPMENT. For repair of the Section at direct support and general support maintenance, refer to the repair parts and special tools list (RPSTL), TM 5-3610-287-24P, and the Maintenance Allocation Chart (MAC), appendix B of this manual.

3-3. REPAIR PARTS. Repair parts are listed and illustrated in the repair parts and special tools list (RPSTL), TM 5-3610-287-24P, covering direct support and general support maintenance for this equipment.

Section II. SERVICE UPON RECEIPT

3-4. SITE REQUIREMENTS. The Section should be located on firm, level ground.

3-5. SERVICE UPON RECEIPT OF MATERIEL. Refer to table 2-1 of this manual for those inspections to be made upon receipt of the Section.

3-6. CHECKING UNPACKED EQUIPMENT

a. Inspect the Section for damage incurred during shipment. If the equipment has been damaged, report the damage on SF Form 364, Report of Discrepancy (ROD).

b. Check the equipment against the packing slip to see if the shipment is complete. Report all discrepancies in accordance with the instructions of DA PAM 738-750.

c. Check to see whether the equipment has been modified.

3-7. PRELIMINARY SERVICE. Check lubrication of Section components as outlined in the lubrication order LO 5-3610-287-12.

**Section III. DIRECT SUPPORT AND GENERAL
SUPPORT PREVENTIVE MAINTENANCE CHECKS AND SERVICES (PMCS)**

3-8. GENERAL . There is no PMCS at the direct support and general support levels. Refer to table 2-2 for organizational level PMCS.

Section IV. DIRECT SUPPORT AND GENERAL SUPPORT TROUBLESHOOTING

3-9. GENERAL. This section contains the checks and corrective actions for the direct support/general support technician to troubleshoot the Section and its components. The table lists common malfunctions you may find during operation or maintenance of the Section. The tests/inspections and corrective actions should be performed in the order listed.

This manual cannot list all malfunctions, tests/inspections, or corrective actions. If a malfunction is not listed or is not corrected by the listed corrective actions, notify your supervisor.

Table 3-1. Direct Support and General Support Troubleshooting

MALFUNCTION

TEST OR INSPECTION

CORRECTIVE ACTION

BINDING FELT WHEN SIDE IS EXPANDED OR DOES NOT OPEN OR CLOSE EVENLY.

Count teeth on upper and lower gear racks on both ends of expanding side.

If teeth count of upper and lower gear racks on one end is not equal, adjust lower gear racks (para 3-18).
If teeth count on one end does not equal teeth count on other end, adjust gear rack timing (para 3-18).
If binding still occurs, adjust roller bearing and upper spur gear (para 3-18).

Section V. DIRECT SUPPORT AND GENERAL SUPPORT MAINTENANCE PROCEDURES

3-10. GENERAL . This section contains direct support and general support maintenance procedures as authorized by the Maintenance Allocation Chart (MAC), appendix B of this manual. The following topics are included as applicable: a. Installation b. Removal c. Repair. All maintenance procedures in this section will be performed by one Photolithographer (Reproduction Equipment Repairer) MOS 83F20J6. When additional personnel are required for a procedure, the MOS is shown in the initial setup.

3-10. GENERAL (CONT)

	Para		Para
Replace Air Conditioner/ Heaters	3-11	Repair Personnel/Equipment Door	3-16
Replace Air Conditioner/Heater Mounting Bracket	3-12	Repair Expanding Side Assembly	3-17
Repair Section Body Skin (Permanent)	3-13	Align Expanding Side Gear Mechanism	3-18
Replace Door Hinges	3-14	Repair Expanding Side Gear Mechanism	3-19
Replace Personnel/Equipment Door	3-15		

3-11. REPLACE AIR CONDITIONER/HEATERS

This task covers: a. Removal b. Installation

INITIAL SETUP

Tools

- Master mechanic's tool kit (appendix B, section III, item 18)
- Cross-tip screwdriver
- Combination wrench set
- Socket wrench set
- Scraping knife (appendix B, section III, item 9)

Materials/Parts

- Air conditioner, 13216E6120
- Spray foam insulation (appendix C, item 12)
- Silicone compound (appendix C, item 7)

Personnel Required

Utilities Equipment Repairer 52C10

Equipment Conditions

Emergency light set removed (para 2-20)

3-11. REPLACE AIR CONDITIONER/HEATERS (CONT)

REMOVAL

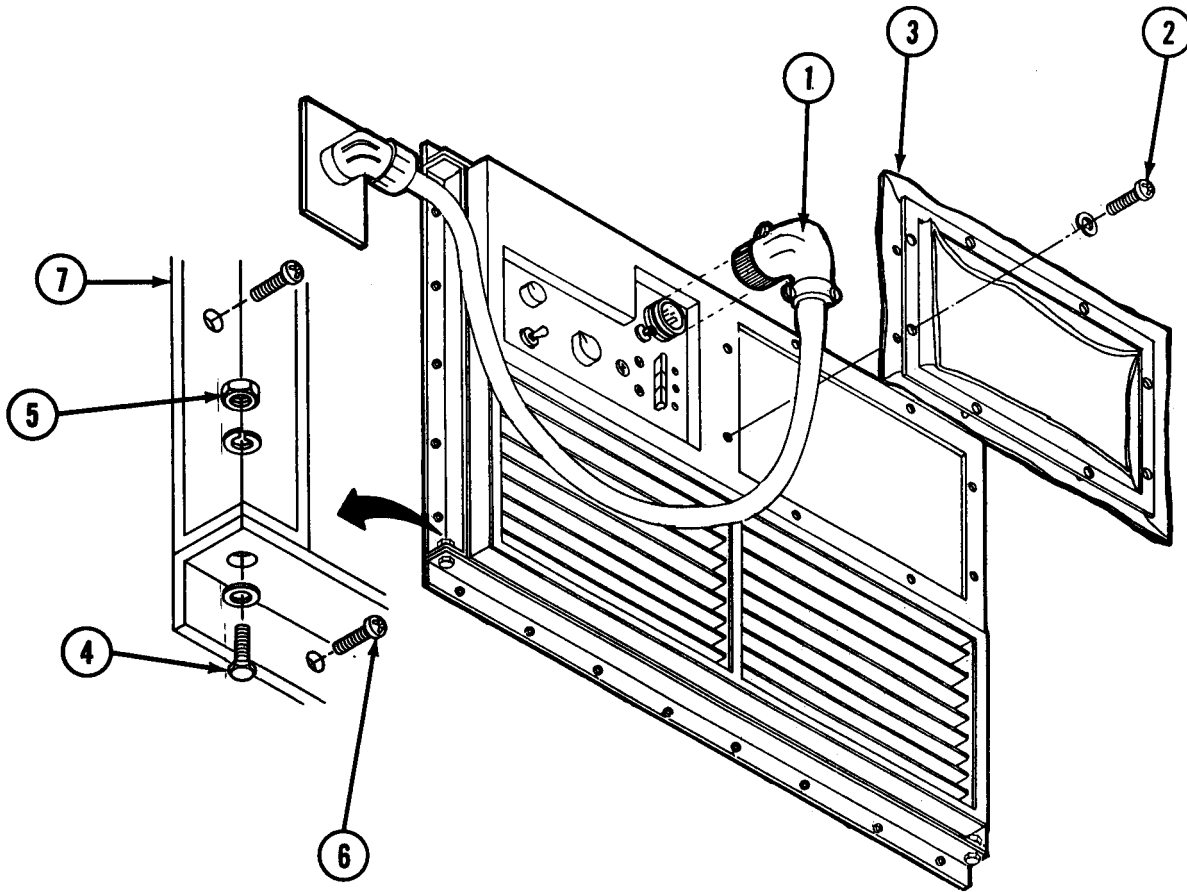

WARNING

ELECTRICAL HAZARD. Turn off both air conditioner circuit breakers before performing this procedure. Failure to observe this warning may result in death or serious injury.

NOTE

Heavy lifting device is required for the following procedure.

1. Set both AIR CONDITIONER circuit breakers to OFF.
2. Disconnect power cable (1) at air conditioner/heater.
3. Remove screws (2), lockwashers, and bellows (3).
4. Remove hex bolts (4), flatwashers, lockwashers, and nuts (5).

3-11. REPLACE AIR CONDITIONER/HEATER (CONT)

5. Remove screws (6) and bezels (7).
6. Remove spray foam insulation.

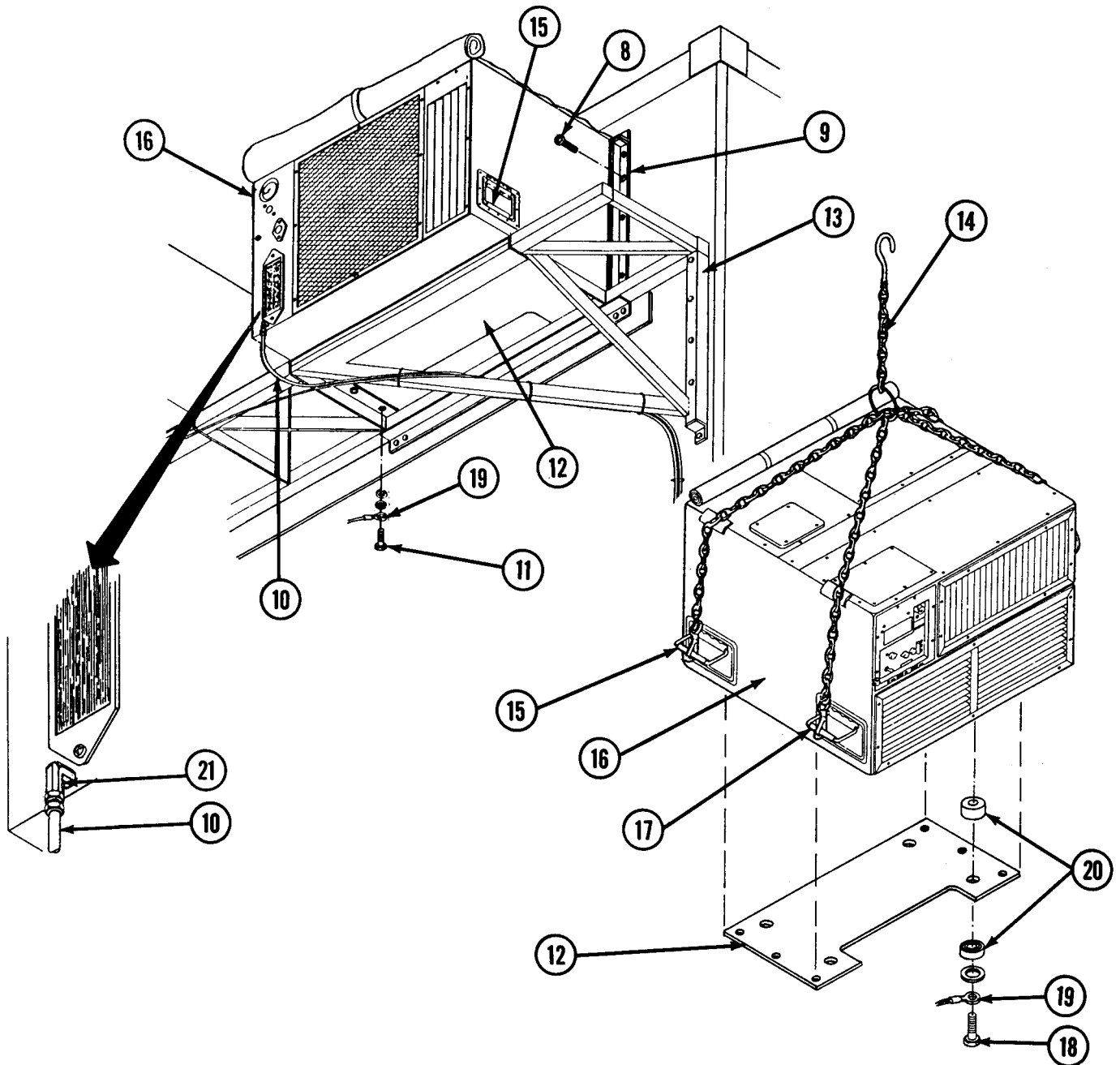

7. Remove screws (8) and exterior bezels (9).
8. Disconnect drain tube (10).

3-11. REPLACE AIR CONDITIONER/HEATERS (CONT)

9. Remove hex bolts (11), lockwashers, and flatwashers securing air conditioner/heater mounting plate (12) to mounting bracket (13).
10. Position heavy lifting device next to Section.
11. Connect sling (14) to hoist and rear lifting handles (15).
12. Push air conditioner/heater (16) with mounting plate (12) out of Section until front lifting handles (17) are exposed.
13. Attach sling (14) to front lifting handles (17).

WARNING

HEAVY EQUIPMENT. The air conditioner weighs 256 lbs (116 kg). Use proper lifting device and stay clear of air conditioner when lifting. Maintenance personnel must be visible to hoist operator and in position to guide air conditioner away from Section. Failure to observe this warning may result in death or serious injury.

14. Lift air conditioner/heater (16) with mounting plate (12) from mounting bracket (13) and lower to transport vehicle or ground.
15. Remove hex bolts (18), ground wire (19), flatwashers, resilient mounts (20), and mounting plate (12) from air conditioner/heater (16).
16. Remove copper fitting (21).
17. Remove sling (14).

INSTALLATION

1. Attach sling (14) to new air conditioner/heater (16).
2. Install copper fitting (21).
3. Install mounting plate (12) with hex bolts (18), ground wire (19), flatwashers, and resilient mounts (20).

3-11. REPLACE AIR CONDITIONER/HEATERS (CONT)**WARNING**

HEAVY EQUIPMENT. The air conditioner weighs 256 lbs (116 kg). Use proper lifting device and stay clear of air conditioner when lifting. Maintenance personnel must be visible to hoist operator and in position to guide air conditioner away from Section. Failure to observe this warning may result in death or serious injury.

4. Lift air conditioner/heater (16) with mounting plate (12) into position on mounting bracket (13).
5. Remove sling (14) from front lifting handles (17).
6. Push air conditioner/heater (16) and mounting plate (12) into Section.
7. Secure mounting plate (12) to mounting bracket (13) with hex bolts (11), ground wire (19), lockwashers, and flatwashers.
8. Remove sling (14) from rear lifting handles (15).
9. Install drain tube (10).
10. Install bezels (9) with screws (8).

WARNING

CHEMICAL HAZARD. Use silicone compound in a well-ventilated area. Silicone compound is harmful to eyes and skin. In case of contact with eyes, immediately flush eyes with water for 15 minutes, then seek medical help. In case of contact with skin, wipe off with dry cloth, then wash with soap and water.

11. Apply silicone compound to seams between air conditioner/heater (16) and exterior bezels (9).
12. Inside Section, install spray foam insulation.
13. Install bezels (7) with screws (6).
14. Install hex bolts (4), flatwashers, lockwashers, and nuts (5).
15. Install bellows (3) with screws (2) and lockwashers.
16. Connect power cable (1) to air conditioner/heater.

3-11. REPLACE AIR CONDITIONER/HEATERS (CONT)

17. Set both AIR CONDITIONER circuit breakers to ON.
18. Test operate air conditioner/ heaters for cooling and heating.

3-12. REPLACE AIR CONDITIONER/HEATER MOUNTING BRACKET

This task covers: a. Removal b. Installation

INITIAL SETUP

Tools

- Master mechanic's tool kit (appendix B, section III, item 18)
 - Socket wrench set
 - Pry bar
- Knife (appendix B, section III, item 16)
- Scraping knife (appendix B, section III, item 9)
- Pliers (appendix B, section III, item 15)

Materials/Parts

- Air conditioner mounting bracket, 13225E3057
- Tiedown strap, MIL-S-23190D, type 1, class I (4 required)
- Neoprene washer, 13226E7955 (10 required)
- Silicone compound (appendix C, item 7)
- Rubber cement thinner (appendix C, item 33)
- Paint (appendix C, items 18, 19, 20)
- Aliphatic thinner (appendix C, item 32)
- Spray kit (appendix C, item 26)

Equipment Conditions

- Air conditioner/ heaters and mounting plates removed (para 3-11)

3-12. REPLACE AIR CONDITIONER/HEATER MOUNTING BRACKET (CONT)

REMOVAL

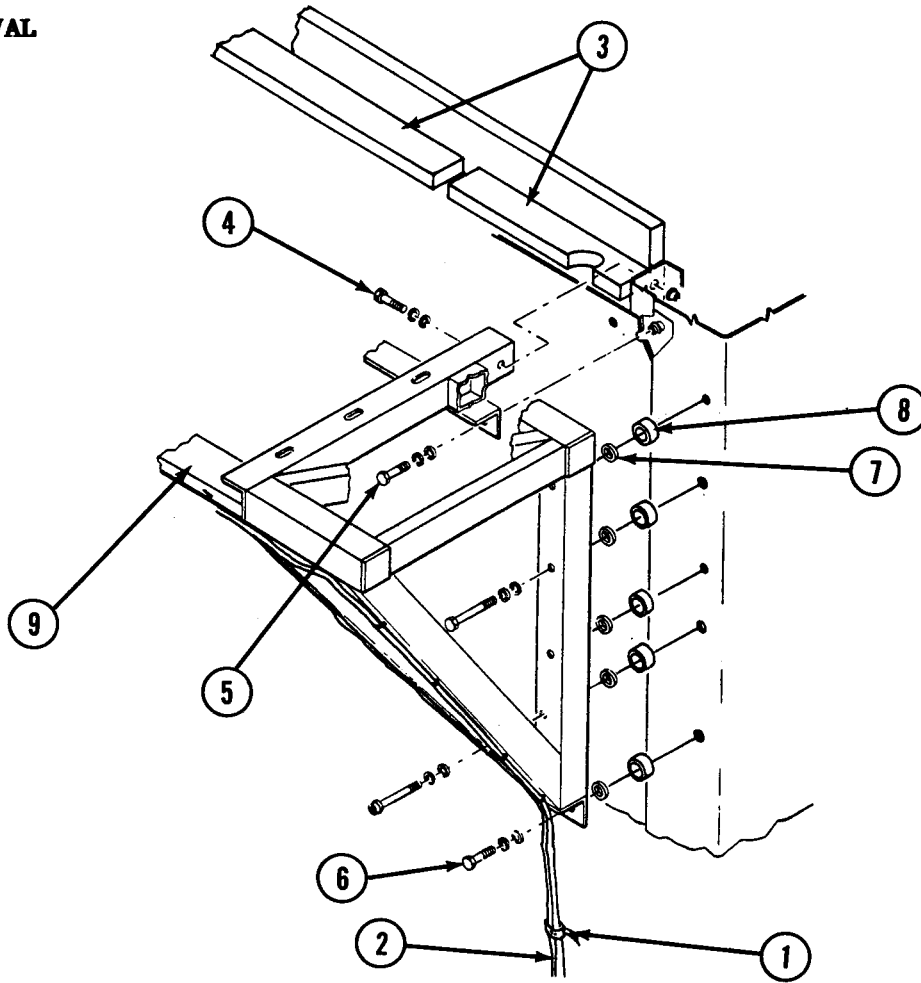

NOTE

Heavy lifting device is required for the following procedures.

1. Remove tiedown straps (1) and drain tube (2).
2. Position lifting device and connect sling to air conditioner/heater mounting bracket.

NOTE

Spacers removed in the following step are imbedded in silicone compound and must be broken free with scraping knife and pry bar.

3. Remove four wood spacers (3).

3-12. REPLACE AIR CONDITIONER/HEATER MOUNTING BRACKET (CONT)

4. Remove four hex bolts (4), lockwashers, and flatwashers.
5. Remove eight hex bolts (5), lockwashers, and flatwashers.
6. Remove 10 hex bolts (6), lockwashers, flatwashers, neoprene washers (7), and spacers (8).

WARNING

Use proper lifting device and stay clear of mounting bracket when lifting. Maintenance personnel must be visible to hoist operator and in position to guide mounting bracket away from Section. Failure to observe this warning may result in death or serious injury.

7. Lower mounting bracket (9) onto transport vehicle or ground and remove.

WARNING

CHEMICAL HAZARD. Use rubber cement thinner in a well-ventilated area. , Failure to do so may result in damage to respiratory system. Wear gloves and goggles to prevent injuries to skin and eyes.

8. Scrape silicone compound from spacers (8), wood spacers (3), and Section body. Remove residue with rubber cement thinner.

INSTALLATION

WARNING

Use proper lifting device and stay clear of mounting bracket when lifting. Maintenance personnel must be visible to hoist operator and in position to guide mounting bracket away from Section. Failure to observe this warning may result in death or serious injury.

1. Install sling on new air conditioner/heater mounting bracket (9) and lift into position.

3-12. REPLACE AIR CONDITIONER/HEATER MOUNTING BRACKET (CONT)WARNING

CHEMICAL HAZARD. Use silicone compound in a well-ventilated area. Silicone compound is harmful to eyes and skin. In case of contact with eyes, immediately flush eyes with water for 15 minutes, then seek medical help. In case of contact with skin, wipe off with dry cloth, then wash with soap and water.

2. Apply silicone compound to back of spacers (8).
3. Install spacers (8), neoprene washers (7), hex bolts (6), lockwashers, and flatwashers.
4. Install hex bolts (5), lockwashers, and flatwashers.
5. Install hex bolts (4), lockwashers, and flatwashers.
6. Apply silicone compound to wood spacers (3) and area where spacers will be installed.
7. Install wood spacers (3) and fill gaps with silicone compound to form tight seal between Section body and spacers (3).
8. Install drain tubes (2) with tiedown straps (1).
9. Paint in accordance with TM 43-0139.

3-13. REPAIR SECTION BODY SKIN (PERMANENT)INITIAL SETUPTools

Light machine repair tool kit (appendix B, section III, item 11)
 Portable electric drill
 Twist drill set
 Rivet gun (appendix B, section III, item 10)

Materials/Parts

Sheet metal, 3003-H 14
 Rivets, 766110603
 Silicone compound (appendix C, item 7)
 Rag (appendix C, item 24)
 Lead pencil (appendix C, item 13)
 Spray kit (appendix C, item 26)
 Paint (appendix C, items 18, 19, 20)
 Aliphatic thinner (appendix C, item 32)

3-13. REPAIR SECTION BODY SKIN (PERMANENT) (CONT)

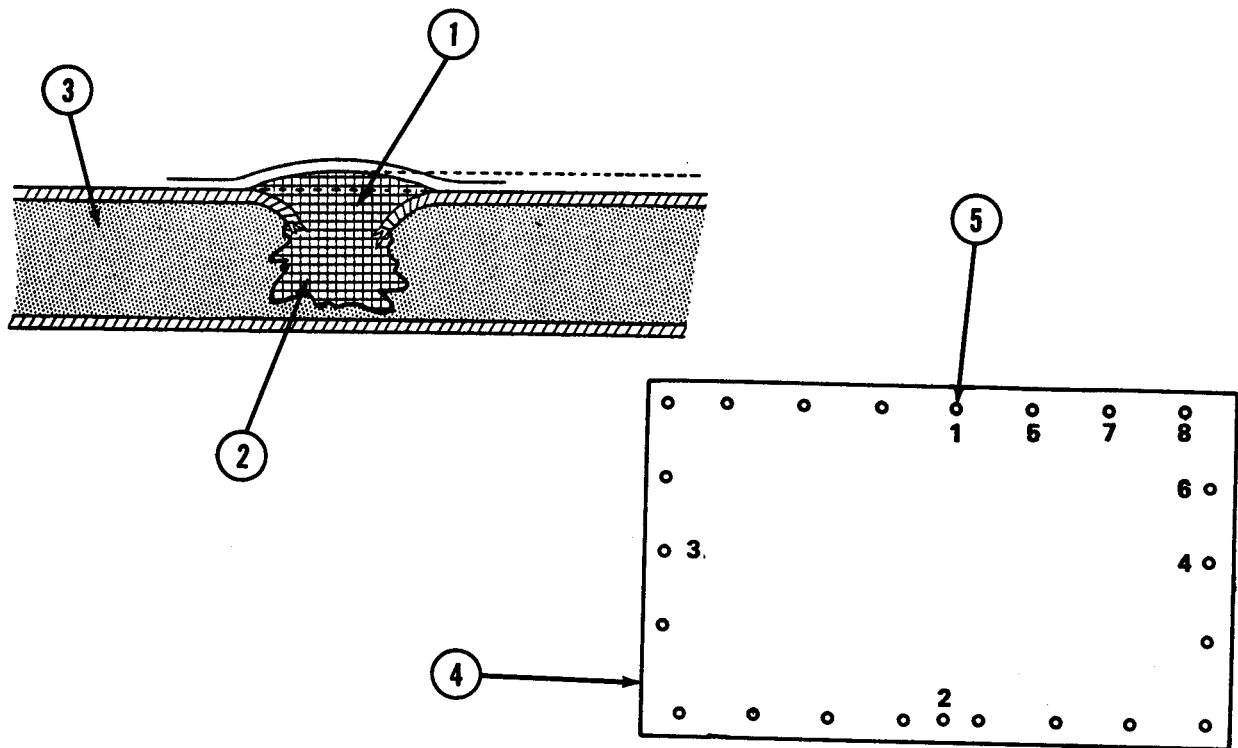

WARNING

Do not attempt to remove Section body skin fragments by pulling or cutting. Failure to observe this warning may result in serious injury or further damage to equipment.

1. Bend broken edges of skin (1) into puncture (2).
2. Remove loose fragments of foam (3).
3. Use rag and water to clean puncture area. Wipe dry.
4. Prepare sheet metal patch (4) large enough to cover damaged area.
5. Place sheet metal patch (4) over damaged area and mark around edges of patch.
6. Remove sheet metal patch from Section and drill 13/64-inch (0.52 cm) holes about 1 inch (2.54 cm) apart around edges of sheet metal patch (4).

3-13. REPAIR SECTION BODY SKIN (PERMANENT) (CONT)WARNING

CHEMICAL HAZARD. Use silicone compound in a well-ventilated area. Silicone compound is harmful to eyes and skin. In case of contact with eyes, immediately flush eyes with water for 15 minutes, then seek medical help. In case of contact with skin, wipe off with dry cloth, then wash with soap and water.

7. Apply silicone compound in puncture (2). Fill puncture to 1/8 inch (3.2 mm) above surface of unbroken skin. Apply silicone compound to cracks leading to puncture (2).
8. Apply silicone compound to edges of sheet metal patch (4) and place patch onto Section body.

NOTE

To prevent buckles in patch, holes should be drilled and rivets installed in order shown by numbers in patch illustrated above.

9. Beginning at center of each side, drill one hole through Section body and install rivets (5).
10. After middle of each side of patch has been riveted, drill remaining holes through Section body skin in order shown above and install rivets.
11. Paint sheet metal patch (4) in accordance with TM 43-0139.

3-14. REPLACE DOOR HINGES

This task covers: a. Removal b. Installation

INITIAL SETUPTools

Master mechanic's tool kit (appendix B, section III, item 18)
 Portable electric drill
 Twist drill set
 File
 Cross-tip screwdriver
 Centerpunch
 Ballpeen hammer
 Tape measure
 Sheet metal shears

3-14. REPLACE DOOR HINGES (CONT)

Materials/Parts

Door hinge, 54-0193-8
Carriage bolt, 3/8" Dia. x 2", 5306-00-406-5178 (5 required)
Flatwasher, 5310-00-889-2763 (5 required)
Lockwasher, 5310-00-637-9541 (5 required)
Hex nut, 5310-00-655-9544 (5 required)
Self-tapping screws, 5305-00-432-4172 (4 required)
Lead pencil (appendix C, item 13)
Spray kit (appendix C, item 26)
Paint (appendix C, items 18, 19, 20)
Paint (appendix C, item 20A)
Aliphatic thinner (appendix C, item 32)

REMOVAL

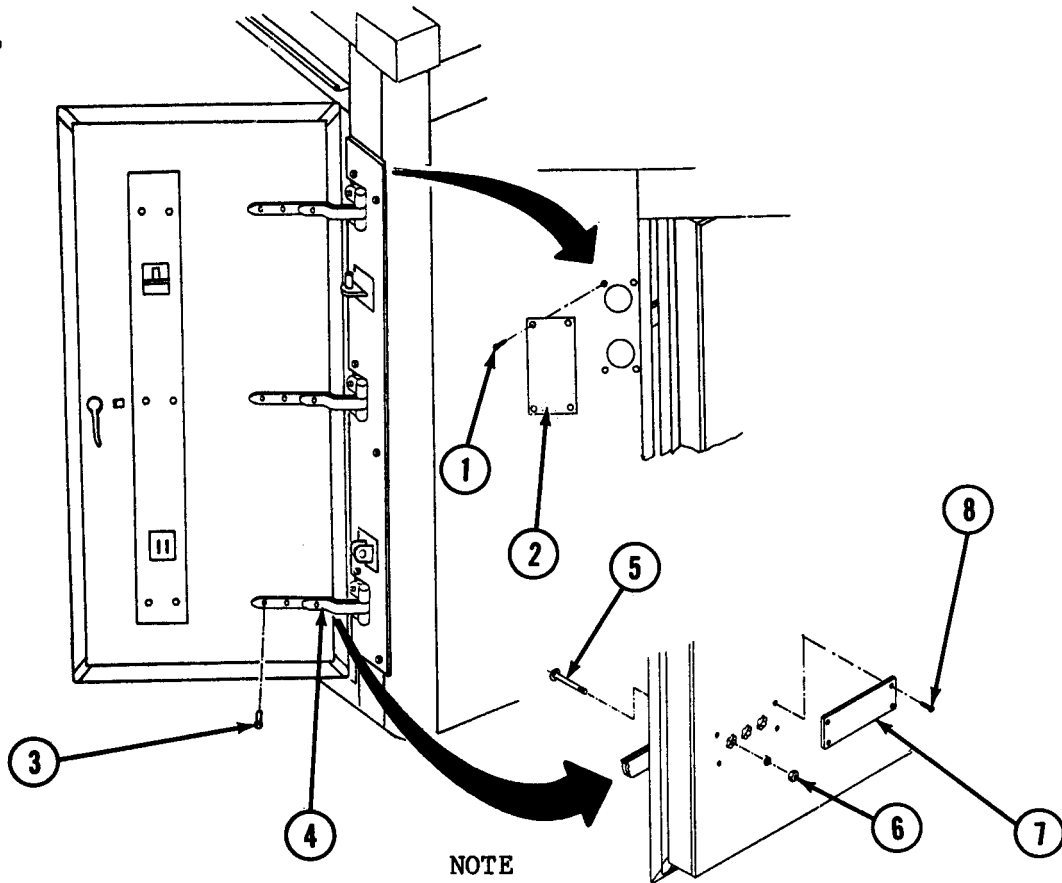

NOTE

The following step applies to equipment door only.

1. Remove modified five-drawer storage cabinet (para 2-33) and wall storage cabinet (para 2-27).
2. Remove screws (1) and cover plate (2).

3-14. REPLACE DOOR HINGES (CONT)

NOTE

- Original hinges are installed with two-piece rivets that must be drilled out for replacement. Replacement-hinges are attached with carriage bolts, lockwashers, flatwashers, and nuts.
- If more than one hinge on a door is to be replaced, replace only one hinge at a time.

3. Locate center of rivets (3) securing hinge to door.
4. On outside of door, measure from edge of door (not seal) to center of each rivet (3), and record measurements.
5. On outside of door, measure from bottom of door (not seal) to center of each rivet (3), and record measurements.
6. Mark inside of door with outside measurements.
7. Using 1/4-inch drill bit, drill a 1-inch diameter circle around each rivet center mark.
8. Break out center of circle and remove.
9. Dig out foam insulation until rivet heads are exposed.
10. Centerpunch rivet head to start drill bit.
11. Drill out rivets (3) and remove hinge (4).

INSTALLATION

1. File holes in hinge to fit head of carriage bolt (5).
2. Position hinge (4) and install carriage bolts (5), lockwashers, flatwashers, and hex nuts (6).
3. From 1/16-inch thick scrap aluminum, cut a fabricated cover plate (7) 1-3/4 inches by 7-1/2 inches. Using cover plate (2) as a template, drill four attaching holes in fabricated cover plate (7).
4. Position cover plate (2) and install screws (1).
5. Position fabricated cover plate (7) over rivet access holes in door and drill holes to accept self-tapping screws.
6. Install fabricated cover plate (7) with screws (8).

3-14. REPLACE DOOR HINGES (CONT)

7. Treat and paint new cover plate in accordance with TM 43-0139.
8. Check door for binding and alignment.
9. Lubricate new hinge as required.
10. If necessary, replace modified five-drawer storage cabinet (para 2-33) and wall storage cabinet (para 2-27).

3-15. REPLACE PERSONNEL/EQUIPMENT DOOR

This task covers: a. Removal b. Installation

INITIAL SETUP

Tools

Master mechanic's tool kit (appendix B, Section III, item 18)
Socket wrench set
Combination wrench set
Portable electric drill
Twist drill set
Ballpeen hammer
Cross-tip screwdriver
Centerpunch
Level
File
Tap set
Scraping knife (appendix B, section III, item 9)

Materials/Parts

Rear personnel door, 54-0205-1
Curbside personnel door, 54-0205-2
Equipment door, 54-0204
Carriage bolt, 5306-00-406-5178 (6 required)
Flatwasher, 5310-00-889-2763 (6 required)
Lockwasher, 5310-00-637-9541 (6 required)
Hex nut, 5310-00-655-9544 (6 required)
Silicone compound (appendix C, item 7)
Rag (appendix C, item 24)
Rubber cement thinner, (appendix C, item 33)
Paint (appendix C, items 18, 19, 20)
Aliphatic thinner (appendix C, item 32)
Spray kit (appendix C, item 26)

3-15. REPLACE PERSONNEL/EQUIPMENT DOOR (CONT)

REMOVAL

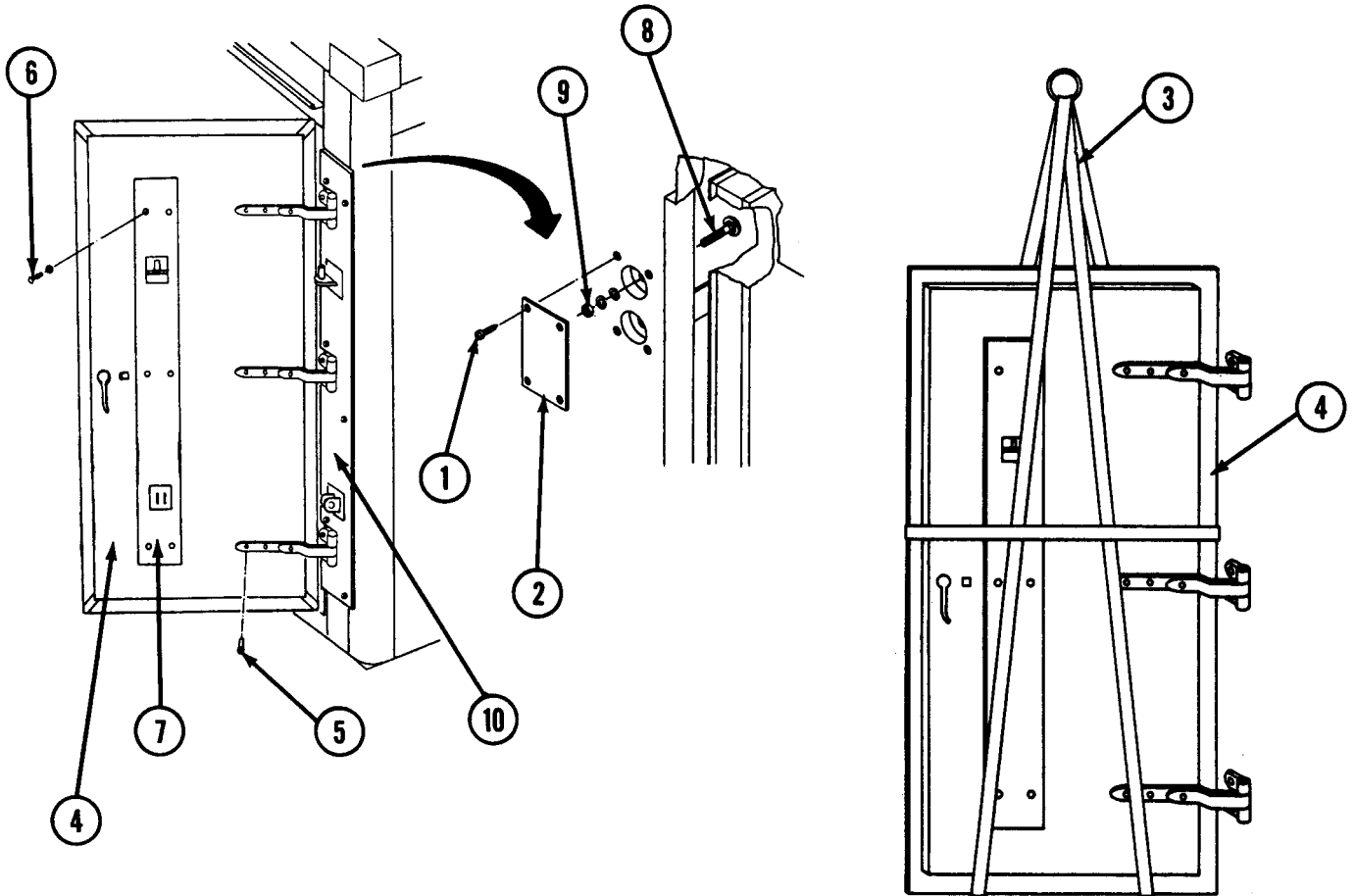

NOTE

The following step applies to equipment door only.

1. Remove modified five-drawer storage cabinet (para 2-33) and wall storage cabinet (para 2-27).
2. Remove screws (1) and cover plates (2).

3-15. REPLACE PERSONNEL/EQUIPMENT DOOR (CONT)

3. Place sling (3) on door (4) as illustrated.

NOTE

Original hinges are installed on personnel/equipment doors with two-piece rivets that must be drilled out for door replacement. Replacement doors are attached with carriage bolts, lockwashers, flatwashers, and hex nuts.

4. Centerpunch head of rivets (5).
5. Drill out rivets (5) and remove door (4).

NOTE

The following step applies to equipment door only.

6. Remove bulletin board, blackout curtain tiedowns, and strap and buckle assembly for later installation on replacement door.

NOTE

The following two steps apply to rear personnel door and equipment door only.

7. Remove bolts (6), lockwashers, and inner boarding ladder mounting bracket (7).

WARNING

CHEMICAL HAZARD. Use rubber cement thinner in a well-ventilated area. Failure to do so may result in damage to respiratory system. Wear gloves and goggles to prevent injuries to skin and eyes.

8. Scrape silicone compound from back of inner boarding ladder mounting bracket (7). Clean off residue with rubber cement thinner.

INSTALLATION

1. If necessary, file holes in hinges to fit head of carriage bolt (8).
2. Position door (4) and install carriage bolts (8), lockwashers, flatwashers, and hex nuts (9). Snug, but do not tighten.
3. Close door (4) and latch.
4. Shim under door (4) until door is positioned evenly in door frame.

3-15. REPLACE PERSONNEL/EQUIPMENT DOOR (CONT)

5. Tighten hex nuts (9) attaching hinges to Section body.
6. Test operate door (4) for proper operation. Check for binding or misalignment.
7. Position cover plates (2) and install screws (1).

NOTE

The following step applies to equipment door only.

8. Install bulletin board, blackout curtain tiedowns, and strap and buckle assembly.

NOTE

The following steps apply to rear personnel door and equipment door only.

9. Install boarding ladder on outer boarding ladder mounting bracket (10).
10. To locate and mark mounting holes, install inner boarding ladder mounting bracket (7) on mounted boarding ladder and position on door.
11. Locate and mark mounting holes for mounting bracket (7).
12. Remove boarding ladder and mounting bracket (7) from door.
13. Drill mounting holes and tap holes for bolts (6).

WARNING

CHEMICAL HAZARD. Use silicone compound in a well-ventilated area. Silicone compound is harmful to eyes and skin. In case of contact with eyes, immediately flush eyes with water for 15 minutes, then seek medical help. In case of contact with skin, wipe off with dry cloth, then wash with soap and water.

14. Apply silicone compound to back of inner boarding ladder mounting bracket (7) and install on door with bolts (6) and lockwashers.
15. Install boarding ladder on mounting brackets. Adjust mounting brackets on boarding ladder as necessary.
16. Remove boarding ladder from mounting brackets (7) and install for operation.

3-15. REPLACE PERSONNEL/EQUIPMENT DOOR (CONT)

NOTE

The following step applies to rear personnel door only.

17. Using level on interior Section floor, level Section if necessary.
18. Open rear personnel door inclinometer cover and adjust vial if necessary.
19. Paint in accordance with TM 43-0139.

3-16. REPAIR PERSONNEL/EQUIPMENT DOOR

Personnel/Equipment doors are repaired by replacing: Seals

SEALS

INITIAL SETUP

Tools

Master mechanic's tool kit (appendix B, section III, item 18)
Pliers
Flat-tip screwdriver
Hammer
Shears
Folding Ladder

Materials/Parts

Dual durometer seal, 54-0205-20 (Equipment door)
Dual durometer seal, 54-0205-1-20 (Rear personnel door)
Dual durometer seal, 54-0205-2-20 (Curbside personnel door)
Corner tab seal, 54-0204-10 (8 required for each door)
Corner reinforcement seal, 54-0204-10 (4 required for each door)
Rag (appendix C, item 24)
Rubber cement thinner (appendix C, item 33)
Adhesive (appendix C, item 1)

3-16. REPAIR PERSONNEL/EQUIPMENT DOOR (CONT)

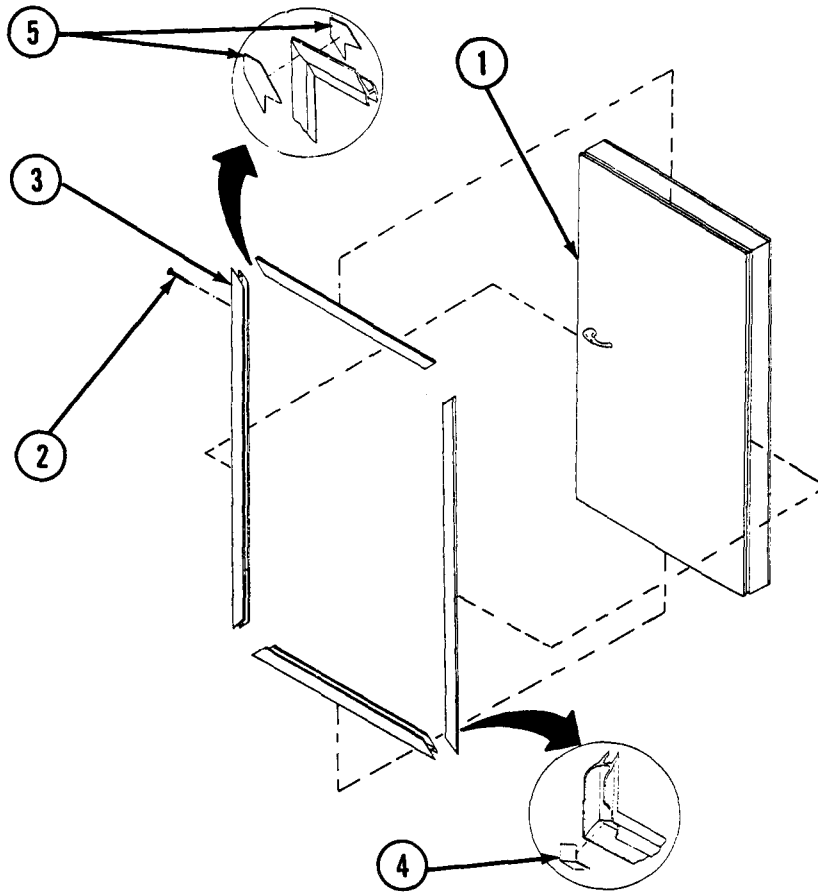

1. Open and secure door (1).
2. Remove screw nails (2) from seal (3).
3. Remove corner reinforcement seals (4) from seals (3) at each corner of door (1).
4. Remove corner tab seals (5).
5. Remove seals (3) from door (1) and scrape remaining pieces of seal (3) and adhesive.

WARNING

CHEMICAL HAZARD. Use rubber cement thinner in a well-ventilated area. Failure to do so may result in damage to respiratory system. Wear gloves and goggles to prevent injuries to skin and eyes.

6. Remove remaining adhesive with rubber cement thinner. Wipe surface dry.

3-16. REPAIR PERSONNEL/EQUIPMENT DOOR (CONT)

WARNING

CHEMICAL HAZARD. Use adhesive in a well-ventilated area. Adhesive is harmful to eyes and skin. In case of contact with eyes, immediately flush eyes with water for 15 minutes, then seek medical help. In case of contact with skin, wipe off with dry cloth, then wash with soap and water.

7. Apply adhesive to area where new seal (3) is to be placed.
8. Press new seal (3) onto door (1). Wipe off excess adhesive.
9. Install screw nails (2) to new seal (3).
10. Apply adhesive to area inside and outside where new corner tab seals (5) are to be placed. Press corner tab seals (5) into place. Wipe off excess adhesive.
11. Apply adhesive to area where new corner reinforcement seals (4) are to be placed. Press new corner reinforcement seals (4) into place. Wipe off excess adhesive.

NOTE

The following step applies to equipment door only.

12. On curbside edge of equipment door, cut outer flap of seal flush with door.
13. Close door (1) and check for proper seal.

3-17. REPAIR EXPANDING SIDE ASSEMBLY

Expanding side assembly is repaired by replacing: a. Wiper seal
b. Rubber strip seal c. Seal

WIPER SEAL

INITIAL SETUP

Tools

Master mechanic's tool kit (appendix B, section III, item 18)
Flat-tip screwdriver
Folding ladder

3-17. REPAIR EXPANDING SIDE ASSEMBLY (CONT)

Materials/Parts

Wiper seal, 54-0092-34

Equipment Conditions

Section level and expanded (TM 5-3610-287-10, para 2-6)

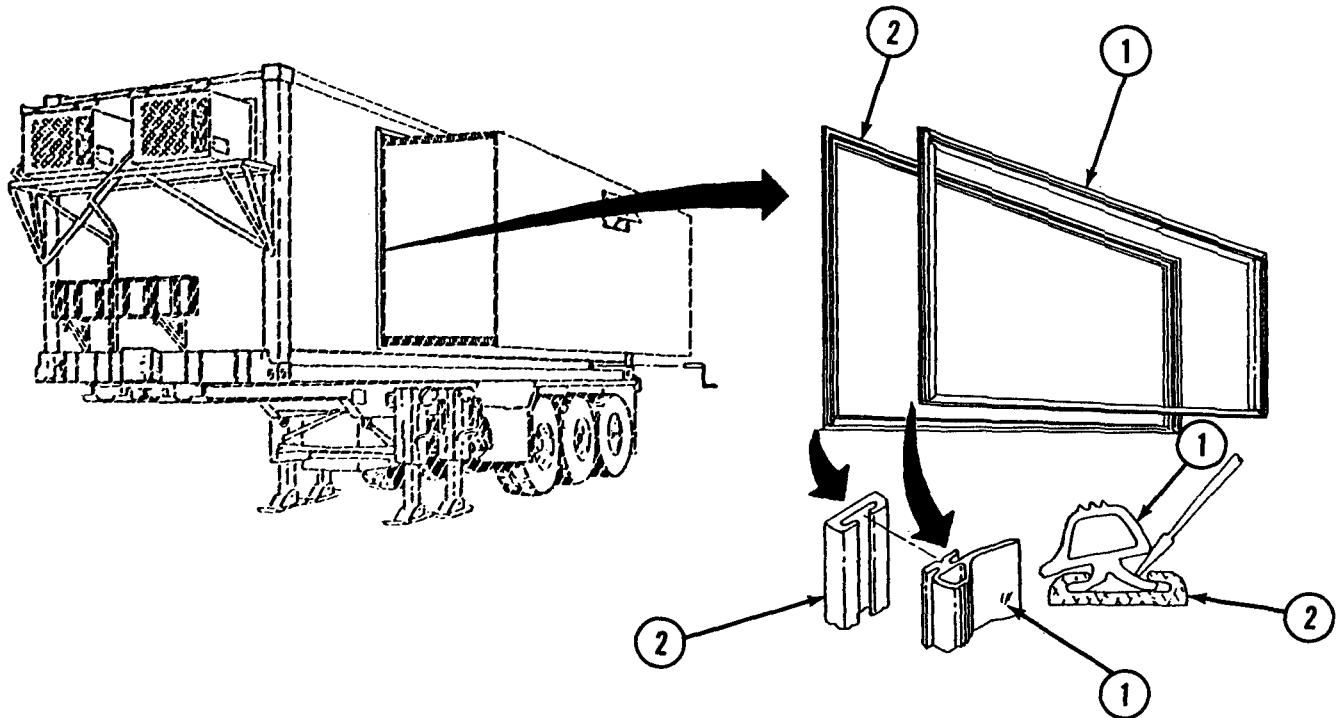

1. Starting at lower corner of wiper seal (1), remove wiper seal from track (2).

CAUTION

Do not cut excess length from wiper seal. Excess length will be drawn into track after wiper seal is inserted. Cutting wiper seal could cause expanding side to leak.

2. Place upper right and left molded corners of new wiper seal (1) in track (2).
3. Starting at center of upper horizontal track (2), install wiper seal (1), moving toward upper right and left molded corners.
4. Place lower right and left molded corners of new wiper seal (1) in track (2).

3-17. REPAIR EXPANDING SIDE ASSEMBLY (CONT)

5. Starting at center of right and left vertical tracks (2), insert wiper seal (1), moving toward upper and lower molded corners.
6. Starting at center of lower horizontal tracks (2), insert remaining wiper seal (1), moving toward lower molded corners.

RUBBER STRIP SEAL

INITIAL SETUP

Tools

- Master mechanic's tool kit (appendix B, section III, item 18)
- Flat-tip screwdriver
- Socket wrench set

Materials/Parts

- Rubber strip seal, 54-0081-32

Equipment Conditions

- Section level and expanded (TM 5-3610-287-10, para 2-6)

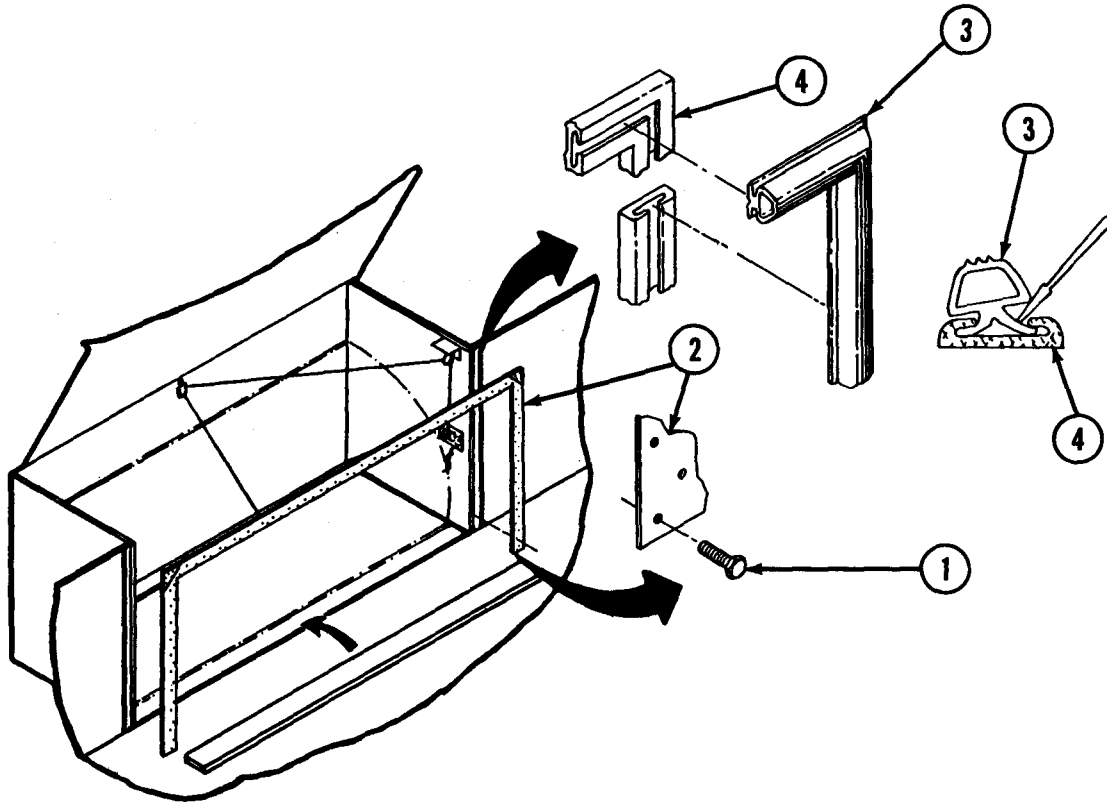

3-17. REPAIR EXPANDING SIDE ASSEMBLY (CONT)

1. Remove removable floor sections.
2. Remove hex bolts (1) and vertical and horizontal inner metal strips (2).
3. Starting at bottom end, remove rubber strip seal (3) from track (4).

CAUTION

Do not cut excess length from rubber strip seal. Excess length will be drawn into track after seal is inserted. Cutting seal may cause expanding side to leak.

4. Place upper right and left molded corners of new rubber strip seal (3) in track (4).
5. Starting at center of upper track (4), insert rubber strip seal (3), moving toward upper molded corners.
6. Starting at center of vertical tracks (4), insert rubber strip seal (3), moving toward upper molded corner and bottom of track.
7. Position metal strip (2) and install hex bolts (1).
8. Install removable floor sections.

SEALINITIAL SETUPTools

Master mechanic's tool kit (appendix B, section III, item 18)
Flat-tip screwdriver

Materials/Parts

Seal, 54-0199-53 (2 required)
Seal, 54-0195-105

Equipment Conditions

Section level and expanded (TM 5-3610-287-10, para 2-6)

3-17. REPAIR EXPANDING SIDE ASSEMBLY (CONT)

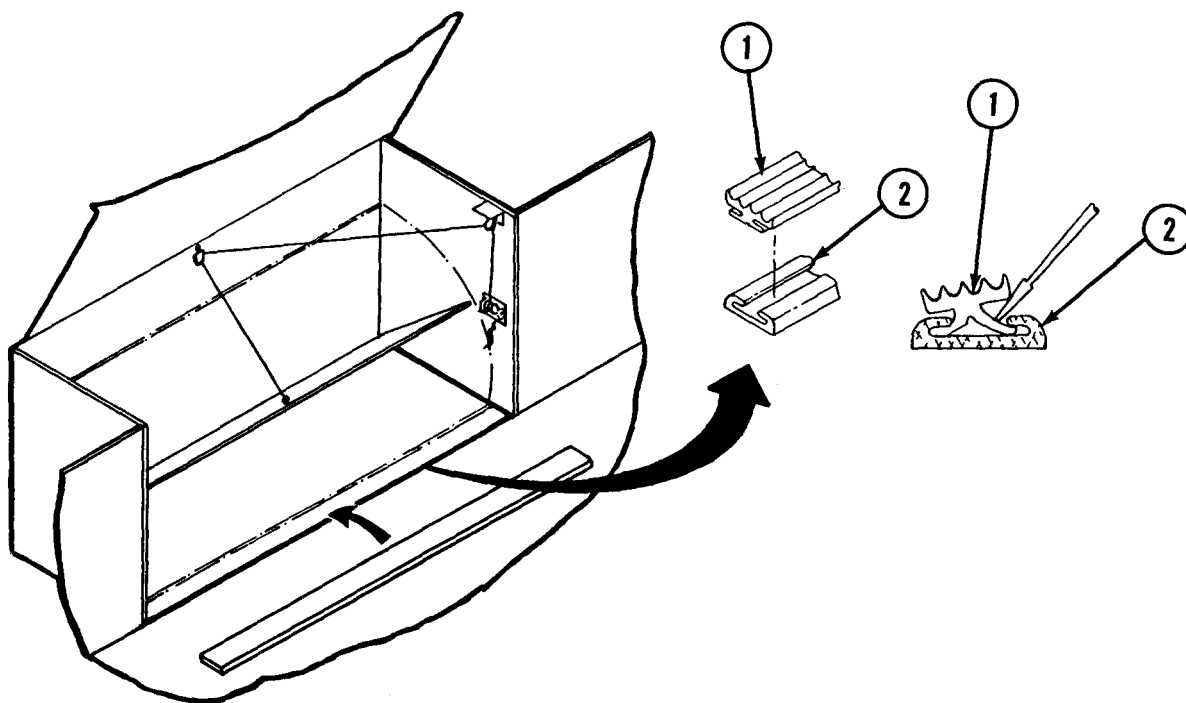

WARNING

Stay clear as folding floors are raised or lowered. Weight of floors may cause serious injury.

1. Raise folding floor and lock in up position (TM 5-3610-287-10, para 2-7).
2. Remove seal (1) from track (2).

CAUTION

Do not cut excess length from seal. Excess length will be drawn into track after seal is inserted. Cutting seal will cause improper fit.

3. Position new seal (1) on track (2) and insert base of seal into track (2).
4. Lower folding floor and lock in down position (TM 5-3610-287-10, para 2-6).

3-18. ALIGN EXPANDING SIDE GEAR MECHANISM

Expanding side gear mechanism is aligned by: a. Adjusting lower gear rack
 b. Adjusting roller bearing and upper spur gear c. Adjusting gear rack timing

ADJUSTING LOWER GEAR RACK

INITIAL SETUP

Tools

- Master mechanic's tool kit (appendix B, section III, item 18)
- Socket wrench set
- Combination wrench set
- Pry bar
- Steel rule
- Hydraulic jack (appendix B, section III, item 17)

Equipment Conditions

Section level and expanded (TM 5-3610-287-10, para 2-6)

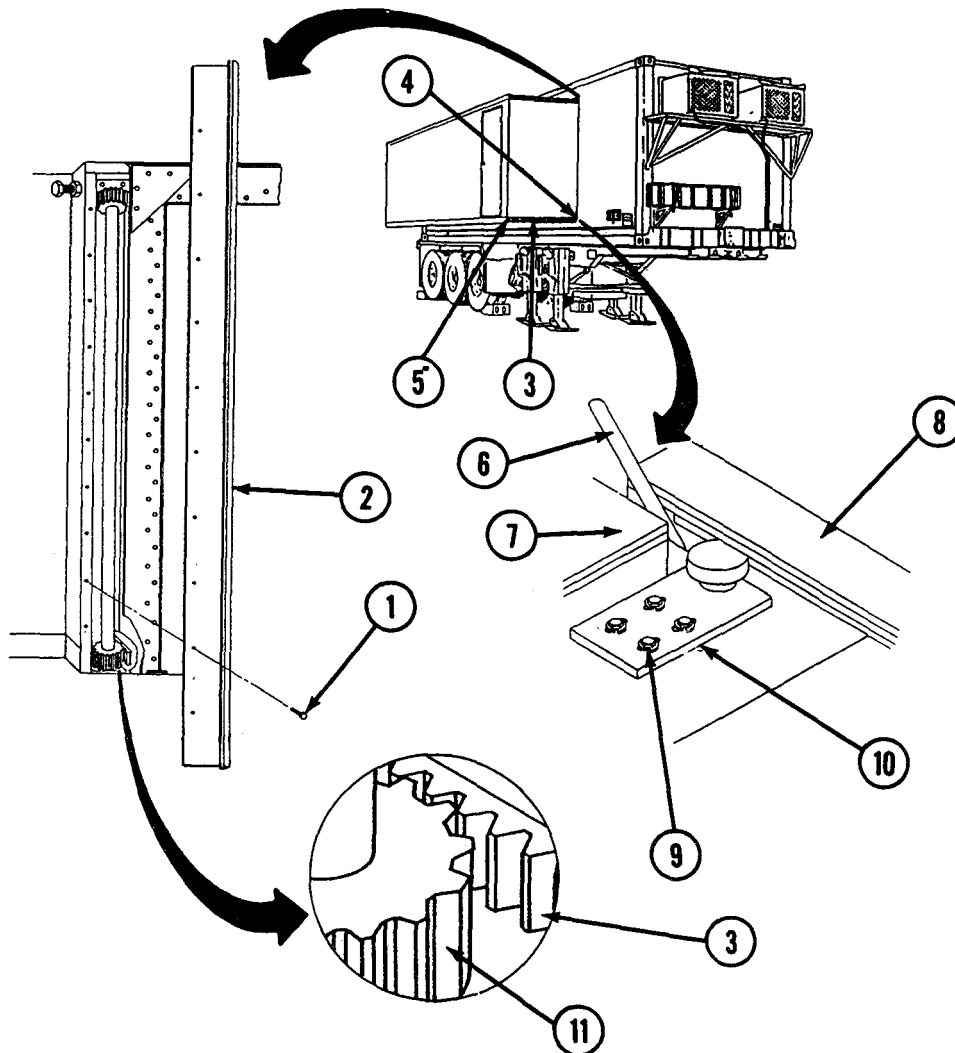

3-18. ALIGN EXPANDING SIDE GEAR MECHANISM (CONT)

WARNING

Be sure expanding side is firmly blocked before adjusting lower gear rack. Serious injury to personnel and damage to equipment can result if gear rack slips.

NOTE

This procedure is performed only when lower gear rack is out of time with upper gear rack.

1. Place hydraulic jack under outside corner of expanding side.

WARNING

Stay clear as folding floors are raised or lowered. Weight of floors may cause serious injury.

2. Unlock and raise folding floor (TM 5-3610-287-10, para 2-7).
3. Remove both removable floor sections.
4. Remove 10 screws (1) securing vertical inner seal strip (2) to Section. Move seal strip (2) aside.
5. Count number of teeth on gear rack (3) between wiper seal (4) and end of expanding side (5). There should be 49 teeth exposed.

WARNING

Keep hands well away from gear track area while holding pry bar. Serious injury to personnel could result if gear rack slips.

NOTE

An extra person is required to hold expanding side in position with pry bar while steps 6 through 12 are performed.

6. Insert pry bar (6) between Section floor (7) and expanding side (8) as illustrated. Apply pressure to hold expanding side (8) in position.
7. Loosen bolts (9) at roller assembly (10).
8. Slowly release pressure on pry bar (6) to disengage gear rack teeth (3) from spur gear (11). Remove pry bar (6).

3-18. ALIGN EXPANDING SIDE GEAR MECHANISM (CONT)

9. Adjust hydraulic jack up or down to align expanding side gear rack (3) with spur gear (11). Be sure number of teeth on gear rack (3) between wiper seal (4) and end of expanding side (5) is 49.
10. Insert pry bar (6) between Section floor (7) and expanding side (8) as illustrated.
11. Apply pressure to pry bar (6) until there is 1/16- to 1/8-inch (1-2 cm) clearance between spur gear (11) and lower gear rack (3) as illustrated.
12. Position roller assembly (10) firmly against expanding side (8) and secure bolts (9). Remove pry bar (6).
13. Ensure clearance between spur gear (11) and lower gear rack (3) remains 1/16- to 1/8-inch (1-2 cm).
14. Lower hydraulic jack and remove.

CAUTION

Before retracting expanding sides, ensure areas at both expanding side tracks are clear of obstructions. Failure to do so may result in equipment damage.

15. Retract expanding sides 4 to 6 inches (10-15 cm).
16. Position seal strip (2) and secure with screws (1).
17. Ensure rubber seal is firmly in track.
18. Extend expanding side.
19. Install removable floor section.

WARNING

Stay clear as folding floors are raised or lowered. Weight of floors may cause serious injury.

20. Lower folding floor and lock in down position (TM 5-3610-287-10, para 2-6).

3-18. ALIGN EXPANDING SIDE GEAR MECHANISM (CONT)

ADJUSTING ROLLER BEARING AND UPPER SPUR GEAR

INITIAL SETUP

Tools

Master mechanic's tool kit (appendix B, section III, item 18)

Adjustable wrench

Socket wrench set

Combination wrench set

Pry bar

Steel rule

Hydraulic jack (appendix B, section III, item 17)

Equipment Conditions

Section level and expanded (TM 5-3610-287-10, para 2-6)

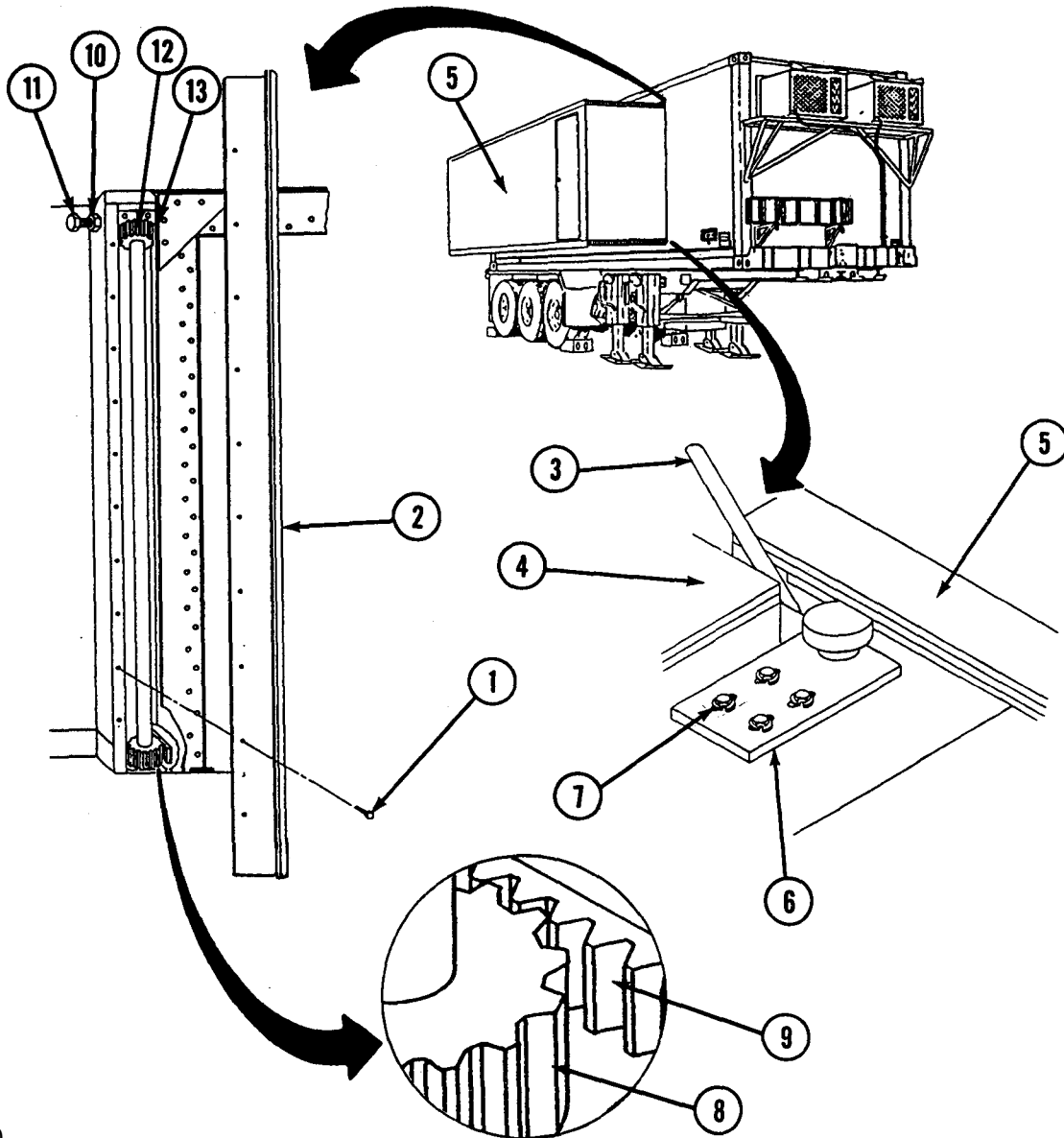

3-18. ALIGN EXPANDING SIDE GEAR MECHANISM (CONT)WARNING

Be sure expanding side is firmly blocked and keep hands away from gear track area while performing the following procedure. Serious injury to personnel and damage to equipment can result if gear track slips.

1. Place hydraulic jack under outside corner of expanding side.

WARNING

Stay clear as folding floors are raised or lowered. Weight of floors may cause serious injury.

2. Unlock and raise folding floor (TM 5-3610-287-10, para 2-7).
3. Remove both removable floor sections.
4. Remove 10 screws (1) securing seal strip (2) to Section. Move seal strip (2) aside.

NOTE

- If only the upper gear rack is being adjusted, omit steps 5 through 9 of the following procedure.
 - An extra person is required to hold expanding side in position with pry bar while steps 5 through 8 are performed.
5. Insert pry bar (3) between Section floor (4) and expanding side (5). Apply pressure to hold expanding side (5) in position.
 6. At vertical gear rack positioning roller assembly (6), loosen bolts (7).
 7. Adjust pressure to pry bar (3) until there is 1/16- to 1/8-inch (1-2 cm) clearance between spur gear (8) and lower gear rack (9) as illustrated.
 8. Position roller assembly (6) firmly against expanding side (5) and secure bolts (7). Remove pry bar (3).
 9. Ensure clearance between spur gear (8) and lower gear rack (9) remains 1/16- to 1/8-inch (1-2 cm).

3-18. ALIGN EXPANDING SIDE GEAR MECHANISM (CONT)

NOTE

If only the roller bearing is being adjusted, omit steps 10 through 12 of the following procedure.

10. Loosen jam nut (10).
11. Turn adjusting bolt (11) until there is 1/16- to 1/8-inch (1-2 cm) clearance between upper spur gear (12) and upper gear rack (13). Turn bolt right to move gear in or left to move gear out.
12. Tighten jam nut (10).
13. Remove hydraulic jack.

CAUTION

Before retracting expanding side, ensure areas at both expanding side tracks are clear of obstructions. Failure to do so may result in equipment damage.

14. Retract expanding side (5) 4 to 6 inches (10-15 cm).
15. Position seal strip (2) and secure with screws (1).
16. Ensure rubber seal is firmly in track.
17. Extend expanding side (5).
18. Install removable floor section.

WARNING

Stay clear as folding floors are raised or lowered. Weight of floors may cause serious injury.

19. Lower folding floor and lock in down position (TM 5-3610-287-10, para 2-6).

ADJUSTING GEAR RACK TIMING

INITIAL SETUP

Tools

Master mechanic's tool kit (appendix B, section III, item 18)
Socket wrench set
Combination wrench set
Flat-tip screwdriver

3-18. ALIGN EXPANDING SIDE GEAR MECHANICAL (CONT)

Equipment Conditions

Section level and expanded (TM 5-3610-287-10, para 2-6)

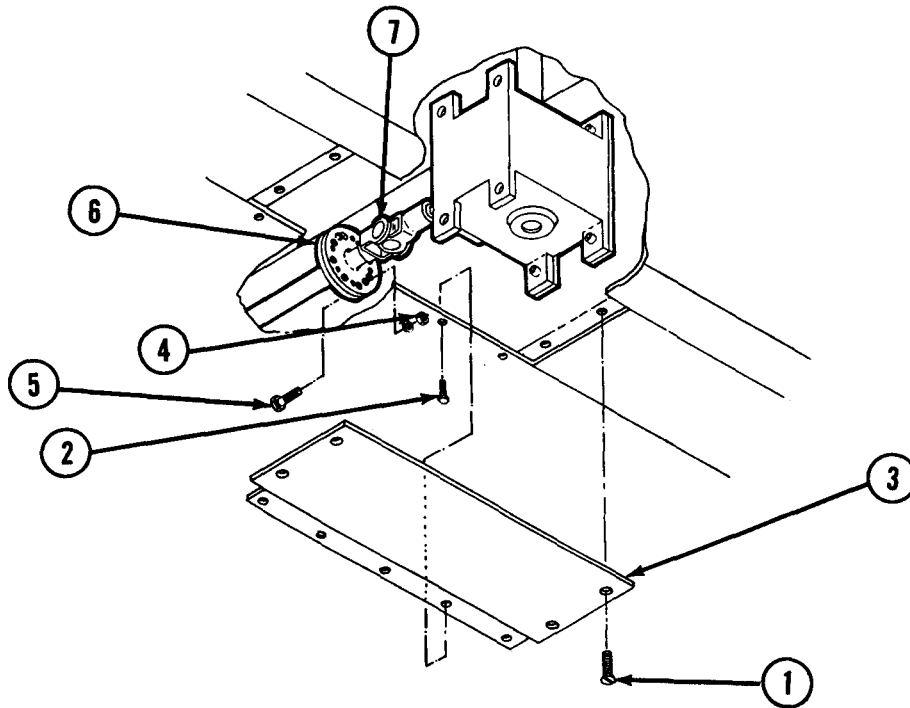
**WARNING**

Hold front cover plate firmly when removing attaching hardware. Plate may fall and cause injury.

NOTE

This procedure is performed only when both upper and lower gear racks on front or rear of expanding sides are out of time with opposite ends. Alignment must be made at front speed reducer.

1. Remove screws (1), hex bolts (2), and front cover plate (3).
2. Remove hex nuts (4), lockwashers, and hex bolts (5) on timing drive plates (6).
3. Count and record number of teeth between wiper seal and outer end of expanding side on lower gear racks.

3-18. ALIGN EXPANDING SIDE GEAR MECHANISM (CONT)

4. Rotate front speed reducer shaft (7) left or right until teeth counts on front and rear lower gear racks are equal. Then align two opposing holes in timing device plates (6).

CAUTION

Hex bolts must be installed off centerline of shaft assembly. Failure to correctly install these bolts will result in undue strain on connecting shafts.

5. Secure timing drive plates (6) with hex bolts (5), lockwashers, and hex nuts (4).
6. Test operate by expanding and retracting expanding sides.
7. Install front cover plate (3) with screws (1) and hex bolts (2).

3-19. REPAIR EXPANDING SIDE GEAR MECHANISM

Expanding side gear mechanism is repaired by replacing: Vertical gear rack positioning roller assembly.

VERTICAL GEAR RACK POSITIONING ROLLER ASSEMBLY

INITIAL SETUP

Tools

Master mechanic's tool kit (appendix B, section III, item 18)
Socket wrench set
Pry bar
Steel rule
Hydraulic jack (appendix B, section III, item 17)

Materials/Parts

Vertical gear rack positioning roller assembly, 54-0186

Equipment Conditions

Section level and expanded (TM 5-3610-287-10, para 2-6)

3-19. REPAIR EXPANDING SIDE MECHANISM (CONT)

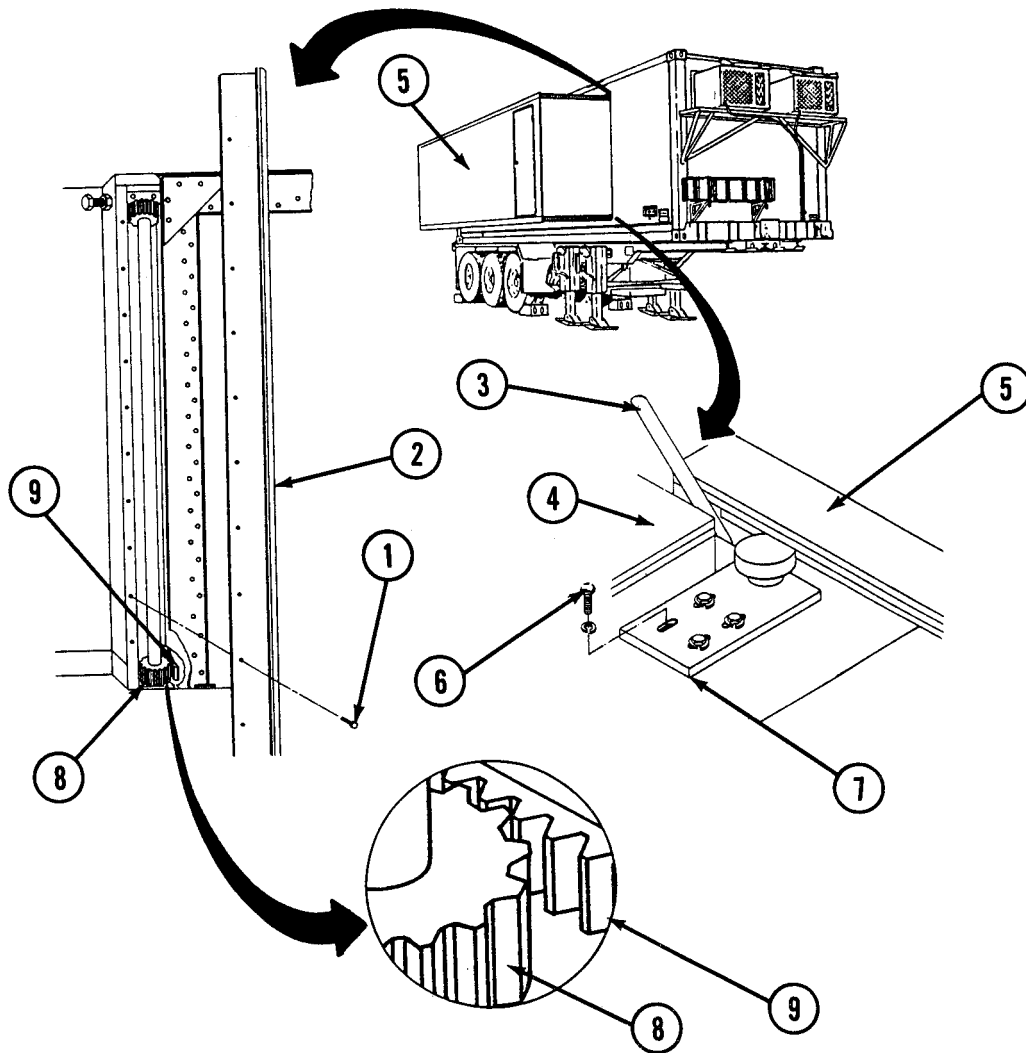

WARNING

Be sure expanding side is firmly blocked and keep hands away from gear track area while performing the following procedure. Serious injury to personnel and damage to equipment may result if gear track slips.

1. Place hydraulic jack under outside corner of expanding side.

WARNING

Stay clear as folding floors are raised or lowered. Weight of floors may cause serious injury.

2. Unlock and raise folding floor (TM 5-3610-287-10, para 2-7).

3-19. REPAIR EXPANDING SIDE GEAR MECHANISM (CONT)

3. Remove both removable floor sections.
4. Remove 10 screws (1) securing seal strip (2) to Section. Move seal strip (2) aside.

NOTE

A second person is required to hold expanding side in position with pry bar while the following steps are performed.

5. Insert pry bar (3) between Section floor (4) and expanding side (5). Apply pressure to hold expanding side (5) in position.
6. Remove bolts (6), lockwashers, and vertical gear rack positioning roller assembly (7).
7. Position new vertical gear rack positioning roller assembly (7). Install bolts (6) and lockwashers. Snug, but do not tighten.
8. Apply pressure to pry bar (3) until there is 1/16- to 1/8-inch (1-2 cm) clearance between spur gear (8) and teeth and lower gear rack (9) as illustrated.
9. Position roller assembly (7) firmly against expanding side (5) and secure bolts (6). Remove pry bar (3).
10. Ensure clearance between spur gear (8) and lower gear rack (9) remains 1/16- to 1/8-inch (1-2 cm).
11. Remove hydraulic jack.

CAUTION

Before retracting expanding side, ensure areas at both expanding side tracks are clear of obstructions. Failure to do so may result in equipment damage.

12. Retract expanding side (5) 4 to 6 inches (10-15 cm).
13. Position seal strip (2) and secure with screws (1).
14. Ensure rubber seal is firmly in track.
15. Extend expanding side (5).
16. Install removable floor section.

3-19. REPAIR EXPANDING SIDE GEAR MECHANISM (CONT)

WARNING

Stay clear as folding floors are raised or lowered. Weight of floors may cause serious injury.

17. Lower folding floor and lock in down position (TM 5-3610-287-10, para 2-6).

APPENDIX A

REFERENCES

A-1. SCOPE. This appendix lists all references used in conjunction with this manual.

A-2. FORMS

Recommended Changes to Publications and Blank Forms	DA Form 2028
Recommended Changes to Equipment Technical Publications	DA Form 2028-2
Hand Receipt/Annex Number	DA Form 2062
Equipment Inspection and Maintenance Worksheet	DA Form 2404
Report of Discrepancy	SF Form 364
Quality Deficiency Report	SF Form 368

A-3 . FIELD MANUALS

First Aid for Soldiers	FM 21-11
------------------------------	----------

A-4 . TECHNICAL MANUALS

Operator's, Organizational, Direct Support, and General Support Maintenance Manual for the Topographic Support System Chassis, Semitrailer	TM 5-2330-305-14
Operator's Maintenance Manual, Topographic Support System press Section printing Press	TM 5-3610-286-10
Organizational Maintenance Manual, Topographic Support System Press Section Printing Press	TM 5-3610-286-20
Operator's Manual for the Topographic Support System Press Section	TM 5-3610-287-10
Item (COEI), Basic Issue Items (B11), and Additional Authorization List (AAL) for Topographic Support System Press Section	TM 5-3610-287-10-HR

A-4. TECHNICAL MANUALS (CONT)

Organizational, Direct Support, and General Support
Maintenance Manual for the Topographic Support
System Press Section TM 5-3610-287-24

Organizational, Direct Support, and General
Support Maintenance Repair Parts and
Special Tools List for the Topographic
SUPPORT SYSTEM PRESS Section TM 5-3610-287-24P

Operator's, Organizational, Direct Support, and
General Support Maintenance Manual, Air
Conditioner, Horizontal, Compact, 18,000 BTU/HR
Cooling TM 5-4120-367-14

Painting Instructions for Field Use TM 43-0139

Administrative Storage of Equipment TM 740-90-1

A-5. MISCELLANEOUS PUBLICATIONS

Accounting for Lost, Damaged, and Destroyed
Property AR 735-11

Reporting of Item and Packaging Discrepancies AR 735-11-2

The Army Maintenance Management System
(TAMMS) DA PAM 738-750

Lubrication Order, Topographic Support System
Chassis, Semitrailer LO 5-2330-305-12

Lubrication Order, Topographic Support System Press
Section Printing Press LO 5-3610-286-12

Lubrication Order, Topographic Support
System Press Section LO 5-3610-287-12

APPENDIX B

MAINTENANCE ALLOCATION CHART

Section I. INTRODUCTION**B-1. GENERAL**

a. This section provides a general explanation of all maintenance and repair functions authorized at various maintenance categories.

b. The Maintenance Allocation Chart (MAC) in section II designates overall authority and responsibility for the performance of maintenance functions on the identified end item or component. The application of the maintenance functions to the end item or component will be consistent with the capacities and capabilities of the designated maintenance categories.

c. Section III lists the tools and test equipment (both special tools and common tool sets) required for each maintenance function as referenced from section II.

d. Section IV contains supplemental instructions and explanatory notes for a particular maintenance function.

B-2. MAINTENANCE FUNCTIONS. Maintenance functions will be limited to and defined as follows:

a. Inspect. To determine the serviceability of an item by comparing its physical, mechanical, and/or electrical characteristics with established standards through examination (e.g., by sight, sound, or feel).

b. Test. To verify serviceability by measuring the mechanical, pneumatic, hydraulic, or electrical characteristics of an item and comparing those characteristics with prescribed standards.

c. Service. Operations required periodically to keep an item in proper operating condition, i.e., to clean (includes decontaminate, when required), to preserve, to drain, to paint, or to replenish fuel, lubricants, chemical fluids, or gases.

d. Adjust. To maintain or regulate, within prescribed limits, by bringing into proper or exact position, or by setting the operating characteristics to specified parameters.

e. Align. To adjust specified variable elements of an item to bring about optimum or desired performance.

B-2. MAINTENANCE FUNCTIONS (CONT)

f. Calibrate. To determine and cause corrections to be made or to be adjusted on instruments or test, measuring, and diagnostic equipments used in precision measurement. Consists of comparisons of two instruments, one of which is a certified standard of known accuracy, to detect and adjust any discrepancy in the accuracy of the instrument being compared.

g. Remove/Install. To remove and install the same item when required to perform service or other maintenance functions. Install may be the act of emplacing, seating, or fixing into position a spare, repair part, or module (component or assembly) in a manner to allow the proper functioning of an equipment or system.

h. Replace. To remove an unserviceable item and install a serviceable counterpart in its place. "Replace" is authorized by the MAC and is shown as the third position code of the SMR code.

i. Repair. The application of maintenance services,¹ including fault location/troubleshooting,² removal/installation, and disassembly/assembly procedures,³ and maintenance actions⁴ to identify troubles and restore serviceability to an item by correcting specific damage, fault, malfunction, or failure in a part, subassembly, module (component or assembly), end item, or system.

j. Overhaul. That maintenance effort (service/action) prescribed to restore an item to a completely serviceable/operational condition as required by maintenance standards in appropriate technical publications (i.e, DMWR). Overhaul is normally the highest degree of maintenance performed by the Army. Overhaul does not normally return an item to like-new condition.

¹Services - inspect, test, service, adjust, align, calibrate, and/or replace.

²Fault locate/troubleshoot - the process of investigating and detecting the cause of equipment malfunctioning; the act of isolating a fault within a system or unit under test (UUT).

³Disassemble/assemble - encompasses the step-by-step taking apart (or breakdown) of a spare/functional group coded item to the level of its least componenty identified as maintenance significant (i.e., assigned an

⁴Actions - welding, grinding, riveting, straightening, facing, remachining, and/or resurfacing.

B-2. MAINTENANCE FUNCTIONS (CONT)

k. Rebuild. Consists of those services/actions necessary for the restoration of unserviceable equipment to a like-new condition in accordance with original manufacturing standards. Rebuild is the highest degree of materiel maintenance applied to Army equipment. The rebuild operation includes the act of returning to zero those age measurements (hours/miles , etc.) considered in classifying Army equipment/components.

B-3. EXPLANATION OF COLUMNS IN THE MAC, SECTION II

a. Column 1, Group Number. Column 1 lists functional group code numbers, the purpose of which is to identify maintenance significant components, assemblies, subassemblies, and modules with the next higher assembly. End item group number shall be "00."

b. Column 2, Component/Assembly. Column 2 contains the names of components, assemblies, subassemblies, and modules for which maintenance is authorized.

c. Column 3, Maintenance Function. Column 3 lists the functions to be performed on the item listed in column 2. (For a detailed explanation of these functions, see paragraph B-2.)

d. Column 4, Maintenance Category. Column 4 specifies, by the listing of a work time figure in the appropriate subcolumn(s), the category of maintenance authorized to perform the function listed in column 3. This figure represents the active time required to perform that maintenance function at the indicated category of maintenance. If the number or complexity of the tasks within the listed maintenance function vary at different maintenance categories, appropriate work time figures will be shown for each category. The work time figure represents the average time required to restore an item (assembly, subassembly, component, module, end item, or system) to a serviceable condition under typical field operating conditions. This time includes preparation time (including any necessary disassembly/assembly time), troubleshooting/fault location time, and quality assurance/quality control time in addition to the time required to perform the specific tasks identified for the maintenance functions authorized in the maintenance allocation chart. The symbol designations for the various maintenance categories are as follows:

- C Operator or crew
- O Organizational maintenance
- F Intermediate Direct Support maintenance
- H Intermediate General Support maintenance
- D Depot maintenance

e. Column 5, Tools and Equipment. Column 5 specifies, by code, those common tool sets (not individual tools) and special tools, TMDE, and support equipment required to perform the designated function.

B-3. EXPLANATION OF COLUMNS IN THE MAC, SECTION II (CONT)

f. Column 6, Remarks. This column shall, when applicable, contain a letter code, in alphabetic order, which shall be keyed to the remarks contained in section IV.

B-4. EXPLANATION OF COLUMNS IN TOOL AND TEST EQUIPMENT REQUIREMENTS, SECTION III

a. Column 1, Reference Code. The tool and test equipment reference code correlates with a code used in the MAC, section II, column 5.

b. Column 2, Maintenance Category. The lowest category of maintenance authorized to use the tool or test equipment.

c. Column 3, Nomenclature. Name or identification of the tool or test equipment.

d. Column 4, National Stock Number. The National stock number of the tool or test equipment.

e. Column 5, Tool Number. The manufacturer's part number.

B-5. EXPLANATION OF COLUMNS IN REMARKS, SECTION IV

a. Column 1, Reference Code. The code recorded in section II, column 6.

b. Column 2, Remarks. This column lists information pertinent to the maintenance function being performed as indicated in the MAC, section II.

Section II. MAINTENANCE ALLOCATION CHART

FOR

TOPOGRAPHIC SUPPORT SYSTEM PRESS SECTION

(1) GROUP NUMBER	(2) COMPONENT/ASSEMBLY	(3) MAINTENANCE FUNCTION	(4) MAINTENANCE CATEGORY					(5) TOOLS AND EQUIPMENT	(6) REMARKS
			C	O	F	H	D		
00	PRESS SECTION	Overhaul							
01	MODIFIED SECTION ASSEMBLY	Inspect		0.2					
	EXTERNAL EXHAUST FAN HOUSING ASSEMBLY	Inspect Replace Repair	0.1 1.0 1.5				9,10,11 9,10,11		
	REMOVABLE FLOOR SECTION CARRIER BRACKETS	Inspect Replace Repair	0.1 0.4 0.3				10,11 9,11		
	TOOL CADDY ASSEMBLY	Inspect Repair	0.1 0.3				11		
02	SAFETY AND SUPPORT ITEMS								
	STRAP AND BUCKLE ASSEMBLY	Inspect Replace	0.1 0.3				10,11		
	FIRST AID KIT	Inspect Replace	0.1 0.2				10,11		
	FIRE EXTINGUISHER	Inspect Replace	0.2 0.3				11		
	EMERGENCY LIGHT SET	Inspect Test Replace Repair	0.1 0.1 0.6 0.5				13 11 11		
	MIRROR AND SAFETY CHAIN	Inspect Service Replace	0.1 0.1 0.3				11		
	GROUND ROD ASSEMBLY	Inspect Service Replace Repair	0.1 0.1 0.5 0.1				1,4,5 1,4,5		

* Depot will determine worktime

Section II. MAINTENANCE ALLOCATION CHART

FOR

TOPOGRAPHIC SUPPORT SYSTEM PRESS SECTION (CONT)

(1) GROUP NUMBE	(2) COMPONENT/ASSEMBLY	(3) MAINTENANCE FUNCTION	(4) MAINTENANCE CATEGORY					(5) TOOLS AND EQUIPMENT	(6) REMARKS
			C	O	F	H	D		
03	LADDER ASSEMBLIES								
	BOARDING LADDER ASSEMBLY	Inspect Service Remove/Instal Repair	0.1 0.1 0.1					5, 7 10, 11	A
	FOLDING LADDER SUPPORT BRACKETS	Inspect Replace Repair	0.1	0.5 0.5				9, 11 10, 11	
04	AIR CONDITIONER/HEATER INSTALLATION								
	AIR CONDITIONER/ HEATER (TM 5-4120-367-14)	Replace			2.0			9, 18	
	AIR CONDITIONER/ HEATER MOUNTING BRACKET	Inspect Service Replace Repair	0.1	0.1 0.1 0.5		7.0		11 9, 15, 18, 19 11, 15, 16, 19	B
	VENTILATION DUCTS	Service	1.0					3, 4	
05	CABINETS								
	WALL STORAGE CABINET	Inspect Replace Repair	0.1	0.5 0.5				11 11	
	ROLLER STORAGE RACK	Inspect Replace Repair	0.1	0.5 0.5				11 9, 11	
	SPARE ROLLER RACK ASSEMBLIES	Replace		1.0				9, 11	
	SPARE ROLLER RACK COVER	Inspect Replace	0.1		0.7			9, 11	
	MODIFIED FIVE- DRAWER STORAGE CABINET	Inspect Replace Repair	0.1	1.0 0.5				11 11	

Section II. MAINTENANCE ALLOCATION CHART

FOR

TOPOGRAPHIC SUPPORT SYSTEM PRESS SECTION (CONT)

(1) GROUP NUMBER	(2) COMPONENT/ASSEMBLY	(3) MAINTENANCE FUNCTION	(4) MAINTENANCE CATEGORY					(5) TOOLS AND EQUIPMENT	(6) REMARKS
			C	O	F	H	D		
05 (cont)	JOGGING TABLE	Inspect	0.2						
	ASSEMBLY AND FEEDER	Replace		1.5				9, 11	
	PILE BOARD STORAGE RACK	Repair		1.0				11	
	GTO STORAGE CABINET	Inspect	0.2						
	ASSEMBLY	Service	0.1						
		Repair		0.5				10, 11	
06	SINK ASSEMBLY								
	FAUCET ASSEMBLY	Inspect	0.1						
		Replace		1.0				12	
		Repair		0.5				12	
	SINK TOP	Replace		1.5				9, 12	
	SINK CABINET	Inspect	0.1						
		Replace		2.0				9, 12	
07	PLUMBING								
	WATER PIPING	Inspect	0.2						
		Repair		0.5				11	
	MAIN PUMP	Inspect	0.1						
		Replace		1.0				11, 14	
	WATER TANK ASSEMBLY	Inspect	0.1						
		Repair		1.5				9, 12	
	WATER BOX ASSEMBLY	Inspect	0.1						
		Replace		1.5				9, 12, 19	
		Repair		0.2				10, 11	
08	ELECTRICAL SYSTEM								
	TELEPHONE INSTAL- LATION	Inspect	0.1						
		Test		0.2				13	
		Repair		0.5				11, 14	

Section II. MAINTENANCE ALLOCATION CHART

FOR

TOPOGRAPHIC SUPPORT SYSTEM PRESS SECTION (CONT)

(1) GROUP NUMBER	(2) COMPONENT/ASSEMBLY	(3) MAINTENANCE FUNCTION	(4) MAINTENANCE CATEGORY					(5) TOOLS AND EQUIPMENT	(6) REMARKS
			C	O	F	H	D		
08 (cont)	POWER ENTRY PANEL ASSEMBLY	Inspect	0.1					13 11, 14, 15, 16, 19	
		Test		0.3					
		Repair		1.0					
	POWER MONITOR ASSEMBLY	Inspect	0.1					13 11, 14 11, 14	
		Test		0.3					
		Replace Repair		1.0 1.5					
	LOAD CENTER	Inspect	0.1					13 11	
		Test		0.2					
		Repair		1.5					
	BLACKOUT LIGHT SYSTEM	Inspect	0.1					13 2, 4, 11, 14	C
Test			0.1						
Repair			0.2 0.5						
DOME LIGHT ASSEMBLY	Inspect	0.1					13 11, 14	C	
	Test		0.1						
	Replace Repair		0.5 0.2						
FLUORESCENT LIGHT	Inspect	0.1					13 4, 11, 14	D	
	Test		0.2						
	Repair		0.1 0.5						
ON/OFF SWITCH	Inspect	0.1					13 11, 14		
	Test		0.1						
	Replace		0.4						
WALL OUTLET	Inspect	0.1					13 11, 14		
	Test		0.1						
	Replace		0.4						

* Depot will determine worktime

Section II. MAINTENANCE ALLOCATION CHART

FOR

TOPOGRAPHIC SUPPORT SYSTEM PRESS SECTION (CONT)

(1) GROUP NUMBER	(2) COMPONENT/ASSEMBLY	(3) MAINTENANCE FUNCTION	(4) MAINTENANCE CATEGORY					(5) TOOLS AND EQUIPMENT	(6) REMARKS
			C	O	F	H	D		
08 (cont)	EXHAUST FAN ASSEMBLY	Inspect	0.1						
		Service	0.5					4	
		Test		0.2				13	
		Replace		1.0				11, 14	
		Repair		0.5				11, 14	
	WALL HEATER	Inspect	0.1						
		Service	0.5					4	
		Test		0.2				13	
		Replace		1.0				11, 14	
		Repair		0.7				11, 14	
	EXPANDING SIDE POWER CABLE	Inspect	0.2						
		Test		0.2				13	
Repair			1.0				11, 14		
POWER CABLE ASSEMBLY (GENERATOR)	Inspect	0.1							
	Test		0.3				13		
09	PRINTING PRESS (TM 5-3610-286-20)	Replace						*	
10	EXPANDABLE BODY BOX								
	SECTION BODY SKIN	Inspect	0.2						
		Repair		1.0	1.0			10, 11, 19	E
	INCLINOMETER ASSEMBLY	Inspect	0.2						
		Repair		0.8				9, 10, 11, 19	
	DOOR HINGE	Inspect	0.1						
		Service	0.1						
		Replace			1.5			18, 19	
	PERSONNEL/EQUIPMENT DOORS	Inspect	0.1						
		Service	0.3						
		Adjust		0.5				11	
		Replace			1.0			18, 19	
		Repair		0.3	1.0			11, 18	F
	BLACKOUT CURTAINS	Inspect	0.1						
		Repair	0.5						

* Depot will determine worktime

Section II. MAINTENANCE ALLOCATION CHART

FOR

TOPOGRAPHIC SUPPORT SYSTEM PRESS SECTION (CONT)

(1) GROUP NUMBER	(2) COMPONENT/ASSEMBLY	(3) MAINTENANCE FUNCTION	(4) MAINTENANCE CATEGORY					(5) TOOLS AND EQUIPMENT	(6) REMARKS
			C	O	F	H	D		
10 (cont)	WINCH ASSEMBLY	Inspect	0.1						
		Service	0.2						
		Replace		0.7				11	
		Repair		0.5				11	
	HANDWINCH	Repair		1.5				11	
	FOLDING FLOOR ASSEMBLY	Inspect	0.4						
		Service	0.3						
		Replace					*		
	REMOVABLE FLOOR SECTION	Inspect	0.1						
	EXPANDING SIDE ASSEMBLY	Inspect	0.1						
Service		0.5							
Replace				6.0			*	18	
EXPANDING SIDE GEAR MECHANISM	Inspect	0.1							
	Align			3.0					
	Replace			8.0			*	17, 18	
	Repair						*	17, 18	
11	TRAILER CHASSIS (TM 5-2330-305-14)	Replace					*		

* Depot will determine worktime

Section III. TOOL AND TEST EQUIPMENT REQUIREMENTS

FOR

TOPOGRAPHIC SUPPORT SYSTEM PRESS SECTION

(1) TOOL OR TEST EQUIPMENT REF CODE	(2) MAINTENANCE CATEGORY	(3) NOMENCLATURE	(4) NATIONAL/NATO STOCK NUMBER	(5) TOOL NUMBER
1	C	SLIDE HAMMER ASSEMBLY		P74-144 (45225)
2	C	SCREWDRIVER, CROSS- TIP, NO. 1	5120-00-764-8080	
3	C	SCREWDRIVER, CROSS- TIP, NO. 3	5120-00-764-8102	
4	C	SCREWDRIVER, FLAT- TIP, 1/4-INCH	5120-00-234-8910	
5	C	ADJUSTABLE WRENCH	5120-00-240-5328	
6	C	SLIP-JOINT PLIERS	5120-00-233-7396	
7	C	SOCKET WRENCH SET (13 ITEMS)	5120-00-081-2305	
8	C	HAMMER, 4-OZ.	5120-00-113-3516	
9	C, O, F	KNIFE, SCRAPING	5110-00-221-1538	
10	O	RIVET GUN	5120-00-756-5569	
11	O	LIGHT MACHINE REPAIR TOOL KIT	5180-00-596-1540	W43827
12	O	SHOP EQUIPMENT AUTOMOTIVE MAINTENANCE AND REPAIR, OM, COMMON NO. 1 LESS POWER	4910-00-754-0654	W32593

Section III. TOOL AND TEST EQUIPMENT REQUIREMENTS

FOR

TOPOGRAPHIC SUPPORT SYSTEM PRESS SECTION (CONT)

(1) TOOL OR TEST EQUIPMENT REF CODE	(2) MAINTENANCE CATEGORY	(3) NOMENCLATURE	(4) NATIONAL/NATO STOCK NUMBER	(5) TOOL NUMBER
13	O	MULTIMETER AN/PSN-45	6625-01-139-2512	M60449
14	O	CRIMPING TOOL/WIRE STRIPPER	5110-00-177-7287	
15	O, F	PLIERS, DIAGONAL CUTTING	5110-00-472-2418	
16	O, F	KNIFE	3615-01-099-0787	
17	F	HYDRAULIC JACK	5120-00-224-7330	
18	F	MASTER MECHANIC'S MAINTENANCE AND REPAIR TOOL KIT	5180-00-699-5273	W45060
19	O, F	SHOP EQUIPMENT AUTOMOTIVE MAINTENANCE AND REPAIR, ORG SUPPLEMENTAL NO. 1 LESS POWER		W32867

Section III. **TOOL AND TEST EQUIPMENT REQUIREMENTS**
FOR
TOPOGRAPHIC SUPPORT SYSTEM PRESS SECTION

(1) TOOL OR TEST EQUIPMENT REF CODE	(2) MAINTENANCE CATEGORY	NOMENCLATURE	(4) NATIONAL/NATO STOCK NUMBER	(5) TOOL NUMBER
1	C	SLIDE HAMMER ASSEMBLY		P74-144 (45225)
2	C	SCREWDRIVER, CROSS- TIP, NO. 1	5120-00-764-8080	
3	C	SCREWDRIVER, CROSS- TIP, NO. 3	5120-00-764-8102	
4	C	SCREWDRIVER, FLAT- TIP, 1/4-INCH	5120-00-234-8910	
5	C	ADJUSTABLE WRENCH	5120-00-240-5328	
6	C	SLIP-JOINT PLIERS	5120-00-233-7396	
7	C	SOCKET WRENCH SET (13 ITEMS)	5120-00-081-2305	
8	C	HAMMER, 4-OZ.	5120-00-113-3516	
9	C, O, F	KNIFE, SCRAPING	5120-00-221-1538	
10	O	RIVET GUN	5120-00-756-5569	PRG402
11	O	LIGHT MACHINE REPAIR TOOL KIT	5180-00-596-1540	W43827
12	O	SHOP EQUIPMENT AUTOMOTIVE MAINTENANCE AND REPAIR, OM, COMMON NO. 1 LESS POWER	4910-00-754-0654	W32593

Section III. **TOOL AND TEST EQUIPMENT REQUIREMENTS**

FOR

TOPOGRAPHIC SUPPORT SYSTEM PRESS PRESS SECTION (CONT)

(1) TOOL OR TEST EQUIPMENT REF CODE	(2) MAINTENANCE CATEGORY	(3) NOMENCLATURE	(4) NATIONAL/NATO STOCK NUMBER	(5) TOOL NUMBER
13	O	MULTIMETER AN/PSN-45	6625-01-139-2512	M60449
14	O	CRIMPING TOOL/WIRE STRIPPER	5110-00-177-7287	
15	O, F	PLIERS, DIAGONAL CUTTING	5110-00-472-2418	
16	O, F	KNIFE	3615-01-099-0787	
17	F	HYDRAULIC JACK	5120-00-224-7330	
18	F	MASTER MECHANIC'S MAINTENANCE AND REPAIR TOOL KIT	5180-00-699-5273	W45060
19	O, F	SHOP EQUIPMENT AUTOMOTIVE MAINTENANCE AND REPAIR, ORG SUPPLEMENTAL NO. 1 LESS POWER		W32867

Section IV. REMARKS

Reference Code	Remarks
A	Crew remove/install consists of removing and installing ladder only. Mounting points on ladder may require adjustment to install.
B	Organizational repair consists of tightening connections and replacing bezel gaskets and drain tubes. DS/GS repair consists of welding.
C	Crew maintenance consists of replacing lamp and/or lens only.
D	Crew maintenance consists of replacing fluorescent lamp only.
E	Organizational maintenance performs temporary repairs to Section body skin. DS/GS maintenance performs permanent repair to Section body skin.
F	Organizational maintenance consists of replacing handles and security bolt only.

APPENDIX C

EXPENDABLE/DURABLE SUPPLIES AND MATERIALS LIST

Section I. INTRODUCTION

C-1. SCOPE. This appendix lists expendable/durable supplies and materials you will need to operate and maintain the TSS Press Section. This listing is for informational purposes only and is not authority to requisition listed items. These items are authorized to you by CTA 50-970, Expendable/Durable Items (Except Medical, Class V, Repair Parts and Heraldic Items).

C-2. EXPLANATION OF COLUMNS

a. Column (1) - Item Number. This number is assigned to the entry in the listing and is referenced in the narrative instructions to identify the material (e.g., "Use cleaning compound, item 5, appendix C").

b. Column (2) - Level. This column identifies the lowest level of maintenance that requires the listed item.

- O - Organizational Maintenance
- F - Direct Support Maintenance
- H - General Support Maintenance

c. Column (3) - National Stock Number. This is the National stock number assigned to the item; use it to request or requisition the item.

d. Column (4) - Description. Indicates the Federal item name and, if required, a description to identify the item. The last line for each item indicates the Federal Supply Code for Manufacturer (FSCM) in parentheses followed by the part number.

e. Column (5) - Unit of Measure (U/M). Indicates the measure used in performing the actual maintenance function. This measure is expressed by a two-character alphabetical abbreviation (e.g., ea, in., pr). If the unit of measure differs from the unit of issue, requisition the lowest unit of issue that will satisfy your requirements.

Section II. EXPENDABLE/DURABLE SUPPLIES AND MATERIALS LIST

(1) ITEM NUMBER	(2) LEVEL	(3) NATIONAL STOCK NUMBER	(4) DESCRIPTION	(5) U/M
1	O	8040-00-152-0063	ADHESIVE, RUBBER (MMM-A-1617, Type 3)	CA
2	O	6510-01-060-1639	ADHESIVE TAPE, SURGICAL	PG
3	O	6515-00-754-0426	BLADE, SURGICAL	PG
4	O		BRUSH, WIRE (55719) AC58C	EA
5	O	7920-00-291-5815	BRUSH, WIRE, SCRATCH	EA
6	O	8040-00-901-4259	CEMENT, RUBBER	CN
7	O	8040-00-865-8991	COMPOUND, SILICONE	EA
8	O	7510-00-949-5055	ERASER, RUBBER, 188 IN.	DZ
9	O	8415-00-248-3228	GLOVES, DISPOSABLE	RL
10	O	9150-00-190-0905	GREASE, AUTOMOTIVE AND ARTILLERY (MIL-G-10924)	CN
11	O	8520-00-965-2109	HAND CLEANER	LB
12	O		INSULATION, SPRAY FOAM (30890) PV3	CN
13	O	7510-00-285-5866	LEAD PENCIL, GRAPHITE	DZ
14	O	7520-00-295-6170	LEAD REPOINTER, PENCIL	EA
15	F, H	9150-00-153-0207	LUBRICATING OIL, ENGINE (81349) MIL-L-21260	CN
16	O	9150-00-188-9858	LUBRICATING OIL, ENGINE (MIL-L-2104 GR30)	CN
17	O	2825-01-190-5961	OIL, LUBRICATING, SPRAY (MIL-M-7866, TYPE G)	CN

Section II. EXPENDABLE/DURABLE SUPPLIES AND MATERIALS LIST (CONT)

(1) ITEM NUMBER	(2) LEVEL	(3) NATIONAL STOCK NUMBER	(4) DESCRIPTION	(5) U/M
18	O, F, H	8010-01-141-2419	PAINT, BLACK (81349) MIL-C-46168, TYPE 2	KT
19	O, F, H	8010-01-160-6744	PAINT, BROWN, NO. 383 (81349) MIL-C-46168, TYPE 2	KT
20	O, F, H	8010-01-160-6741	PAINT, GREEN, NO. 383 (81349) MIL-C-46168, TYPE 2	KT
20A	O, F, H		PAINT, LIGHT GREEN (06542) FS-595/24533	GL
21	O	7510-00-240-1526	PENCIL, BLACK, GLAZED SURFACE	DZ
22	O	6505-00-914-3593	POVIDONE-IODINE	BX
22A	O, F, H		PRIMER (54636) E-2A-28	GL
23	O, F, H	8010-01-193-0516	PRIMER, EPOXY	KT
24	O	7920-00-148-9666	RAG, WIPING	BE
25	O	7920-00-240-2555	SPONGE, CELLULOSE	EA
26	O, F, H	4940-00-803-6444	SPRAY KIT, SELF-PRESSURIZED	KT
27	O	5640-00-103-2254	TAPE, DUCT	EA
28	O	1430-00-854-4486	TAPE, ELECTRICAL	EA
29	O	7510-01-050-6048	TAPE, MASKING	EA
30	O	8315-00-868-0767	TAPE, PTFE (MIL-T-27730A	EA
31	O, F, H	8010-01-200-2637	THINNER	GL

Section II. **EXPENDABLE/DURABLE SUPPLIES AND MATERIAL LIST (CONT)**

(1) ITEM NUMBER	(2) LEVEL	(3) NATIONAL STOCK NUMBER	(4) DESCRIPTION	(5) U/M
32	O, F, H	8010-01-181-8080	THINNER, ALIPHATIC (81349) MIL-T-81772	GL
33	O	8010-01-105-9036	THINNER, RUBBER CEMENT	PT
34	O	7920-00-823-9772	TOWEL, PAPER	MX

INDEX

Subject	Paragraph, Table, Appendix
A	
Air Conditioner/Heater Mounting Bracket, Repair	2-26
Air Conditioner/Heater Mounting Bracket, Replace	3-12
Air Conditioner/Heater Support Brackets, PMCS	T 2-2
Air Conditioner/Heaters, Replace	3-11
B	
Blackout Light System, Repair	2-52
Boarding Ladder Assembly, Repair	2-23
C	
Checking Unpacked Equipment	2-6, 3-6
Common Tools and Equipment	2-1, 3-1
D	
Destruction of Army Materiel to Prevent Enemy Use	1-3
Direct Support and General Support Maintenance Procedures	3-10
Direct Support and General Support Preventive Maintenance Checks and Services (PMCS)	3-8
Direct Support and General Support Troubleshooting	3-9, T 3-1
Dome Light Assembly, Replace	2-53
Door Hinges, Replace	3-14
E	
Emergency Light Set, Repair	2-21
Emergency Light Set, Replace	2-20
Emergency Light Set Simplified Schematic, Figure 2-1	2-10
Equipment Characteristics, Capabilities, and Features	1-7
Exhaust Fan Assembly, Repair	2-58
Exhaust Fan Assembly, Replace	2-57
Expanding Side Assembly, Repair	3-17
Expanding Side Gear Mechanism, Align	3-18
Expanding Side Gear Mechanism, Repair	3-19
Expanding Side Power Cable, Repair	2-61
Expendable/Durable Supplies and Materials List	C
External Exhaust Fan Housing Assembly, Repair	2-13
External Exhaust Fan Housing Assembly, Replace	2-12

INDEX (CONT)

Subject	Paragraph, Table, Appendix
F	
Faucet Assembly, Repair	2-39
Faucet Assembly, Replace	2-38
Fire Extinguisher, Replace	2-19
First Aid Kit, Replace	2-18
Fluorescent Light, Repair	2-54
Folding Ladder Support Brackets, Repair	2-25
Folding Ladder Support Brackets, Replace	2-24
G	
GTO Storage Cabinet Assembly, Repair	2-37
H	
Handwinch, Repair	2-68
I	
Inclinometer Assembly, Repair	2-63
J	
Jogging Table Assembly and Feeder Pile Board Storage Rack, Repair	2-36
Jogging Table Assembly and Feeder Pile Board Storage Rack , Replace	2-35
L	
Load Center, Repair	2-51
Location and Description of Major Components	1-8
M	
Main Pump, Replace	2-43
Maintenance Allocation Chart	B
Maintenance Forms and Records	1-2
Mirror and Safety Chain, Replace	2-22
Modified Five-Drawer Storage Cabinet, Repair	2-34
Modified Five-Drawer Storage Cabinet, Replace	2-33
Modified Section Assembly, PMCS	T 2-2

INDEX (CONT)

Subject	Paragraph, Table, Appendix
O	
Official Nomenclature List	1-5
ON/OFF Switch, Replace	2-55
Operational Check	2-8
Organizational Maintenance Procedures	2-11
Organizational Preventive Maintenance Checks and Services (PMCS)	2-9, T 2-2
Organizational Troubleshooting	2-10, T 2-3
P	
Personnel/Equipment Door, Adjust	2-64
Personnel/Equipment Door, Repair	2-65
Personnel/Equipment Door, Repair	3-16
Personnel/Equipment Door, Replace	3-15
Power Entry-Panel Assembly, Repair	2-48
Power Monitor Assembly, Repair	2-50
Power Monitor Assembly, Replace	2-49
Power Monitor Assembly Simplified Schematic, Figure 2-2	2-10
Preliminary Service	2-7, 3-7
Preparation for Storage or Shipment	1-4
R	
References	A
Removable Floor Section Carrier Brackets, Repair	2-15
Removable Floor Section Carrier Brackets, Replace	2-14
Repair Parts	2-3, 3-3
Reporting Equipment Improvement Recommendations (EIRs)	1-4
Roller Storage Rack, Repair	2-30
Roller Storage Rack, Replace	2-29
S	
Scope	1-1
Section Body Skin (Permanent), Repair	3-13
Section Body Skin (Temporary), Repair	2-62
Service Upon Receipt of Material	2-5, 3-5
	T 2-1
Sink Cabinet, Replace	2-41
Sink Top, Replace	2-40
Site Requirements	2-4, 3-4
Spare Roller Rack Assembly, Replace	2-31
Spare Roller Rack Cover, Replace	2-32

INDEX (CONT)

Subject	Paragraph, Table, Appendix
Special Tools, TMDE, and Support Equipment	2-2, 3-2
Strap and Buckle Assembly, Replace	2-17
Symptom Index, Troubleshooting	2-10
T	
Technical Principles of Operation	
Electrical System	1-9
Expanding Side System	1-9
Plumbing System	1-9
Ventilation and Exhaust System	1-9
Telephone Installation, Repair	2-47
Tool Caddy Assembly, Repair	2-16
W	
Wall Heater, Repair	2-60
Wall Heater, Replace	2-59
Wall Outlet, Replace	2-56
Wall Storage Cabinet, Repair	2-28
Wall Storage Cabinet, Replace	2-27
Water Box Assembly, Repair	2-46
Water Box Assembly, Replace	2-45
Water Piping, Repair	2-42
Water Tank Assembly, Repair	2-44
Winch Assembly, Repair	2-67
Winch Assembly, Replace	2-66

By Order of the Secretary of the Army:

Official:

R. L. DILWORTH
Brigadier General, United States Army
The Adjutant General

JOHN A. WICKHAM, JR.
General, United States Army
Chief of Staff

DISTRIBUTION :

To be distributed in accordance with DA Form 12-25A, Organizational, Direct Support and General Support Maintenance requirements for Paper Conditioning Section, Topographic Support System, Model ADC-TSS-15.



THEN... JOT DOWN THE DOPE ABOUT IT ON THIS FORM, CAREFULLY TEAR IT OUT, FOLD IT AND DROP IT IN THE MAIL!

SOMETHING WRONG WITH THIS PUBLICATION?

FROM: (PRINT YOUR UNIT'S COMPLETE ADDRESS)
PFC JOHN DOE
COA, 3d ENGINEER BN
FT. LEONARDWOOD, MO 63108
 DATE SENT

PUBLICATION NUMBER: **TM 5-3610-287-24**
 PUBLICATION DATE: **13 June 1986**
 PUBLICATION TITLE: **Topographic Support System Press Section Model No. TEAD-TSS-21 NSN 3610-01-105-1744**

BE EXACT... PIN-POINT WHERE IT IS

PAGE NO.	PARA-GRAPH	FIGURE NO.	TABLE NO.
6	2-1 a		
B1		4-3	
125	line 20		

IN THIS SPACE TELL WHAT IS WRONG AND WHAT SHOULD BE DONE ABOUT IT:

In line 6 of paragraph 2-1a the manual states the engine has 6 Cylinders. The engine on my set only has 4 Cylinders. Change the manual to show 4 Cylinders.

Callout 16 on figure 4-3 is pointing at a bolt. In key to figure 4-3, item 16 is called a shim - Please correct one or the other.

I ordered a gasket, item 19 on figure B-16 by NSN 2 910-05-762-3001. I got a gasket but it doesn't fit. Supply says I got what I ordered, so the NSN is wrong. Please give me a good NSN

PRINTED NAME, GRADE OR TITLE, AND TELEPHONE NUMBER
JOHN DOE, PFC (268) 317-7111

SIGN HERE: **JOHN DOE**

TEAR ALONG PERFORATED LINE

FILL IN YOUR
UNIT'S ADDRESS

FOLD BACK

DEPARTMENT OF THE ARMY

OFFICIAL BUSINESS
PENALTY FOR PRIVATE USE \$300

POSTAGE AND FEES PAID
DEPARTMENT OF THE ARMY
DOD 314



COMMANDER
U S ARMY TROOP SUPPORT COMMAND
ATTN: AMSTR-MCTS
4300 GOODFELLOW BOULEVARD
ST. LOUIS, MO 63120-1798

TEAR ALONG PERFORATED LINE

RECOMMENDED CHANGES TO EQUIPMENT TECHNICAL PUBLICATIONS



THEN... JOT DOWN THE DOPE ABOUT IT ON THIS FORM. CAREFULLY TEAR IT OUT, FOLD IT AND DROP IT IN THE MAIL!

SOMETHING WRONG WITH THIS PUBLICATION?

FROM: (PRINT YOUR UNIT'S COMPLETE ADDRESS)

DATE SENT

PUBLICATION NUMBER

TM 5-3610-287-24

PUBLICATION DATE

13 June 1986

PUBLICATION TITLE Topographic Support System Press Section Model No.

TEAD-TSS-21 NSN 3610-01-105-1744

BE EXACT... PIN-POINT WHERE IT IS

PAGE NO

PARA-GRAPH

FIGURE NO

TABLE NO

IN THIS SPACE TELL WHAT IS WRONG AND WHAT SHOULD BE DONE ABOUT IT:

TEAR ALONG PERFORATED LINE

PRINTED NAME, GRADE OR TITLE, AND TELEPHONE NUMBER

SIGN HERE:

DA FORM 2028-2
1 JUL 79

PREVIOUS EDITIONS ARE OBSOLETE.
DRSTS-M Overprint 2, 1 Nov 80.

P.S.--IF YOUR OUTFIT WANTS TO KNOW ABOUT YOUR RECOMMENDATION MAKE A CARBON COPY OF THIS AND GIVE IT TO YOUR HEADQUARTERS.

FILL IN YOUR
UNIT'S ADDRESS

FOLD BACK

DEPARTMENT OF THE ARMY

OFFICIAL BUSINESS
PENALTY FOR PRIVATE USE \$300

POSTAGE AND FEES PAID
DEPARTMENT OF THE ARMY
DOD 314



TEAR ALONG PERFORATED LINE

COMMANDER
U S ARMY TROOP SUPPORT COMMAND
ATTN: AMSTR-MCTS
4300 GOODFELLOW BOULEVARD
ST. LOUIS, MO 63120-1798

RECOMMENDED CHANGES TO EQUIPMENT TECHNICAL PUBLICATIONS



THEN... JOT DOWN THE DOPE ABOUT IT ON THIS FORM. CAREFULLY TEAR IT OUT. FOLD IT AND DROP IT IN THE MAIL!

SOMETHING WRONG WITH THIS PUBLICATION?

FROM: (PRINT YOUR UNIT'S COMPLETE ADDRESS)

DATE SENT

PUBLICATION NUMBER

TM 5-3610-287-24

PUBLICATION DATE

13 June 1986

PUBLICATION TITLE Topographic Support System Press Section Model No.

TEAD-TSS-21 NSN 3610-01-105-1744

BE EXACT... PIN-POINT WHERE IT IS

PAGE NO.	PARA-GRAPH	FIGURE NO.	TABLE NO.
----------	------------	------------	-----------

IN THIS SPACE TELL WHAT IS WRONG AND WHAT SHOULD BE DONE ABOUT IT:

TEAR ALONG PERFORATED LINE

PRINTED NAME, GRADE OR TITLE, AND TELEPHONE NUMBER

SIGN HERE:

DA FORM 2028-2
1 JUL 79

PREVIOUS EDITIONS ARE OBSOLETE.
DRSTS-M Overprint 2, 1 Nov 80.

P.S.--IF YOUR OUTFIT WANTS TO KNOW ABOUT YOUR RECOMMENDATION MAKE A CARBON COPY OF THIS AND GIVE IT TO YOUR HEADQUARTERS.

FILL IN YOUR
UNIT'S ADDRESS

FOLD BACK

DEPARTMENT OF THE ARMY

OFFICIAL BUSINESS
PENALTY FOR PRIVATE USE \$300

POSTAGE AND FEES PAID
DEPARTMENT OF THE ARMY
DOD 314



TEAR ALONG PERFORATED LINE

COMMANDER
U S ARMY TROOP SUPPORT COMMAND
ATTN: AMSTR-MCTS
4300 GOODFELLOW BOULEVARD
ST. LOUIS, MO 63120-1798

RECOMMENDED CHANGES TO EQUIPMENT TECHNICAL PUBLICATIONS



THEN... JOT DOWN THE DOPE ABOUT IT ON THIS FORM. CAREFULLY TEAR IT OUT. FOLD IT AND DROP IT IN THE MAIL!

SOMETHING WRONG WITH THIS PUBLICATION?

FROM: (PRINT YOUR UNIT'S COMPLETE ADDRESS)

DATE SENT

PUBLICATION NUMBER

TM 5-3610-287-24

PUBLICATION DATE

13 June 1986

PUBLICATION TITLE Topographic Support System Press Section Model No. TEAD-TSS-21 NSN 3610-01-105-1744

BE EXACT... PIN-POINT WHERE IT IS

PAGE NO.	PARA-GRAPH	FIGURE NO.	TABLE NO.
----------	------------	------------	-----------

IN THIS SPACE TELL WHAT IS WRONG AND WHAT SHOULD BE DONE ABOUT IT:

TEAR ALONG PERFORATED LINE

PRINTED NAME, GRADE OR TITLE, AND TELEPHONE NUMBER

SIGN HERE:

DA FORM 2028-2
1 JUL 79

PREVIOUS EDITIONS ARE OBSOLETE.
DRSTS-M Overprint 2, 1 Nov 80.

P.S.--IF YOUR OUTFIT WANTS TO KNOW ABOUT YOUR RECOMMENDATION MAKE A CARBON COPY OF THIS AND GIVE IT TO YOUR HEADQUARTERS.

FILL IN YOUR
UNIT'S ADDRESS

FOLD BACK

DEPARTMENT OF THE ARMY

OFFICIAL BUSINESS
PENALTY FOR PRIVATE USE \$300

POSTAGE AND FEES PAID
DEPARTMENT OF THE ARMY
DOD 314



TEAR ALONG PERFORATED LINE

COMMANDER
U S ARMY TROOP SUPPORT COMMAND
ATTN: AMSTR-MCTS
4300 GOODFELLOW BOULEVARD
ST. LOUIS, MO 63120-1798

